



N² PRO / N² PRO-1234

REFRIGERANT

RECOVERY & RECHARGING

SYSTEM

OPERATORS MANUAL



TEN Automotive Equipment Limited

www.ten-automotive.co.uk



1: PREFACE

IMPORTANT: It is mandatory in the UK that the Operator of this Equipment is qualified in accordance with EC802-2006.

Please read this Operators Manual carefully and adhere to the Safety Precautions at ALL times. Mis-handling of Refrigerants and improper use of the Equipment & Accessories may cause serious injury or harm to the Operator. Damage to the Equipment and Vehicle A/C System may also occur.

The Model **N² PRO** should be used only with **R134A** Vehicle A/C Refrigerant Systems.

The Model **N² PRO-1234** should be used only with **R1234YF** Vehicle A/C Refrigerant systems.

Recycled Refrigerant (R134A / R1234YF) meets the required SAE standard. All Interfaces, Software design and Operation conform to EC802-2006 (MACS) Directive.



2: INDEX LISTING:

1.	PREFACE	1
2.	INDEX LISTING	2
3.	SAFETY PRECAUTIONS	3
4.	WARRANTY	4
5.	GLOSSARY OF TERMS	5
6.	CONTROL PANEL	5
7.	SYSTEM INITIAL SETUP	6
	7.1 Adding refrigerant to the work tank (first time)	6
	7.2 Printer set-up & operation (optional)	8
8.	OPERATION	11
	8.1 Recover refrigerant and oil drain	11
	8.2 Vacuum A/C system and inject new oil	13
	8.3 Recharge A/C system	14
	8.4 Hose recovery and system self cleaning	16
	8.5 Adding refrigerant to work tank	17
	8.6 Fully automatic operation	18
9.	ROUTINE MAINTENANCE	25
	9.1 Checking the capacity of the filter-drier	25
	9.2 Changing the filter-drier	26
	9.3 Checking the vacuum pump oil usage	28
	9.4 Replacing vacuum pump oil	29
10.	SPECIFICATIONS	32
11.	SPARE PARTS LIST	33
12.	CONTACT INFORMATION	33

3: SAFETY PRECAUTIONS

WARNING !! When handling Refrigerant, avoid skin contact; the low boiling temperature of refrigerant (-30°C) can cause freezing. Contact with refrigerant may cause frostbite, blindness and other serious personal injury.

IMPORTANT !! At all times it is recommended to wear suitable personal protective equipment PPE (Overalls, Safety Glasses/goggles and Gloves).

We recommend that this equipment is used by trained personnel only, who understand the basics of cooling systems, refrigerants and possible damage that pressurized equipment may cause. It is mandatory in the UK that the Operator is qualified in accordance with EC802-2006.

Carefully read the instructions contained in this manual and strictly adhere to the procedures described. This is paramount to Operator safety.

The equipment must always be used under the Operator's control.

Do not operate the unit with any refrigerant other than the one it has been designed for. (i.e. R134A or R1234YF).

Before each new vehicle connection, ensure that the LP & HP hoses have been previously evacuated and that zero pressure is shown on both gauges.

Avoid breathing refrigerant vapours. Only operate the unit in well ventilated areas, do not use while working in a vehicle inspection pit.

Do not operate near open flames and hot surfaces. High temperatures cause refrigerant to decompose, releasing hazardous toxic and caustic substances.

Always connected the unit to a 3 pin, protected and suitably earthed, mains 240vAC supply. Use of trailing sockets and extension leads are not recommended.

Before connecting and disconnecting the unit, ensure that any programmed operation cycle has been completed and that all valves are closed to avoid release of refrigerant to the atmosphere.

Never fill any tank, internal or external, with liquid refrigerant to more than 75% of maximum capacity.

Avoid spillage and dripping. Clean and mop up excess fluids.

IT IS ILLEGAL to charge a system with refrigerant, to check for leaks. Always use (Oxygen Free) Nitrogen for this purpose during the appropriate programmed operation cycle.

[Back to Index](#)

4: WARRANTY

CERTIFICATE OF WARRANTY

TEN Automotive Equipment Limited hereby declare to warrant the N² PRO / N² PRO-1234 product to be free from defects in material and manufacture for a period of 12 months from the date of purchase. During this period such defective components will be replaced without charges for “Callout” or “Labour” with the exception of instances referred to as Disclaimers and Exclusions or the unit is purchased and/or operated outside the United Kingdom.

DISCLAIMER AND EXCLUSIONS:

Charges for Callout, Labour, Calibration and, where applicable, replacement components or materials will be levied, at the prevailing rates, whereby:-

- 1: The defect or condition of the equipment is a product of neglect, improper use, lack of routine operator maintenance, vandalism, accident, fire, flood or Act of God.
- 2: Consumable items such as Printer Rolls, Cables, External Hoses and Quick Coupler Connectors, Oil/Drain Bowls and Drier/Filters are replaced.
- 3: Attempted repairs or adjustments by any person or Company not authorized or recognized by TEN Automotive Equipment Limited
- 4: If the authorized representative of TEN Automotive Equipment Limited has been refused, or is unable to access the equipment between the hours of 09:00 hrs to 17:30 hrs, Monday to Friday inclusive. In order to follow up a “Request for Service” under the Warranty Agreement.
- 5: If the Equipment has not been serviced or calibrated by an Authorized Representative of TEN Automotive Equipment Limited at a prearranged interval necessary to comply with an EU Directive or any other Approval Body mandatory requirement.
- 6: If TEN Automotive Equipment Limited is not afforded the opportunity to diagnose or rectify the fault or condition through simple diagnostic routines or instruction, by telephone, to the operator or owner of the equipment.

5: GLOSSARY OF TERMS

- SYSTEM -** N² PRO or N² PRO -1234 refrigerant recovery, recycling and recharging equipment.
- SOURCE TANK -** A refillable tank with new refrigerant used for topping up the internal Work Tank.
- ELECTRONIC SCALES -** Measures the weight of the Work Tank refrigerant.
- WORK TANK -** Refillable refrigerant internal storage tank inside the system. It is used to store refrigerant during recovery, and to recycle recovered refrigerant to SAE standard. The tank has three outlets, gas outlet, liquid outlet and air discharge outlet.

6: CONTROL PANEL

Note: Some models have the Printer mounted on the top of the cabinet.

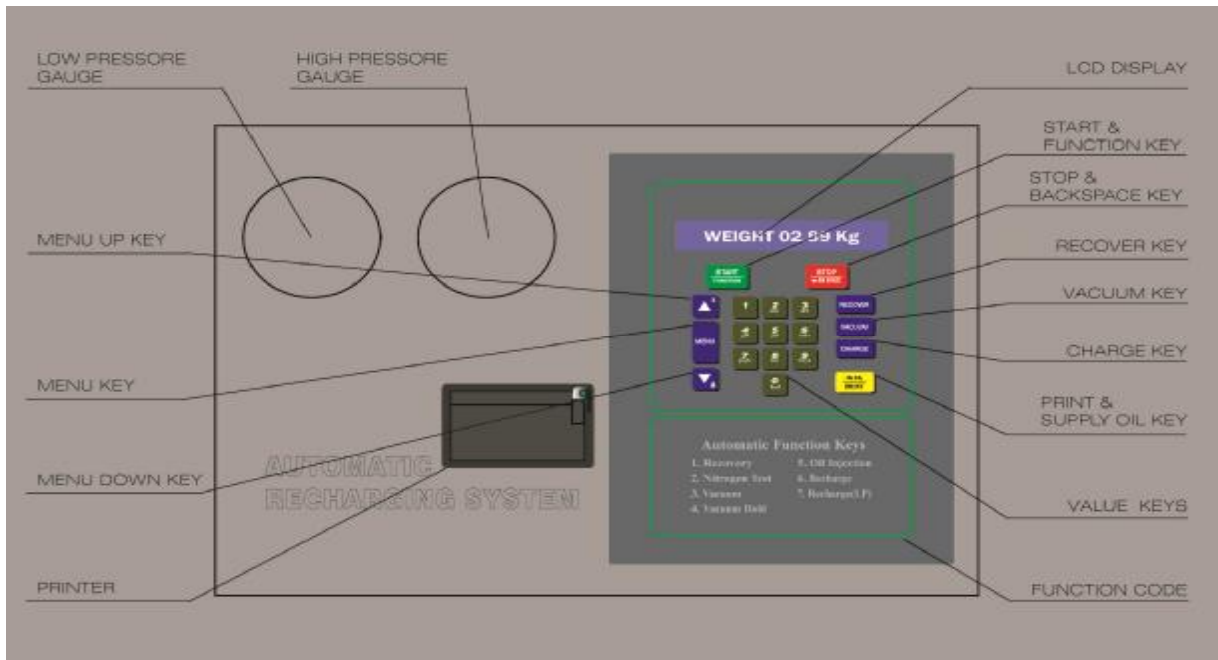

[Back to Index](#)



7: SYSTEM INITIAL SETUP



Before using the System for the first time the system initial setup is must be completed. The main purpose of the initial setup is:

- 1) To ensure Vacuum Pump oil level is correct.
- 2) To remove Nitrogen in the Work Tank and the system.
- 3) To prime Work Tank with fresh refrigerant.
- 4) Printer Set-up and Operation (Optional)

[Back to Index](#)

7.1 Adding Refrigerant to Work Tank (first time)

STEP	OPERATION	OPERATING INSTRUCTION	SCREEN DISPLAY
1		Turn the power switch on. Ensure Vacuum pump oil level is sufficient. Oil should be at the indicated level of sight glass on Vacuum Pump.	CLEAR
2		Press START key to begin the initialization process The screen will flash: PLEASE WAIT.	PLEASE WAIT
3	WAIT	If used for the first time the system will automatically remove Nitrogen in the Work Tank and internal system. This will take about 4 minutes and the system will finish the initialization process automatically.	PLEASE WAIT
4	WAIT	After the initialization process, the system will automatically display: WEIGHT xx.xx (or System Standby mode). Now new refrigerant needs to be added to the Work Tank.	WEIGHT 00.00 kg







<p>5.</p>		<ol style="list-style-type: none"> 1. Connect the low pressure male adaptor to the refrigerant source tank. 2. Connect the low pressure “quick coupler” to the male adaptor. 3. Open source tank valve and Blue “quick coupler” valve. 4. Press the Recover Key 	<div style="border: 1px solid black; padding: 5px; text-align: center;"> <p>RECOVER 10.00 kg</p> </div> <p>Note: 10.00kg is the amount of refrigerant that the Work Tank can contain.</p> <p>If male adaptor is not available use a suitable alternative coupling to connect low pressure hose to source tank.</p>
<p>6</p>		<p>Press the START key to begin the refrigerant filling process.</p> <p>Please ensure that Source tank and blue quick coupler valves are open.</p>	<div style="border: 1px solid black; padding: 5px; text-align: center;"> <p>RECOVER 00.00 kg</p> </div>
<p>7</p>	<p> WAIT</p>	<p>When adding refrigerant to Work Tank the displayed amount will increase.</p> <p>Note: Turn source tank upside down to increase flow, if required.</p>	<div style="border: 1px solid black; padding: 5px; text-align: center;"> <p>RECOVER xx.xx kg</p> </div>
<p>8</p>	<p> WAIT</p>	<p>Suggested weight of refrigerant adding to Work Tank for the first time is 3 to 4 kg.</p> <p>IMPORTANT: When the displayed weight is approximately 3 to 4 kg, close source tank valve and blue quick coupler valve.</p> <p>DO NOT PRESS STOP BUTTON !!</p> <p>When pressure decreases to 0 PSI, system will automatically complete recovery process.</p>	<div style="border: 1px solid black; padding: 5px; text-align: center;"> <p>RECOVER xx.xx kg</p> </div> <p>IMPORTANT: When filling the Work Tank DO NOT LEAVE THE SYSTEM UNATTENDED. ALWAYS TURN OFF SOURCE TANK VALVE FIRST !!</p>
<p>9</p>	<p> WAIT</p>	<p>The screen will display the weight of the refrigerant added to Work Tank and then enter the drain A/C system oil process.</p> <p>Wait for 10 seconds, system will automatically drain the A/C system oil separated from refrigerant.</p>	<div style="border: 1px solid black; padding: 5px; text-align: center;"> <p>RECOVER xx.xx kg</p> </div> <div style="border: 1px solid black; padding: 5px; text-align: center; margin-top: 10px;"> <p>DRAIN OIL</p> </div>

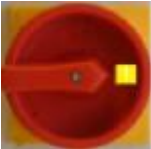







10	WAIT	<ol style="list-style-type: none"> 1、 Draining oil takes about 10 seconds and after the process will stop automatically. 2、 Check oil level in the drain oil bottle, when oil has finished draining out, press STOP to exit. 	<div style="border: 1px solid black; padding: 5px; text-align: center;">DRAIN OIL</div>
11		<p>System enters into System Standby</p> <ol style="list-style-type: none"> 1. xx.xx kg is the weight of the refrigerant in the Work Tank. 2. Turn Source Tank off and Remove Blue quick coupler. 3. Connect quick coupler to its holding port on side of unit. 	<div style="border: 1px solid black; padding: 5px; text-align: center;">WEIGHT xx.xx kg</div>
12	<p>Initial set up is now complete.</p> <p>IMPORTANT: For the normal operation of the system, the weight of the refrigerant in the Work Tank should not be less than 2.5kg.</p>		

[Back to Index](#)

7.2 Printer set-up and operation (optional)



STEP	OPERATE	OPERATING DESCRIPTION	DISPLAY CONTENT
1		<p>Turn the power switch on. Now the system enters into system self-checking state. Program software version is displayed.</p>	<div style="border: 1px solid black; padding: 5px; text-align: center;">VERSION x.xx</div>
2	WAIT	<p>After 3 seconds, the system will display:</p>	<div style="border: 1px solid black; padding: 5px; text-align: center;">WEIGHT xx.xx kg</div>
3	WAIT	<p>Input Company Name: at System Standby;</p> <p>Key input code: 6845</p>	<div style="border: 1px solid black; padding: 5px; text-align: center;">Co.</div>

<p>4</p>	<p> WAIT</p>	<p>Enter Company Name using</p> <p> and  keys to change between upper and lower-case.</p> <p>Press  to delete character.</p>	<p>TEN Automotive Equ</p> <p><i>Note: Max. 36 Characters.</i></p> <p><i>Keyboard operation is similar to that of a mobile phone.</i></p>
<p>5</p>	<p></p>	<p>After inputting Company Name, press START to confirm. The Company name will be stored.</p>	<p>WEIGHT xx.xx kg</p>
<p>6</p>	<p> WAIT</p>	<p>Input Company Telephone No: At System Standby;</p> <p>Key input code: 6302</p>	<p>Tel:</p>
<p>7</p>	<p> WAIT</p>	<p>Enter Company Telephone number;</p> <p>use  to delete.</p>	<p>01553 764900</p>
<p>8</p>	<p></p>	<p>After input, press START to confirm, Company Telephone number will be stored.</p>	<p>WEIGHT xx.xx kg</p>
<p>9</p>	<p></p>	<p>OPERATION:</p> <p>Press PRINT, The screen will alternately show Technician and name of the previous Technician (if applicable).</p> <ol style="list-style-type: none"> If you wish to use the Technician name already in memory, please go to step 11. To input or change the name of the technician, please go to next step, the new name will be saved. 	<p>Technician:</p> <p>XXXXXX</p>

<p>10</p>	<p> WAIT</p>	<p>Input name of Technician:</p> <p>Use  and  to change between upper and lower-case.</p> <p>Use  to delete.</p>	<div style="border: 1px solid black; padding: 5px; width: fit-content;"> XXXXXX ---- </div>
<p>11</p>		<p>Press START The screen will show Vehicle Reg:</p> <ol style="list-style-type: none"> If you don't wish to input vehicle registration number, please go to step 13. If you want to print vehicle registration number, please carry out next step. <p>Note: this number will not be saved.</p>	<div style="border: 1px solid black; padding: 5px; width: fit-content;"> Vehicle Reg: </div> <div style="border: 1px solid black; padding: 5px; width: fit-content; margin-top: 10px;"> ----- </div>
<p>12</p>	<p> WAIT</p>	<p>Input Vehicle Registration number: (if required)</p> <p>Use  and  to change between upper and lower-case.</p> <p>Use  to delete character.</p>	<div style="border: 1px solid black; padding: 5px; width: fit-content;"> ----- </div>
<p>13</p>		<p>After input, press START to print.</p> <p>Note: If you wish to print a duplicate report, press PRINT again.</p>	<div style="border: 1px solid black; padding: 5px; width: fit-content;"> PRINT OK </div>
<p>14</p>		<p>IMPORTANT:</p> <p>If you press STOP, previous recorded information will be deleted</p>	<div style="border: 1px solid black; padding: 5px; width: fit-content;"> WEIGHT xx.xx kg </div>

8: OPERATION

8.1 Recover refrigerant and draining A/C system oil

STEP	OPERATION	OPERATING INSTRUCTION	SCREEN DISPLAY
1		Turn mains power switch on. Now the system enters into system self-checking state and displays software version.	<div style="border: 1px solid black; padding: 5px; display: inline-block;">VERSION x.xx</div>
2	WAIT	After 3 seconds, the system will display the weight of refrigerant in the Work Tank. Connect red and/or blue quick couplers to high and low pressure hoses of the vehicle A/C system and open coupler valves.	<div style="border: 1px solid black; padding: 5px; display: inline-block;">WEIGHT xx.xx kg</div>
3	WAIT	IMPORTANT: Check gauges for vehicle A/C operating pressure. If zero pressure is displayed then check the vehicle A/C system for leaks first. Note: The VACUUM HOLD test is a visual check using the Gauges to look for vacuum decay. It is recommended that the Nitrogen Pressure Test is used for leak detection.	<div style="border: 1px solid black; padding: 5px; display: inline-block;">WEIGHT xx.xx kg</div>
4		Press RECOVER key to enter into recovery procedure. xx.xx kg is reading of headroom left in Work Tank.	<div style="border: 1px solid black; padding: 5px; display: inline-block;">RECOVER xx.xx kg</div>
5		Press the START key to begin recovery. When the pressure in the vehicle A/C system is lower than 0 kpa, the system will automatically complete recovery process.	<div style="border: 1px solid black; padding: 5px; display: inline-block;">RECOVER xx.xx kg</div>

6	WAIT	<p>The screen will display the weight of the refrigerant added to Work Tank and then enter the drain A/C system oil process.</p>	<div data-bbox="979 286 1391 371" style="border: 1px solid black; padding: 5px; text-align: center;">RECOVER xx.xx kg</div>
	WAIT	<p>Wait for 10 seconds, system will <i>automatically</i> drain the vehicle A/C system oil separated from refrigerant.</p>	<div data-bbox="979 456 1391 542" style="border: 1px solid black; padding: 5px; text-align: center;">DRAIN OIL</div>
7	WAIT	<ol style="list-style-type: none"> 1. Draining A/C system oil takes about 10 seconds then stop automatically. 2. Check level in the drain oil bottle, when oil has finished draining the program will automatically stop. 3. The amount of oil drained this time should be noted. <p>You will be prompted to add A/C system oil after vacuuming is complete. Add the required amount specified by the vehicle manufacturer.</p>	<div data-bbox="979 909 1391 994" style="border: 1px solid black; padding: 5px; text-align: center;">DRAIN OIL</div>
8		<p>Press the STOP key to go back to System Standby.</p>	<div data-bbox="979 1368 1391 1453" style="border: 1px solid black; padding: 5px; text-align: center;">WEIGHT xx.xx kg</div>

IMPORTANT:



The recommended filter-drier capacity of this system is 68kg, when recovered refrigerant weight reaches this point the display will read:

CHANGE FILTER

Now filter-drier is no longer effective, and needs to be replaced otherwise damage may occur. (Please refer to [9.2](#) for details).

The self-cleaning procedure will recover the refrigerant in the service hose into the Work Tank. This process will ensure the measurement accuracy of refrigerant. [Back to Index](#)

8.2 Vacuum A/C system and inject new oil

STEP	OPERATION	OPERATING INSTRUCTION	SCREEN DISPLAY
1		Turn the power switch on System Standby will display after 3 seconds.	<div style="border: 1px solid black; padding: 5px; display: inline-block;">WEIGHT xx.xx kg</div>
2		IMPORTANT: If the pressure in the vehicle A/C system is higher than 0kpa, screen will display HIGH PRESSURE. The operator should check the Gauges to confirm system pressure. It is recommended that the operator repeats the recovery process. After the recovery process has automatically completed the pressure should be zero and the vacuuming process can then be carried out normally.	<div style="border: 1px solid black; padding: 5px; display: inline-block;">PRESSURE IN HOSE</div> <div style="border: 1px solid black; padding: 5px; display: inline-block;">VACUUM 15:00</div>
3		Press Number keys to set Vacuum time. Press the START key to begin the vacuuming process.	<div style="border: 1px solid black; padding: 5px; display: inline-block;">VACUUM xx.xx</div>
4	WAIT	Vacuum process (and LP Keeping if selected) is complete.	<div style="border: 1px solid black; padding: 5px; display: inline-block;">INJECT OIL</div>
5	WAIT	Ensure the correct and sufficient oil is in the INJECTED OIL bottle. Press OIL button to inject the amount of new oil required for the vehicle's A/C system.	<div style="border: 1px solid black; padding: 5px; display: inline-block;">INJECT OIL</div>

6		<ol style="list-style-type: none"> 1. After finishing oil injection, press STOP to enter into System Standby. 2. Check pressure gauge to see if vehicle A/C has any leakage, if required. 3. Now press the CHARGE key to charge refrigerant to the vehicle A/C system. 	<div style="border: 1px solid black; padding: 5px; display: inline-block;"> WEIGHT xx.xx kg </div>
---	---	---	---

IMPORTANT:

- 1) If the vacuum pump running time accumulates to 1000 minutes, the system will display: CHANGE OIL.



The vacuum pump oil should be replaced.





Please refer to section [9.4](#) for details. If vacuum pump oil is not replaced at the recommended time, the vacuum pump may incur damaged.

- 2) If A/C system pressure is higher than 50kpa (0.5kg), do not vacuum vehicle A/C system otherwise the vacuum pump may incur damaged.

[Back to Index](#)

8.3 Recharging A/C systems

STEP	OPERATION	OPERATING INSTRUCTION	SCREEN DISPLAY
1		<ol style="list-style-type: none"> 1. Press CHARGE key to enter into refrigerant recharging procedure. 2. Use value keys to set the weight of the refrigerant, specified by the vehicle manufacturer, to charge the vehicle's A/C system. <p>Note: The Work Tank must contain at least 1.2kg more than the charge weight entered. If not, the error message TANK EMPTY? will be displayed.</p> <p>Press STOP to exit program and add refrigerant to Work Tank (Refer to 8.5).</p>	<div style="border: 1px solid black; padding: 10px; display: inline-block;"> TANK EMPTY? </div>

2		<ol style="list-style-type: none"> 1. Press CHARGE key to enter into refrigerant recharging procedure. 2. Use value keys to set the weight of the refrigerant needed to be recharged to vehicle A/C system. 	<div style="border: 1px solid black; padding: 5px; text-align: center;">CHARGE 00.90kg</div>
3		<p>Select charging port. For low pressure charge (default) press START to confirm, or press “up” or “down” keys (▲ or ▼) to select high and/or low pressure charge port mode.</p>	<div style="border: 1px solid black; padding: 5px; text-align: center;">LP CHARGE</div>
4		<p>After selecting high and/or low pressure charge mode, press START to confirm.</p>	<div style="border: 1px solid black; padding: 5px; text-align: center;">LP. HP CHARGE</div>
5		<p>Press START to begin the refrigerant recharging procedure.</p>	<div style="border: 1px solid black; padding: 5px; text-align: center;">CHARGE 00.00kg</div>
6	<p> WAIT</p>	<p>When refrigerant recharging reaches the set value weight the System will stop automatically and indicates the charge amount result at the same time.</p>	<div style="border: 1px solid black; padding: 5px; text-align: center;">CHARGE xx.xx kg</div> <div style="border: 1px solid black; padding: 5px; text-align: center;">CHARGE COMPLETE</div>
7		<p>Press the STOP key for 3 seconds to end the recharging process and return to System Standby.</p> <p>Start the Vehicle A/C system; check the high and low pressure gauges to see if the readings are normal.</p> <p>Close “quick coupler” valves and recover refrigerant from hoses. Disconnect high and low quick couplers.</p> <p>IMPORTANT: Do not exit the program or press stop during hose refrigerant recovery procedure.</p>	<div style="border: 1px solid black; padding: 5px; text-align: center;">WEIGHT xx.xx kg</div>





IMPORTANT:

TANK EMPTY



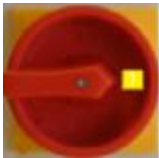

If the system displays TANK EMPTY when you press the CHARGE key then there is insufficient refrigerant in the Work Tank to charge the vehicle A/C system. Press the STOP key to exit the recharging process and add refrigerant to the Work Tank. (Refer to section [8.5](#) for details).

[Back to Index](#)

8.4 Hose recovery and system self-cleaning

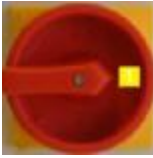
STEP	OPERATION	OPERATING INSTRUCTION	SCREEN DISPLAY
1		Turn the power switch on. From System Standby: 1. Make sure that high and low quick couplers are not connected to vehicle. 2. Ensure that the high and low quick coupler valves are closed.	WEIGHT xx.xx kg
2		Press the RECOVER key to enter into recovery procedure. xx.xx kg is reading of “headroom” left in Work Tank.	RECOVER xx.xx kg
3		Press the START to begin hose recovery or self-cleaning. Check pressure gauge When the pressure is lower than 0kpa, system will automatically complete the process.	RECOVER xx.xx kg
4	WAIT	The screen will display the weight of the refrigerant recovered from hoses and proceed to discharge old A/C system oil and contaminants.	RECOVER xx.xx kg DRAIN OIL
5		When Drain Oil is complete press STOP key down for 3 seconds to go back to System Standby. Hose recovery and system self-cleaning is complete.	WEIGHT xx.xx kg

8.5 Adding refrigerant to work tank







STEP	OPERATION	OPERATING DESCRIPTION	SCREEN DISPLAY
1		Turn the power switch on. Now the system enters into system self-checking state and displays software version.	<div style="border: 1px solid black; padding: 5px; text-align: center;">VERSION: x.xx</div>
2	 WAIT	<ol style="list-style-type: none"> 1、 Connect the Low Pressure male adaptor to the refrigerant source tank 2、 Connect the low pressure “quick coupler” to the male adaptor 3、 Open source tank valve and blue “quick coupler” valve 4、 Turn source tank upside down to increase flow, if required. 	<div style="border: 1px solid black; padding: 5px; text-align: center;">WEIGHT xx.xx kg</div>
3		Press RECOVER key to enter into refrigerant adding procedure xx.xx kg is the amount of refrigerant headroom the Work Tank can contain.	<div style="border: 1px solid black; padding: 5px; text-align: center;">RECOVER xx.xx kg</div>
4		<ol style="list-style-type: none"> 1. Press START to begin the refrigerant top up process. <p>Suggested weight of refrigerant stored in Work Tank is 3 to 4 kg.</p> <p>IMPORTANT: When the displayed weight is approx 3 to 4 kg close the source tank valve and blue quick coupler valve. DO NOT PRESS STOP BUTTON</p> <p>When pressure decreases to 0 PSI the system will automatically complete recovery process.</p>	<div style="border: 1px solid black; padding: 5px; text-align: center;">RECOVER xx.xx kg</div> <p>IMPORTANT: When filling the Work Tank DO NOT LEAVE THE SYSTEM UNATTENDED. ALWAYS TURN OFF SOURCE TANK VALVE FIRST !!</p>







5	WAIT	<ol style="list-style-type: none"> The screen will display the weight of the refrigerant transferred to the Work Tank and then enter the drain oil process. Wait for 10 seconds, the system will automatically drain any A/C system oil or contaminants separated from the refrigerant. 	<div style="border: 1px solid black; padding: 5px; margin-bottom: 5px;">RECOVER xx.xx kg</div> <div style="border: 1px solid black; padding: 5px;">DRAIN OIL</div>
6	WAIT	<ol style="list-style-type: none"> Draining oil takes about 10 seconds and after it will stop automatically. Check oil level in the drain oil bottle and empty if required. 	<div style="border: 1px solid black; padding: 5px; text-align: center;">DRAIN OIL</div>
7		Press the STOP to return to System Standby.	<div style="border: 1px solid black; padding: 5px; text-align: center;">WEIGHT xx.xx kg</div>





[Back to Index](#)



8.6 Fully Automatic Operation

STEP	OPERATION	OPERATING DESCRIPTION	SCREEN DISPLAY
1		<p>Turn the power switch on.</p> <p>Now the system enters into system self-checking state and software version is displayed.</p>	<div style="border: 1px solid black; padding: 5px; text-align: center;">VERSION x.xx</div>
2	WAIT	<p>After 3 seconds, the system will display amount of refrigerant in Work Tank.</p> <p>Connect Red and Blue quick couplers to high and low pressure ports of the vehicle A/C system and open coupler valves.</p> <p>If Applicable; connect N2 hose (yellow) to the Nitrogen source cylinder. Open Nitrogen source valve. The Nitrogen pressure should be greater than 10 bar or the system will not be able to function.</p>	<div style="border: 1px solid black; padding: 5px; text-align: center;">WEIGHT xx.xx kg</div> <p>IMPORTANT: Ensure the INJECTED OIL bottle should contain no less than 30ml of the correct oil.</p>

3		<p>Press START, to program the function sequence selection. Note: The Fully Automatic sequence of operating functions may now be programmed using the number keys 0 through to 7. Please refer to function chart below keypad on unit front panel.</p>	<div style="border: 1px solid black; padding: 5px; text-align: center;">SELECT FUNCTION</div>
4		<p>Press number key 1. Recovery function will be chosen. Press number key 1 again; Recovery function will be cancelled.</p>	<div style="border: 1px solid black; padding: 5px;">R</div>
5		<p>Press number key 2. Nitrogen pressure test will be selected. Press number key 2 again; nitrogen pressure test will be cancelled.</p>	<div style="border: 1px solid black; padding: 5px;">R-N2</div> <div style="border: 1px solid black; padding: 5px;">R</div>
6		<p>Press number key 3. Vacuum function will be chosen. Press number key 3 again; vacuum function will be cancelled.</p>	<div style="border: 1px solid black; padding: 5px;">R-N2-V</div> <div style="border: 1px solid black; padding: 5px;">R-N2</div>
7		<p>Press number key 4, vacuum hold time will be chosen. Press number key 4 again; vacuum hold will be cancelled. NOTE: This is a Pressure Gauge Check only.</p>	<div style="border: 1px solid black; padding: 5px;">R-N2-V-VH</div> <div style="border: 1px solid black; padding: 5px;">R-N2-V</div>
8		<p>Press number key 5. Oil Injection will be selected. Press number key 5 again; Oil Injection will be cancelled.</p>	<div style="border: 1px solid black; padding: 5px;">R-N2-V-VH-I</div> <div style="border: 1px solid black; padding: 5px;">R-N2-V- VH</div>
9		<p>Press number key 6. High and low pressure port refrigerant charging will be selected. Press number key 6 again; high and low pressure refrigerant charging will be cancelled.</p>	<div style="border: 1px solid black; padding: 5px;">R-N2-V- VH -I-C</div> <div style="border: 1px solid black; padding: 5px;">R-N2-V- VH -I</div>

<p>10</p>		<p>Press number key 7. Low pressure port only refrigerant charging will be selected.</p> <p>Press number key 7 again; low pressure port charging will be cancelled.</p>	<div style="border: 1px solid black; padding: 5px; margin-bottom: 5px;">R-N2-V-VH -I-LC</div> <div style="border: 1px solid black; padding: 5px;">R-N2-V-VH -I-</div>
<p>11</p>	 	<p>If you want to exit all the above chosen functions, press STOP to go back to Select Function mode, and press START to return to system standby mode.</p> <p>To confirm the selected functions, press START.</p>	<div style="border: 1px solid black; padding: 5px; text-align: center;">SELECT FUNCTION</div> <div style="text-align: center; margin: 5px 0;">↓</div> <div style="border: 1px solid black; padding: 5px; text-align: center;">WEIGHT xx.xx kg</div>
<p>12</p>		<p>To enter into vacuum time set, and press number keys to set vacuum time value. Then press START.</p>	<div style="border: 1px solid black; padding: 5px;">VACUUM 30:00</div>
<p>13</p>		<p>To enter the amount of oil to recharge set charging weight by number keys. NOTE: Set the amount to 00ML if you wish to enter the amount of oil equal to the amount of drained oil prior to INJECT OIL</p>	<div style="border: 1px solid black; padding: 5px;">OIL 10ML</div>
<p>14</p>		<p>To enter the amount of refrigerant to recharge set charging weight by number keys.</p>	<div style="border: 1px solid black; padding: 5px;">CHARGE 00.90kg</div>
<p>15</p>		<p>IMPORTANT: The Work Tank must contain at least 1.2kg more than the charge weight entered. If not the error message TANK EMPTY? Will be displayed. Press STOP to exit program and add refrigerant to Work Tank (Refer to 4.5).</p>	<div style="border: 1px solid black; padding: 5px;">TANK EMPTY?</div>

<p>16</p>		<p>Press START to enter into setting vacuum hold time, setting keeping time by number keys.</p> <p>Important Note: For indication purposes only. Check Low Vacuum Gauge for excessive Vacuum Decay. Use N2 Leak Test for normal Leak Testing.</p>	<div style="border: 1px solid black; padding: 5px; width: fit-content; margin: auto;"> <p>VAC HOLD 3:00</p> </div>
<p>17</p>		<p>Press START key to enter into N2 leakage detecting time set up. Use value keys to set N2 leakage detecting time needed.</p>	<div style="border: 1px solid black; padding: 5px; width: fit-content; margin: auto;"> <p>N2 LK TEST 15:00</p> </div>
<p>18</p>	 	<p>IMPORTANT: Check gauges for vehicle A/C operating pressure then press START.</p> <p>If zero pressure is displayed then press STOP for 3 seconds to exit the automatic program sequence. Check the vehicle A/C system for leaks first.</p>	<div style="border: 1px solid black; padding: 5px; width: fit-content; margin: auto;"> <p>RECOVER xx.xx kg</p> </div>
<p>19</p>		<p>Press START, System will recycle rest refrigerant from vehicle A/C system automatically. When the recycling pressure is lower than 0 kpa, System will stop recycling automatically, and enter into next programmed operation.</p>	<div style="border: 1px solid black; padding: 5px; width: fit-content; margin: auto;"> <p>RECOVER xx.xx kg</p> </div>
<p>20</p>	<p> WAIT</p>	<p>After recovery is automatically completed, system will automatically enter into oil draining process. Screen will display the weight of refrigerant recovered this time and show that the program has entered the drain oil function.</p>	<div style="border: 1px solid black; padding: 5px; width: fit-content; margin: auto;"> <p>RECOVER xx.xxkg</p> <hr/> <p>DRAIN OIL</p> </div>

21	WAIT	<p>If N2 has been selected then after the recovery and oil draining, the system will automatically enter into N2 charging process. When pressure of N2 charged into air conditioner of vehicle reaches the set value (10bar), N2 charging process will be completed automatically, and system will automatically enter into high pressure leakage detecting process.</p>	<div style="border: 1px solid black; padding: 5px; width: fit-content; margin: auto;">N2 CHARGING</div>
22	WAIT	<p>After N2 charging process is automatically completed,</p> <ol style="list-style-type: none"> 1. Within set time, System will check the leakage for vehicle A/C system. Press STOP to pause the countdown and enter into manual leakage checking procedure. 2. Press START to continue checking leakage automatically. 	<div style="border: 1px solid black; padding: 5px; width: fit-content; margin: auto;">N2 LK TEST 15:00</div>
23		<p>Note:</p> <ol style="list-style-type: none"> 1. Press STOP to pause the countdown to manually check for leaks. 2. Press START to continue leakage checking countdown. 	<div style="border: 1px solid black; padding: 5px; width: fit-content; margin: auto;">N2 LK TEST 15:00</div>
24	<p> WAIT</p>  	<p>Important Note: If 400mbar pressure decay is detected when the preset time is reached the System will display LEAKAGE, and an audible warning will send out simultaneously.</p> <p>Press START to cancel audible warning.</p> <p>Press STOP to discharge and exit Nitrogen pressure test program.</p>	<div style="border: 1px solid black; padding: 5px; width: fit-content; margin: auto;">LEAKAGE</div>

25		<p>Important Note: Please allow 90 seconds for the N2 exhausting process to complete. During this time the system is not operable. This is to ensure complete exhausting of N2 from the system.</p>	<div style="border: 1px solid black; padding: 5px; text-align: center;">EXHAUSTING</div>
26	WAIT	<p>Note: If you press STOP during N2 exhausting process, the System will exit the automatic program and not carry out the other programmed functions (i.e. vacuum, oil injection and charging processes).</p>	<div style="border: 1px solid black; padding: 5px; text-align: center;">EXHAUSTING</div>
27	WAIT	<p>System will automatically enter into Vacuum procedure according to program setting. Vacuum time is preset by the operator.</p>	<div style="border: 1px solid black; padding: 5px; text-align: center;">VACUUM xx.xx</div>
28	WAIT	<p>System will enter into vacuum hold procedure according to program setting automatically, vacuum hold time is set time. Note: This is a Pressure Gauge Check only.</p>	<div style="border: 1px solid black; padding: 5px; text-align: center;">VAC HOLD 3:00</div>
29	WAIT	<p>System will automatically enter into Oil Injection procedure.</p>	<div style="border: 1px solid black; padding: 5px; text-align: center;">INJECT OIL</div>
30	WAIT	<p>System will inject oil approximately to the pre-set amount. NOTE: If the initial amount was set to 0ML then enter the amount of oil to inject at this point.</p>	<div style="border: 1px solid black; padding: 5px; text-align: center;">INJECT xx ML</div>
31	WAIT	<p>System will automatically enter into refrigerant charging procedure. The amount of refrigerant is the preset by the operator.</p>	<div style="border: 1px solid black; padding: 5px; text-align: center;">CHARGE xx.xx kg</div>
32	WAIT	<p>When charging refrigerant reaches preset weight, the System will display CHARGE COMPLETE.</p>	<div style="border: 1px solid black; padding: 5px; text-align: center;">CHARGE xx.xx kg</div> <div style="border: 1px solid black; padding: 5px; text-align: center;">CHARGE COMPLETE</div>



<p>33</p>		<p>Press down STOP key and hold for 3 seconds to return to System Standby.</p> <p>Start Vehicle A/C system; check the high and low pressure gauges to see if the readings are normal.</p> <p>Close “quick coupler” valves and recover refrigerant from hoses. Disconnect high and low quick couplers.</p> <p>IMPORTANT: Do not exit the program or press stop during hose refrigerant recovery procedure.</p>	<div style="border: 1px solid black; padding: 5px; width: fit-content; margin: auto;"> <p>WEIGHT xx.xx kg</p> </div>
-----------	---	--	--

Important Notes:

1. Every function in Automatic Mode has safety pressure detection. Such as: Recycling, Nitrogen Test, Vacuum and Recharge.
2. If the Operator selects Recharging and Oil Injection, the Operator must also choose the Vacuum function simultaneously, otherwise, Oil Injection will not complete. Likewise, when carrying out Vacuuming the Operator should select the Recover function simultaneously, to ensure the system pressure is not higher than 50kpa; otherwise damage may occur to the vacuum pump.
3. If the Operator selects LP keeping function then the Vacuum function must also be selected. We recommend a minimum of 40 minutes Vacuuming if checking for Vacuum decay (LP Keeping)
4. If there is pressure in the vehicle A/C system and the Operator selects the Vacuum function together with any other functions, we recommend that the Recovery function is ALWAYS selected as well as this will prevent damage to the vacuum pump.
5. In Automatic Mode every single function can be linked together according to servicing and repair requirements of vehicle A/C system.
6. When changing between different Injected Oil types ensure the system has fully recovered from the hoses and that there is no residual oil in the Injected Oil bowl feed pipe. **This may cause damage to some A/C Systems especially if they are electrically powered.**
7. **Note: The amount of Oil injected automatically is approximated to take into account the losses due to the length of the Red/Blue connection hoses.**
8. Always check the gauges for normal operating pressure when first connecting to the vehicle A/C system. LP Keeping and the Nitrogen Test are not usually required if the low and high gauges show normal operating pressure with the vehicle A/C system running.

9: ROUTINE DAILY MAINTENANCE

9.1 Checking the capacity of the filter-drier

STEP	OPERATION	OPERATING DESCRIPTION	SCREEN DISPLAY
1		<p>1. At System Standby, press MENU to enter into system organizing procedure</p> <p>2. xx.xx kg represents the weight of the refrigerant the filter-drier has filtered.</p> <p>Please note after 68Kg the filter -drier becomes less effective and requires replacement.</p>	FILTER xx.xx kg
2		Filter-drier requires replacement.	CHANGE FILTER
3		Press STOP to enter into System Standby.	WEIGHT xx.xx kg

Note: It is possible to temporarily override the CHANGE FILTER error message by pressing START, then 3, then START again.



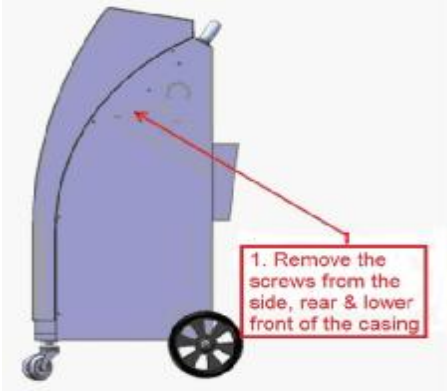
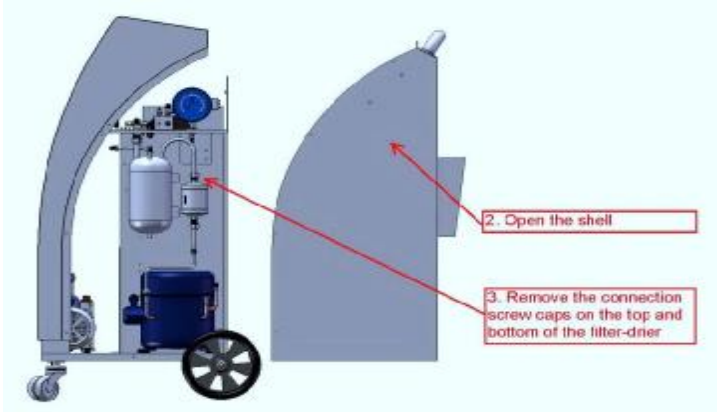
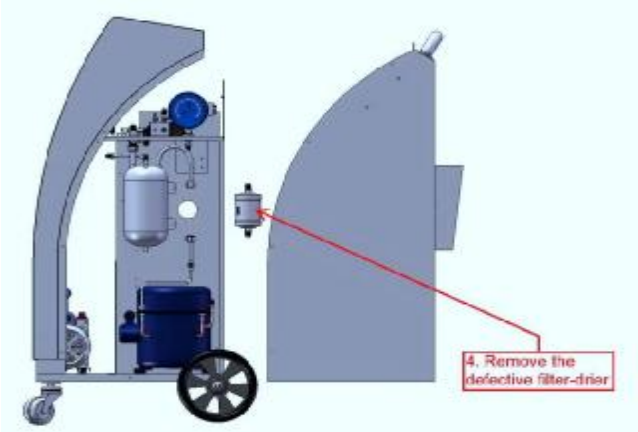

9.2 Changing the filter-drier

STEP	INSTRUCTION
	<p>1) Carry out 4.4 System self-cleaning, wait until it is complete.</p> <p>2) Switch the unit off and isolate mains.</p> <p>3) Most Models of N2Pro have a Filter Drier access panel on the side of the unit. Remove access panel to change Filter-drier.</p> <p>NOTE: Please follow procedure below for Models of N2Pro which do not have the access panel fitted:</p>
<p>1</p>	
<p>2</p>	
<p>3</p>	

<p>4</p>			
<p>5</p>			
<p>6</p>		<ol style="list-style-type: none"> 1. Replace cover and switch unit on. From System Start, press the MENU key to enter into system maintenance option menu. 2. xx.xx kg represents the original value of the filter-drier. 	<div style="border: 1px solid black; padding: 5px; text-align: center;"> <p>FILTER xx.xx kg</p> </div>
<p>7</p>		<ol style="list-style-type: none"> 1. Press “up” key Δ to proceed to CHANGE FILTER 2. Enter the 4 digit reset code **** Press START key 	<div style="border: 1px solid black; padding: 5px; text-align: center;"> <p>CHANGE FILTER</p> </div>
<p>8</p>		<p>Press STOP to enter into System Start.</p> <p>Now new filter-drier value is reset to zero.</p>	<div style="border: 1px solid black; padding: 5px; text-align: center;"> <p>WEIGHT xx.xx kg</p> </div>



[Back to Index](#)

9.3 Checking the vacuum pump oil usage



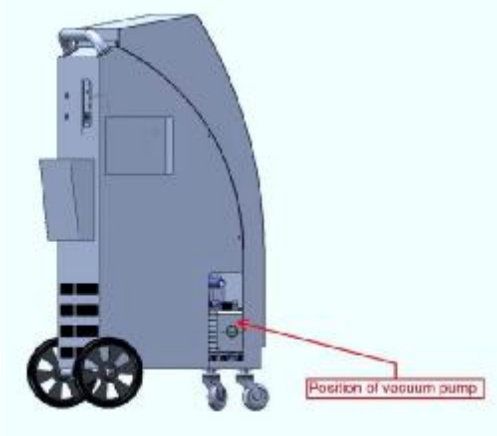
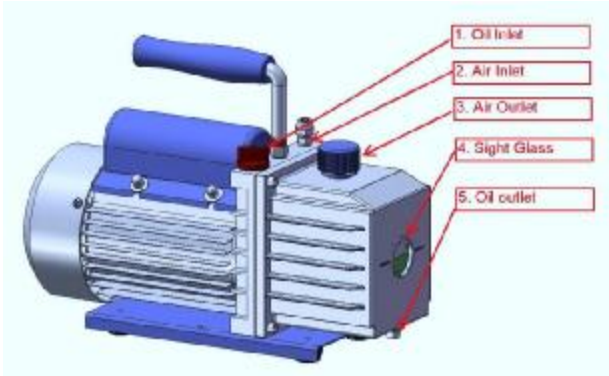

STEP	OPERATION	OPERATING DESCRIPTION	SCREEN DISPLAY
1		At System Standby, press MENU key to enter into system maintenance procedure	<div style="border: 1px solid black; padding: 5px; width: fit-content; margin: auto;"> FILTER xx.xx kg </div>
2		Press “up” key Δ until till the screen displays: xxx MIN represents the accumulated vacuum pump working time. Please note that it is the Manufacturer’s recommendation that the Vacuum Pump Oil is changed after 1000 minutes use.	<div style="border: 1px solid black; padding: 5px; width: fit-content; margin: auto;"> OIL xxx MIN </div>
3		Change Vacuum Pump Oil (Step 5.4) using the correct oil.	<div style="border: 1px solid black; padding: 5px; width: fit-content; margin: auto;"> CHANGE OIL </div>
4		Press STOP key to go back to System Start.	<div style="border: 1px solid black; padding: 5px; width: fit-content; margin: auto;"> WEIGHT xx.xx kg </div>

[Back to Index](#)

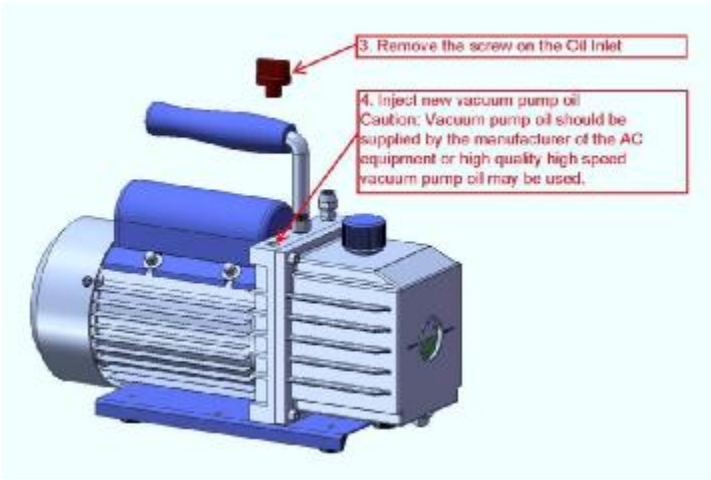
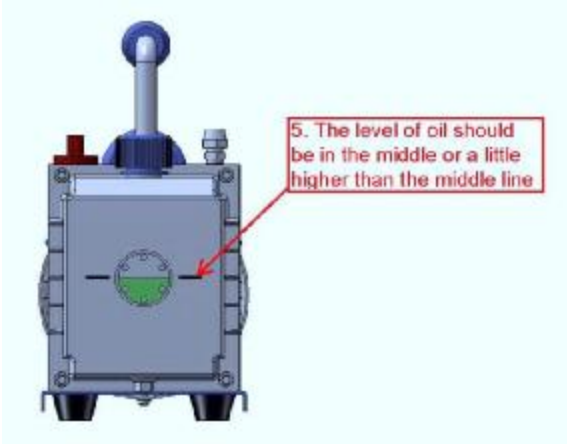
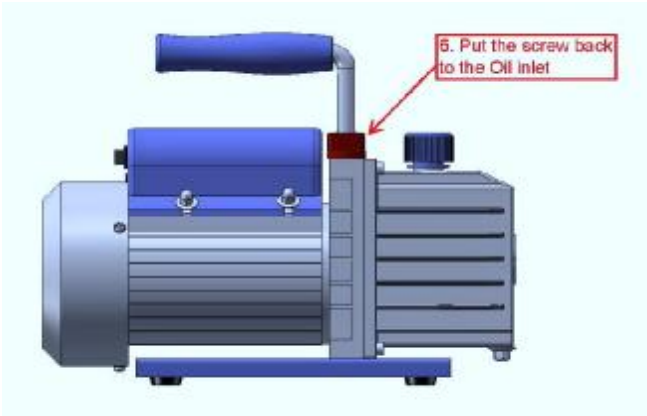
9.4 Replacing vacuum pump oil

STEP	OPERATING DESCRIPTION
	<p>1) Carry out 4.2 Vacuum A/C system. Vacuum time should be set to 2 minutes, wait until it countdown is complete.</p> <p>2) Switch off the unit and change vacuum pump oil as follows:</p>
1	
2	 <p>Note: Some Vacuum Pumps have a combined Air & Oil Inlet</p>
3	

<p>4</p>	
<p>5</p>	
<p>6</p>	
<p>7</p>	

8		Switch on unit. At System Start, press the MENU key to enter into system maintenance procedure.	FILTER xx.xx kg
9		Press Menu key then the “up” key Δ until display shows:: OIL xxx MIN. This represents the previous accumulated vacuum pump work time.	OIL xxx MIN
10		Press “up” key Δ again until display shows: CHANGE OIL. Only if vacuum pump oil has been renewed: 1. Enter the 4 digit reset code **** 2. Press START	CHANGE OIL
11		1. Press STOP key to enter into System Start. 2. Now vacuum pump usage counter is reset.	WEIGHT xx.xx kg

Note: It is possible to temporarily override the CHANGE OIL error message by pressing START, then 4, then START again.

VACUUM PUMP OIL:

This special type of pump oil is strongly recommended since it is specially mixed to ensure viscosity of the oil stays at the maximum at the normal operation temperature of the pump and for start up of the pump at the low temperature.

IMPORTANT:

The system should be checked and maintained periodically, by qualified personnel and in accordance with prevailing EU Environmental Laws.

[Back to Index](#)



10、 SPECIFICATIONS:

Models:	N ² PRO, N ² PRO-1234
Recover rate	5.0g/S
Vacuum speed	2.0L/S
Charge rate	26g/S
Electronic balance sensitivity	±10g
Work tank capacity	10kg
Capacity of filter-drier refrigerant	68kg
Connection port type	R134A (Model: N ² PRO), R-1234YF (Model: N ² PRO-1234).

[Back to Index](#)

11、 SPARE PARTS LIST:

(PART NO.)	(NAME)
AC 1906	<u>POWER SWITCH (Rotary)</u>
AC 1909	<u>POWER CORD (5m)</u>
AC 1912	<u>DRAIN OIL BOWL</u>
AC 1913	<u>INJECT OIL BOWL</u>
AC 1921	<u>HIGH PRESSURE HOSE (RED – Long 500cm)</u>
AC 1922	<u>LOW PRESSURE HOSE (BLUE – Long 500cm)</u>
AC 1923-Y	<u>N2 CONNECTION HOSE (YELLOW–Long 500cm)</u>
AC 1924	<u>HIGH PRESSURE QUICK COUPLER (RED)</u>
AC 1925	<u>LOW PRESSURE QUICK COUPLER (BLUE)</u>
AC 12346	<u>HIGH PRESSURE HOSE (RED – Long 500cm)</u>
AC 12347	<u>LOW PRESSURE HOSE (BLUE – Long 500cm)</u>
AC 1924-1234 *	<u>HIGH PRESSURE QUICK COUPLER (RED)</u>
AC 1925-1234 *	<u>LOW PRESSURE QUICK COUPLER (BLUE)</u>
AC 3000	<u>THERMAL PAPER ROLL (3 Pack)</u>
AC 3001	<u>FILTER DRIER</u>
AC 3002	<u>VACUUM PUMP OIL (1 litre)</u>

* IMPORTANT: Part Numbers listed with -1234 suffixes are specific to model N2PRO-1234 only.

[Back to Index](#)

12、 CONTACT INFORMATION:

TEN Automotive Equipment Limited
 Lubeck Road
 North Lynn Ind Est.
 KINGS LYNN
 Norfolk PE30 2JE
 Tel: + 44 (0)1553 764900
 Fax: +44 (0)1553 770002

www.ten-automotive.co.uk

[Back to Index](#)