

The HD 500™

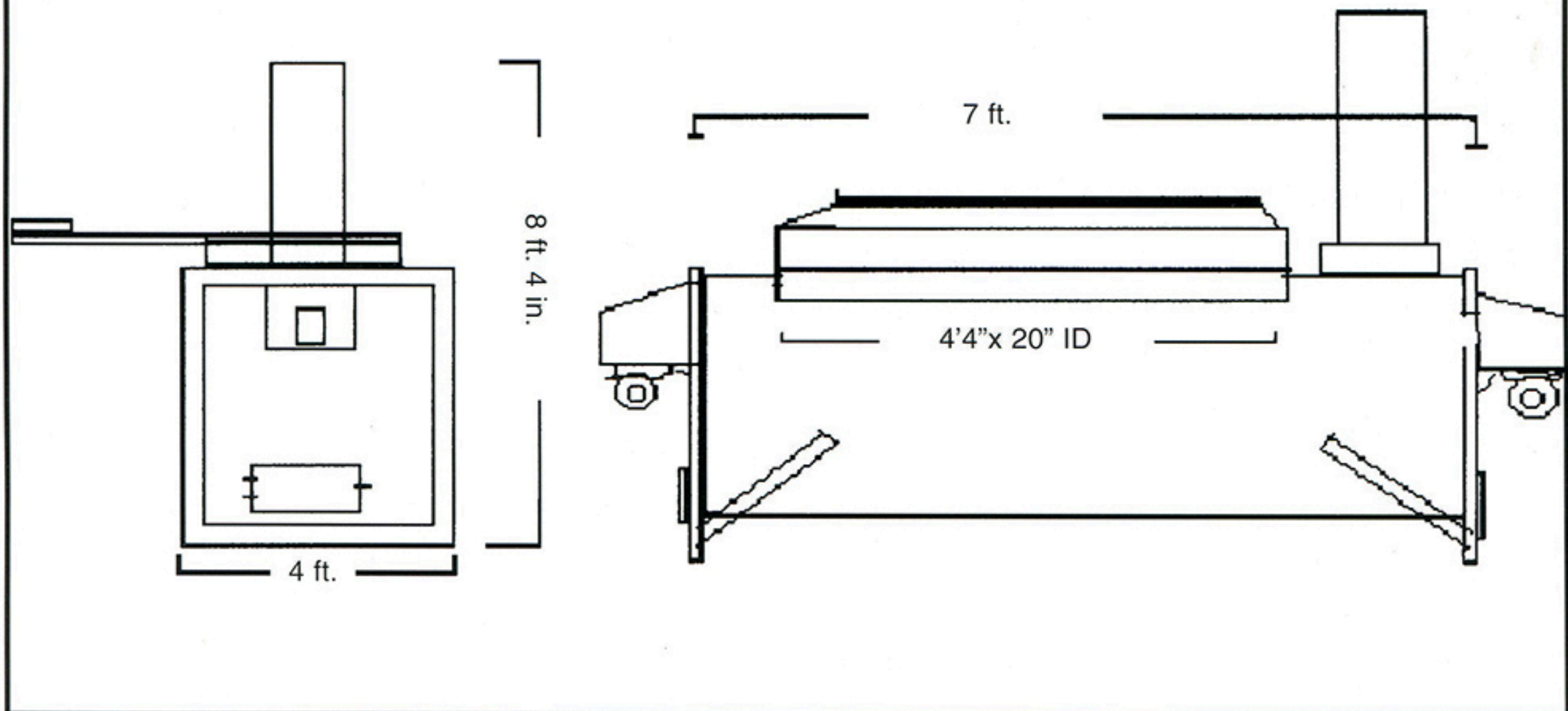

Guarantee

Every unit built by National Incinerator is constructed of the highest quality materials and built by skilled technicians. National's know-how builds into each incinerator bearing their label the assurance of long life and trouble-free operation.

Warranty

National Incinerator, Inc. guarantees all materials and workmanship used in the construction of its incinerator including the refractory for a one year period from date of installation. All purchased electrical parts such as burners, fans, timers, and other controls will carry the applicable manufacturer's guarantee of 90 days. Seller shall not be liable for any injury or damage to person or property or any other incidental or consequential damages.

Specifications

Height: 8'4" **Length:** 7' **Width:** 4'

Weight: 5,000 lbs.

Metal: 11 gauge **Lining:** 3" walls, 4" ends 3000° refractory

Swine

Charge Door: 4'4" x 20" **Lining:** 4" 3,000° refractory

Stack: 4'-4" **Lining:** 2-inch refractory lining

Ash Door: 6" x 11" (both ends) **Lining:** 2-inch 3000° refractory

Grates: No grates

Burner: Two 300,000 BTU incinimite with cover

Clean-out Rod:

Timer: 6 hour



**NATIONAL
INCINERATOR
INCORPORATED**

P.O. BOX 266

BOAZ, AL 35957

(205) 589-6720 • FAX (205) 589-2326