

BEGIN FUSELAGE CONSTRUCTION BY ASSEMBLING TWO SIDES OVER HEAVY BLACK LINES ON PLAN. USE WAX PAPER TO KEEP PARTS FROM STICKING TO PLAN.

JOIN SIDES AT REAR AND CEMENT FORMER 6 IN PLACE. THEN ADD FORMER 4. WHEN CEMENT IS DRY, ADD REMAINING FORMERS.

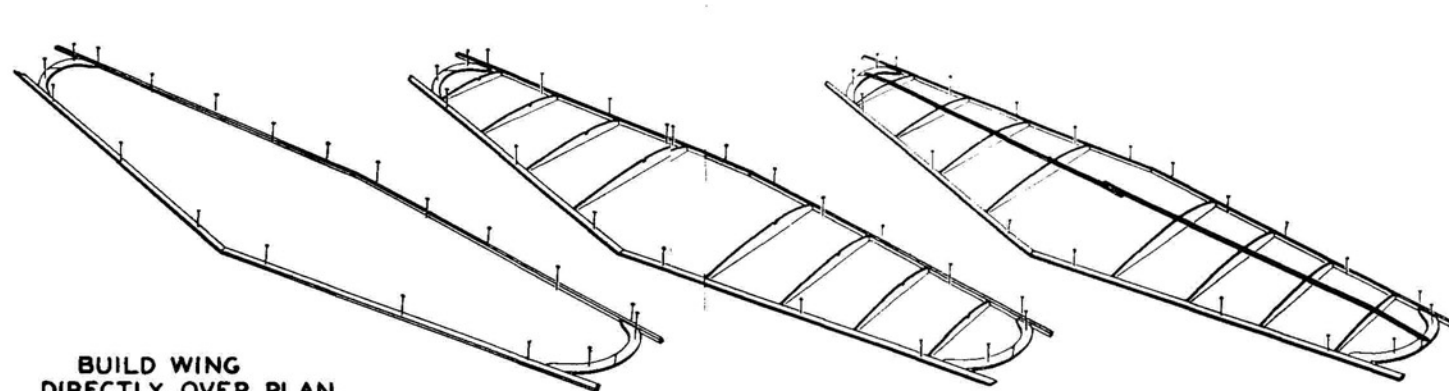

BUILD WING DIRECTLY OVER PLAN. START BY PINNING DOWN THE LEADING AND TRAILING EDGES AND TIPS.

CEMENT WING RIBS IN PLACE.

ADD 1/16" SQ. SPARS.

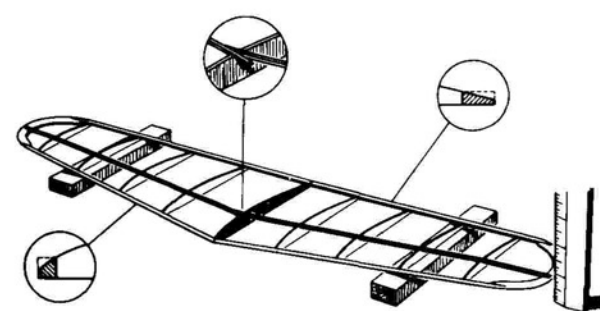
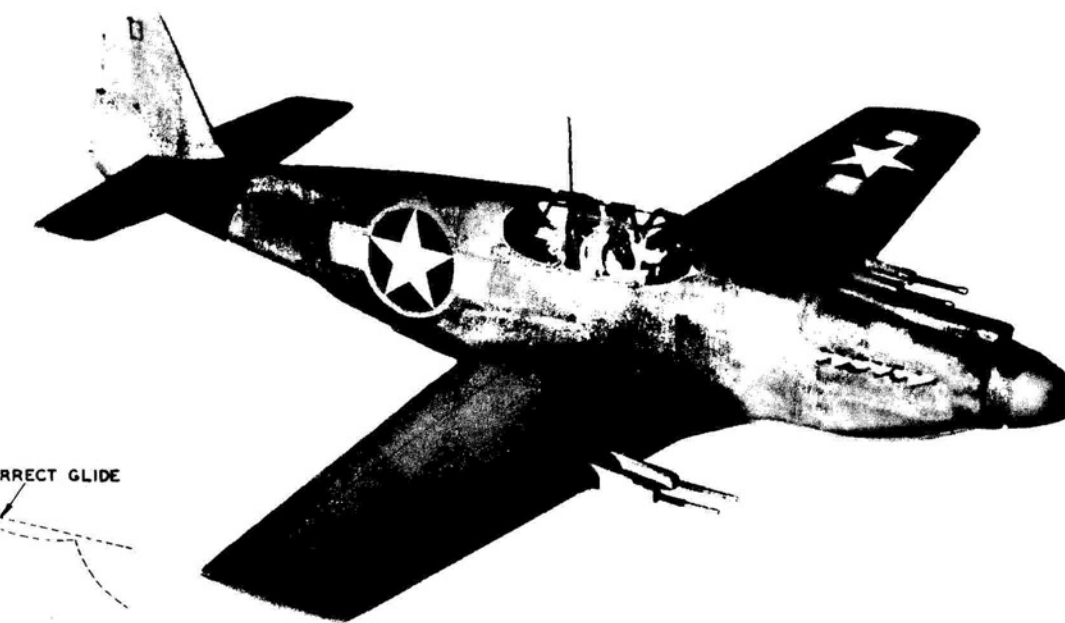

This sketch shows method of putting dihedral angle in wing. Slide convenient blocks under wing until tips are 1/8 inches above the work surface. Bevel ends of leading and trailing edges and glue them together. Next glue in center rib, at the same time gluing top spars together. Sandpaper leading and trailing edges to shape shown.

NOTES ON COVERING

Stick tissue to framework using banana liquid or tissue cement. Fibers of tissue should run the length of part being covered. Use narrow strips for covering rounded fuselages and cover between stringers. After all parts of model have been covered, glue them together and spray lightly with water. This shrinks the tissue smooth. A few coats of banana liquid or clear dope may be applied to keep tissue taut.



Pin to a flat surface and glue prop blades to "A", even with guide lines.

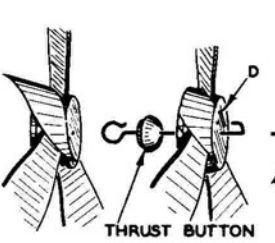

Thrust Button: Cover spaces between blades with paper, trimming to fit before gluing. Slide thrust button and prop on the prop shaft and bend the end over, put glue on it, and push back into part "D". Glue block to front end. When dry, carve and sandpaper to shape of spinner point.

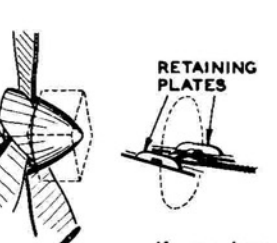

Retaining Plates: If you have a rubber motor equivalent to 4 strands of 1/8" flat you can install it in the following manner. Mount a wood bar behind a convenient former at rear of fuselage. Also glue retaining plates at the sides to longerons and former as illustrated.

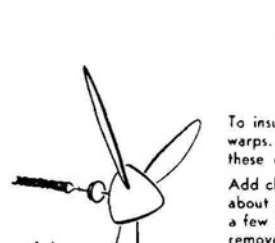

Flying: To insure good flights, the wing and tail surfaces must be without warp. Examine them carefully and if any have developed, straighten these out over heat. Add clay or small tacks to nose of model until it balances at a point about 1/3 back from leading edge of wing (Fig. A). Glide the model a few times. If it stalls add weight to the nose, or if it dives steeply, remove some of the weight (Fig. B). Then try power flights. A lot of fun can be had by whirling the model on a thread. This requires no rubber (Fig. C). Attach thread to a wing tip in line with the balance point of plane. Length of thread can vary, depending on space available. Take-offs can be made easier by shortening the thread and paying it out when model is in the air. With a little practice you can climb or dive the plane by raising or lowering your hand. Perfect take-offs and landings are fun and educational. Spot landing and stuffing contests can be held. Experiments may also be made by tow-launching the model into the air with a length of thread.



Stall: To insure good flights, the wing and tail surfaces must be without warp. Examine them carefully and if any have developed, straighten these out over heat.

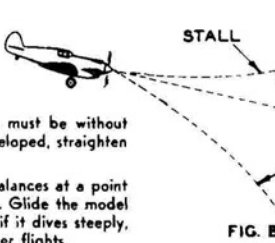

Correct Glide: To insure good flights, the wing and tail surfaces must be without warp. Examine them carefully and if any have developed, straighten these out over heat.

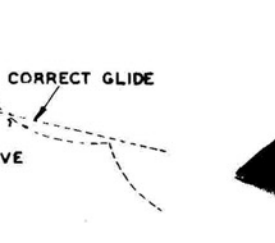

Dive: To insure good flights, the wing and tail surfaces must be without warp. Examine them carefully and if any have developed, straighten these out over heat.

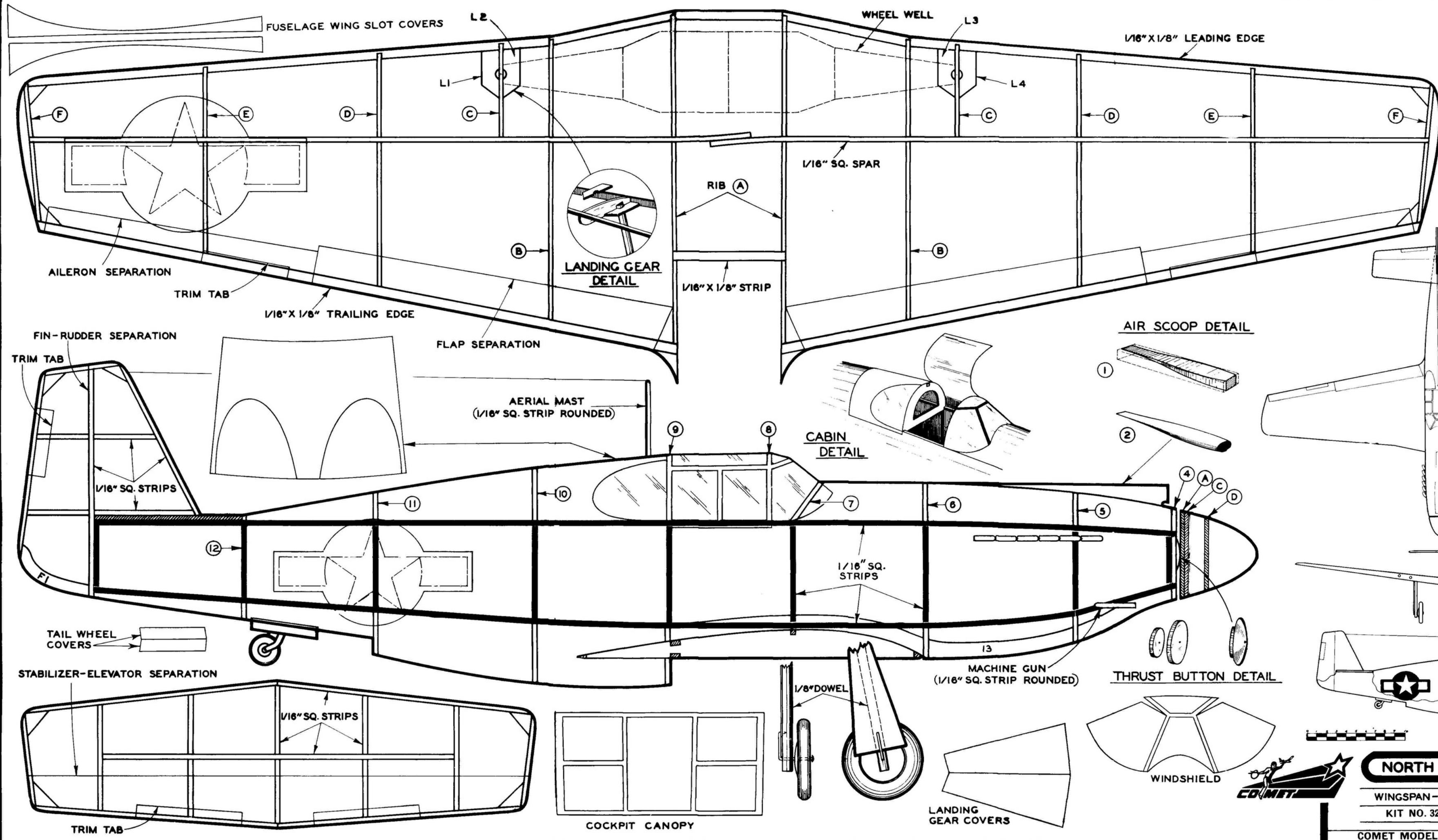

"MUSTANG"
 The U. S. Army's P-51 gained its first real popularity in the Royal Air Force as the "Mustang," a medium and low altitude fighter. It is also used for reconnaissance duties and ground strafing. This plane has been called the "airplane without a mistake" because it went from the design to production without changes. Its clean, low lines give it a speed in excess of 400 M.P.H. Armament is probably six .50 cal. machine guns, two in the nose of fuselage, and four in the wings. Power is supplied by an Allison or Merlin engine. Span is 37 ft. 5/16 in., length 32 ft. 2 5/8 in. Although coloring varies depending on where the plane is used, a good scheme is "sand and spinach" colors in camouflaged pattern on top and light gray on the bottom.

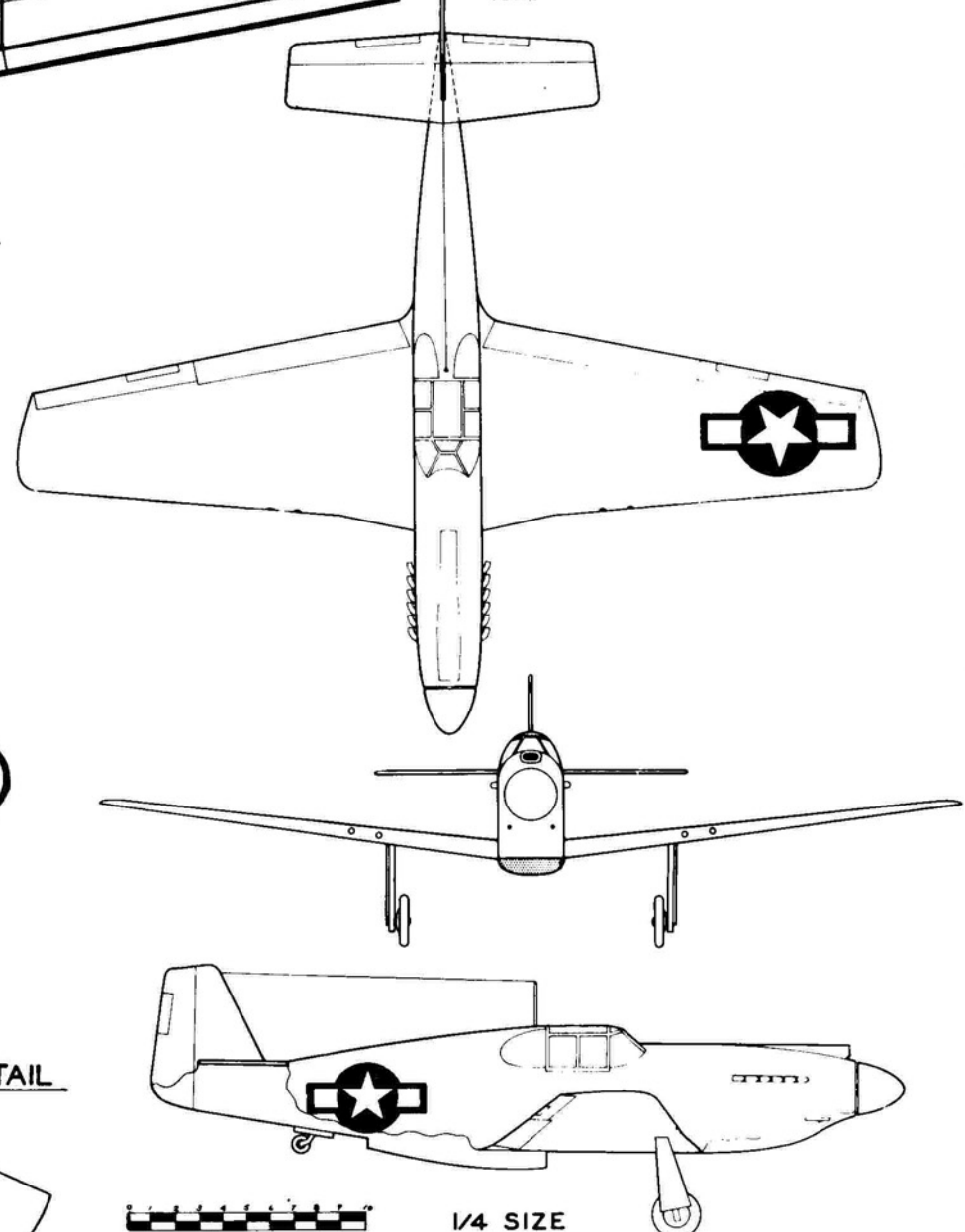

NORTH AMERICAN "MUSTANG" P-51
 WINGSPAN - 18 INCHES LENGTH 15-11/16 INCHES
 KIT NO. 3204 DRAWN BY *Sup. A. I. Iwanenko*
 COMET MODEL HOBBYCRAFT CORP., CHICAGO, ILL.

