

# Operating Instructions for Turbine Wheel Flow Meter

**Model: DOT**



We don't accept warranty and liability claims neither upon this publication nor in case of improper treatment of the described products.

The document may contain technical inaccuracies and typographical errors. The content will be revised on a regular basis. These changes will be implemented in later versions. The described products can be improved and changed at any time without prior notice.

© **Copyright**

**All rights reserved.**

## 1. Contents

---

1. Contents.....	2
2. Note .....	3
3. Instrument Inspection.....	5
4. Regulation Use.....	5
5. Operating Principle.....	6
5.1 K-factor .....	6
5.2 Pressure drop .....	7
5.3 Viscosity effects .....	7
6. Mechanical Connection.....	7
6.1 Meter orientation.....	7
6.2 Flow conditioning .....	7
6.3 Filters.....	8
6.4 Pipeline flushing.....	8
6.5 Entrained Air .....	8
7. Electrical Connection .....	9
7.1 Preamplifier coil .....	10
8. Commissioning.....	10
8.1 Cleaning in place (CIP) .....	11
9. Maintenance .....	11
9.1 Replacing pick-off coil.....	11
9.2 Disassemble .....	11
9.3 Re-assembly.....	11
10. Technical Information.....	12
11. Order Codes .....	13
11.1 Spare parts .....	15
12. Dimensions [ $\pm 2$ mm] .....	15

**Manufactured and sold by:**

Kobold Messring GmbH  
Nordring 22-24  
D-65719 Hofheim  
Tel.: +49(0)6192-2990  
Fax: +49(0)6192-23398  
E-Mail: [info.de@kobold.com](mailto:info.de@kobold.com)  
Internet: [www.kobold.com](http://www.kobold.com)

## **2. Note**

---

Please read these operating instructions before unpacking and putting the unit into operation. Follow the instructions precisely as described herein.

The devices are only to be used, maintained and serviced by persons familiar with these operating instructions and in accordance with local regulations applying to Health & Safety and prevention of accidents.

When used in machines, the measuring unit should be used only when the machines fulfil the EC-machine guidelines.

# DOT

as per PED 2014/68/EU piping  
DOT female thread

Model DOT female thread	DN	P <sub>max</sub> [bar]	diagram 8 group 1 dangerous fluids	diagram 9 group 2 no dangerous fluids
DOT-** G4	15 (½)	250	Art. 4, § 3	Art. 4, § 3
DOT-** G5	20 (¾)	250		
DOT-** G6	25 (1")	250	cat. I	
DOT-** G8	40 (1½")	250		
DOT-** G9	50 (2")	250		
<b>DIN-flange connection</b>	<b>DN</b>	<b>PN</b>		
DOT-** F4	15	16	Art. 4, § 3	Art. 4, § 3
DOT-** F5	20	16		
DOT-** F6	25	16		
DOT-** F8	40	16		
DOT-** F9	50	16		
DOT-** FB	80	16		
DOT-** FC	100	16		
DOT-** FE	150	16	cat. II	
<b>DIN-flange-connection</b>	<b>DN</b>	<b>PN</b>		
DOT-** xx	15	25	Art. 4, § 3	Art. 4, § 3
DOT-** xx	20	25		
DOT-** xx	25	25		
DOT-** xx	40	25		
DOT-** xx	50	25		
DOT-** xx	80	25		
DOT-** xx	100	25		
DOT-** xx	150	25	cat. II	
<b>ASME-flange</b>	<b>DN</b>	<b>Lbs</b>		
DOT-** xx	½"	150	Art. 4, § 3	Art. 4, § 3
DOT-** xx	¾"	150		
DOT-** xx	1"	150		
DOT-** xx	1½"	150		
DOT-** xx	2"	150		
DOT-** xx	½"	300	Art. 4, § 3	Art. 4, § 3
DOT-** xx	¾"	300		
DOT-** xx	1"	300		
DOT-** xx	1½"	300		
DOT-** xx	2"	300		

### **3. Instrument Inspection**

---

Instruments are inspected before shipping and sent out in perfect condition. Should damage to a device be visible, we recommend a thorough inspection of the delivery packaging. In case of damage, please inform your parcel service / forwarding agent immediately, since they are responsible for damages during transit.

**Scope of delivery:**

The standard delivery includes:

- Turbine Wheel Flowmeter model: DOT
- Operating Instructions

### **4. Regulation Use**

---

Any use of the Turbine Wheel Flowmeter, model: DOT, which exceeds the manufacturer's specification, may invalidate its warranty. Therefore, any resulting damage is not the responsibility of the manufacturer. The user assumes all risk for such usage.

## 5. Operating Principle

The DOT turbine flowmeter consists of a helically shaped turbine rotor supported in two tungsten carbide bearings, the rotor being solid ferritic stainless steel of a grade compatible with the metered liquid, all contained within a housing of non-magnetic stainless steel. A pick off coil having a permanent magnet core is mounted in the housing adjacent to the rotor blade tips such that a magnetic circuit is set up via the rotor blades (fig.1).

Rotation of the rotor varies the reluctance of this magnetic circuit and the flux changes induce a small voltage in the coil, the frequency of which is directly proportional to the rotor speed and therefore proportional to the volumetric flow rate.

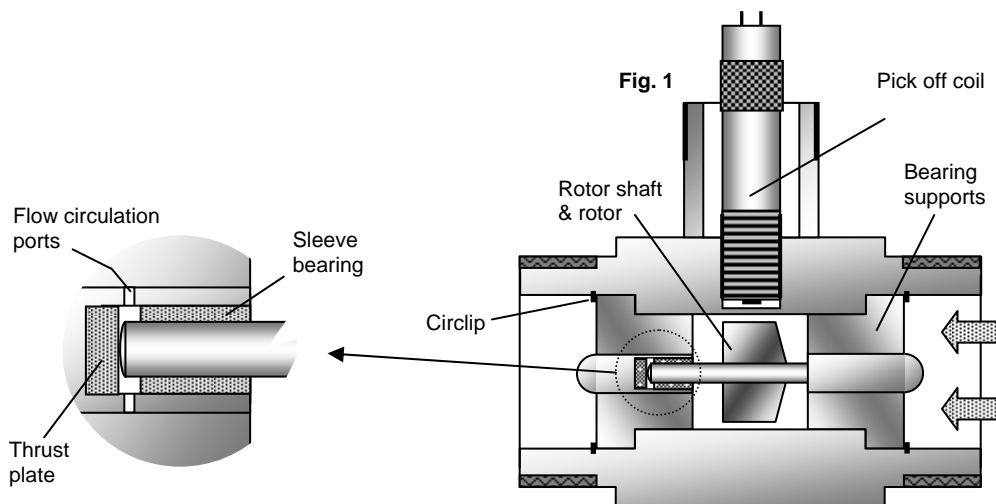

### 5.1 K-factor

Referring to the typical performance curve it will be seen that pulses per unit volume are almost constant over a wide range of flow rates and it is thus possible to establish a meter K-factor (pulses per unit of volume or mass) by which the output pulse must be divided in order to register meaningful engineering units on the associated electronic register / integrator.

Linearity figures vary according to the size of the meter and the metered liquid conditions but are generally within  $\pm 0.5\%$  of reading with point repeatability of  $\pm 0.1\%$  of reading. Linearity over the full flow range is improved to within  $\pm 0.2\%$  of reading when utilising the linearisation program feature of the optional ZOK flow rate totaliser.

## 5.2 Pressure drop

As would be expected with any device with a fixed cross sectional area the pressure drop across the meter varies as the square of the flowrate, for DOT this figure is approximately 0.28 bar (4 psig) on water flow at maximum flowrate for each size meter.

## 5.3 Viscosity effects

The effect of increasing viscosity reduces the linear flowrange and shifts the k-factor. Further, the effect of viscosity depends on the frequency (RPM of rotors). Therefore, smaller the meter, higher is the effect of viscosity on the linearity curve.

# 6. Mechanical Connection

## 6.1 Meter orientation

The meter may be installed in horizontal or vertical pipes, with vertical pipes it is preferred to have the flow passing upward so that any entrained air bubbles will pass quickly. Ensure that the arrow on the meter body is in line with the direction of flow.

## 6.2 Flow conditioning

All turbine flowmeters should be installed with a minimum of ten diameters of straight pipe up-stream and five diameters down-stream (fig. 2), except where the flowmeter is installed directly after a valve or centrifical pump when the minimum straight up-stream length should be increased to 20 diameters. Bends & elbows up-stream of the flowmeter should have a minimum inside radius of twice the diameter of the pipe. Ensure flange gaskets are bore size matched with meter.

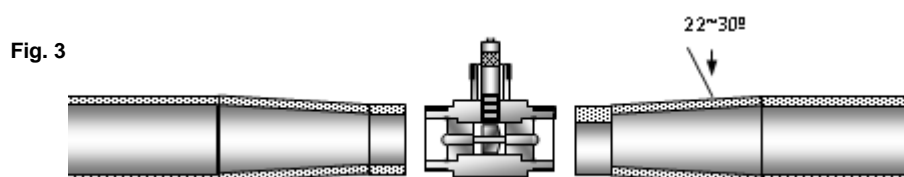
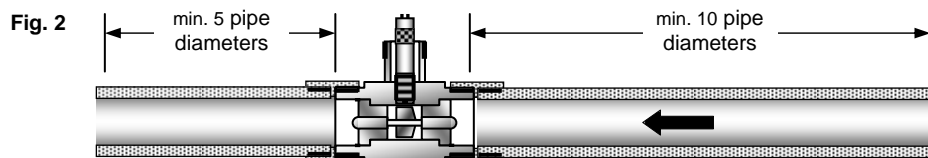

Reducers where necessary should be of the concentric Type with an included angle of 22~30 degrees (fig. 3)

Inlet pipe bore should be matched as closely as possible to that of the meter, but where it is not possible to select the exact inside diameter, a smaller inlet diameter should be used in order to avoid a sharp step at the meter inlet which would cause liquid swirl effecting metering accuracy.

## 6.3 Filters

Whilst most plants requiring precision turbine flowmeters will usually be protected by adequate filters or strainers, the recommended mesh sizes for protection of DOT meters are:

Sizes up to 50 mm	300 microns
Sizes 80 mm bore and above	500 microns

## 6.4 Pipeline flushing

If the DOT meter is installed into a newly fabricated pipe system, the up-stream system must be purged of foreign matters such as welding slag, sealing compounds and other solid materials before installing the flowmeter. Failure to do so may result in serious damage.

## 6.5 Entrained Air

Any turbine flowmeter will register the total amount of fluid passing wether this be all liquid or a mixture of liquid & gases and it is therefore essential to ensure that the pipeline at the meter is completely filled with liquid. Avoid spinning the rotor at speed with air or gas during start up.



## 7. Electrical Connection

Most meters are ordered with the standard non-amplified pick-off coil which produces a flow proportional millivolt sine wave signal between 15~1500mV. Connection to the standard coil output is two wire and insensitive to polarity. The pick-off coil may be tested by measuring the resistance between the two leads, the reading should be between 700~1200 ohms.

### Remote version (in preparation)

Because of the low strength of the standard coil mV output it is important to protect the transmitted signal from any form of electrical interference such as AC line frequencies. A twin core (twisted pair) screened multi-strand signal cable should be used for connection to the pick-off coil, recommended cable size being 16/0.2 x 0.5 mm<sup>2</sup> (16/0.0078). The screen needs to be connected at -0 V at receiving instrument.

Cable runs should be kept well away from high energy power supplies and electricals such as motor speed controllers, transformers and solenoids. Preferably run the cable in a separate conduit to any other wiring.

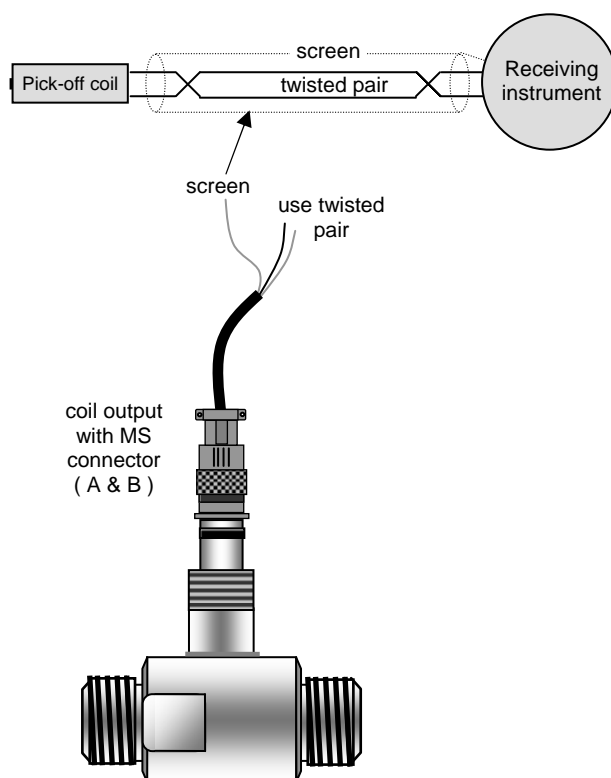

### Compact type

The unit is supplied compactly constructed generally with electronics ZOK or ZOE (option). Please observe the separate operating instructions of ZOK (ZOE) for the pin assignments.

## 7.1 Preamplifier coil

Option „F4S“ is an inductive sensor with integrated preamplifier. Specially designed for Turbine Flowmeters, the sensor provides amplified outputs on 3-wire.

Transmission distance:	max. 500 m
Housing:	stainless steel
Connector:	MS acc. to MIL-DTL-5015 including mating plug with 3x soldering pins
Power supply:	12-24 V <sub>DC</sub>
Pulse output:	NPN, max. 25 mA
Others:	see relevant electronics datasheet ZOK/ZOE
Protection:	IP 55 (with option “F4S”) IP 66/67 (with integrated electronic ZOK/ZOE)

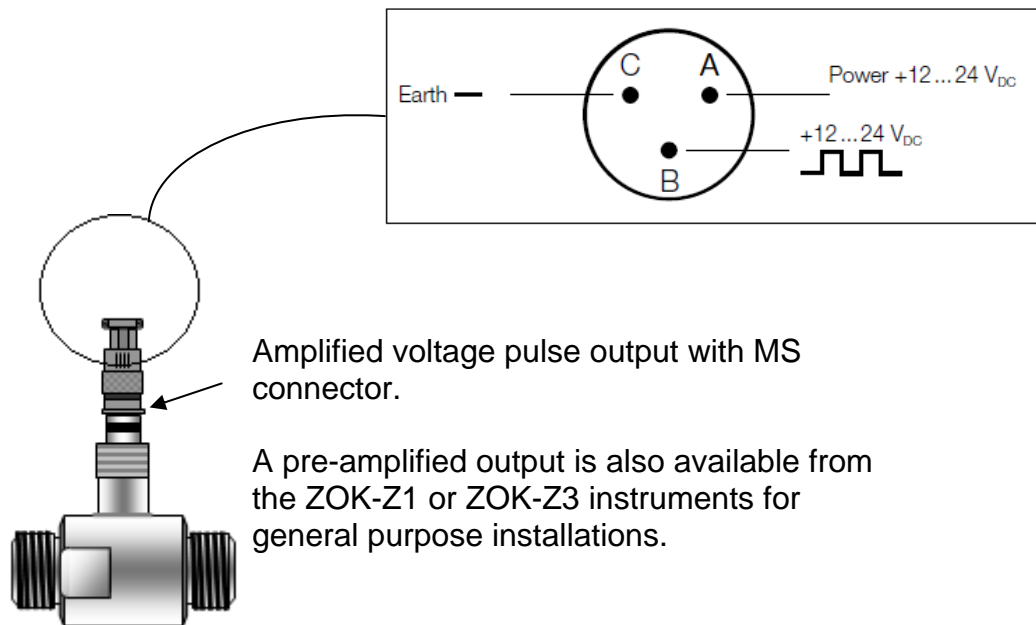

### Important:

We recommend usage of shielded connection cables only, whereby the shield is to be connected only on one side at the evaluating electronics to earth.

## 8. Commissioning

---

Immediately after installation or after long periods of shut down, the meter must be slowly purged of air. Valves should be opened slowly until the meter and upstream pipe work is completely filled with liquid in order to prevent over speeding the rotor.

## 8.1 Cleaning in place (CIP)

When a system is to be cleaned in line, sterilised or purged without removal of the meter from the pipeline, it is advisable to provide a by-pass around the meter to avoid damage to the rotor and bearings, unless the following recommendations can be adhered to:

- \* The cleaning liquids must be compatible with the materials of the meter.
- \* When steam sterilising, ensure that the steam temperature does not exceed the maximum operating temperature of the meter. The velocity of steam must be carefully restricted so that the speed of the turbine is kept below the speed of maximum flow rate on liquids. The same restrictions apply when purging with air or gas.

## 9. Maintenance

### 9.1 Replacing pick-off coil

When replacing the pick-off coil it must be hand tightened only, avoid using a wrench or pliers.

### 9.2 Disassemble

All internals are disassembled in turn through the end of the meter body. Take special note of the position and varying diameters of the two bearing supports so that these may be replaced in the same position and reverse sequence during re-assembly.

There are several different forms of retainment of the internals; these are dependent on meter size. Sizes 15~50 mm (1/2"~2") use a circlip, 80 mm (3") has a retaining ring and larger sizes use a slotted locking tab and hub nut. Always use a soft aluminum drift and light hammer when removing the bearing supports.

### 9.3 Re-assembly

Re-assemble the internals in the reverse order giving particular to the flow direction of the rotor, the leading edge of the rotor blades are angled and the trailing edges are squared off (fig. 5).

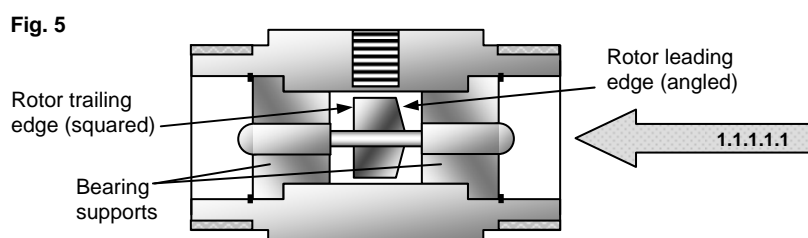

## 10. Technical Information

---

Sizes:	15 mm...300 mm (1/2" ...12" ANSI, DN 15...DN300), bigger on request (see model no. designation for information on available sizes)
Linearity:	± 0.5% of reading (± 0.2% when utilising the linearisation feature of electronic type Z3)
Repeatability:	± 0.02...0.05% under steady flow conditions
Max. pressure:	threaded connections: 250 bar Flange connections: corresponding to flange specifications
Temperature range:	-20...+120 °C (ambient temperature max. +80 °C)
Pressure drop:	approx. 0.28 bar at maximum flow (SG = 1.0, Vis.= 1 mm <sup>2</sup> /s)
Supply voltage:	see electronics
Electronic features:	see comparison table
Flanges:	acc. to DIN 2501 or ASME B16.5 (optional)
<b>Materials:</b>	
Housing:	Stainless steel 1.4401 (316 SS)
Flanges:	Stainless steel 1.4401 (316 SS) or carbon steel A 106
Rotor:	SS 430 (up to DOT-xx15), SS ANC 21 (Duplex stainless steel for bigger sizes)
Bearing support:	Stainless steel 1.4401 (316 SS)
Bearings:	tungsten carbide (shaft, bush, thrust plates)
<b>Output:</b>	
Preamplifier:	Inductive sensor in option "F4S" is a turbine wheel sensor with integrated preamplifier. Specially designed for Turbine Flowmeters, the sensor provides amplified output on 3-wire
Transmission distance:	max. 500 m
Connector:	MS acc. to MIL-DTL-5015 including mating plug with 3x soldering pins
Power supply:	12-24 V <sub>DC</sub>
Pulse output:	NPN, max. 25 mA
Others:	see relevant electronics datasheets ZOK/ZOE
Protection:	IP 55 (with option "F4S") IP 66/67 (with integrated electronic ZOK/ZOE)
<b>Recommended filters:</b>	
Sizes up to DN50:	0.3 mm (300 µm or 60 mesh)
Sizes from DN80:	0.5 mm (500 µm or 100 mesh)

## 11. Order Codes

### Order details for threaded version (example: DOT-13 15H G5 Z3M B)

Housing/ Connection material	Range	Mechanical connection*	Electronics/ cable entry/ plug	Flow direction
DOT-13 = (st. steel/ st. steel)	05H = 0.11 – 1.1 m <sup>3</sup> /h	G4 = ½" male	F4S = only pulse output/ pre-amplified/ MS (military style) connector for max. 120 °C Z1M = electronic ZOK-Z1/ M20x1.5 Z2M = electronic ZOK-Z2/ M20x1.5 Z3M = electronic ZOK-Z3/ M20x1.5	<b>0</b> = all directions (only pulse output) <b>B</b> = from bottom to top, indication right <b>M</b> = from bottom to top, indication left <b>L</b> = from left to right, indication on top <b>R</b> = from right to left, indication on top
	10H = 0.22-2.2 m <sup>3</sup> /h 15H = 0.4-4.0 m <sup>3</sup> /h 20H = 0.8-8 m <sup>3</sup> /h	G5 = ¾" male		
	25H = 1.6-16 m <sup>3</sup> /h	G6 = 1" male	Z1N = electronic ZOK-Z1/ ½" NPT Z2N = electronic ZOK-Z2/ ½" NPT Z3N = electronic ZOK-Z3/ ½" NPT	
	30H = 3.4-34 m <sup>3</sup> /h	G8 = 1½" male	ZEN = electronic ZOE with external supply/ ½" NPT ZBN = electronic ZOE without external supply/ with battery/ ½" NPT	
	35H = 6.8-68 m <sup>3</sup> /h	G9 = 2" male	XX = special option	
	XXH = special option		XX = special option	

\* Replace DOT-xxxxGx...into DOT-xxxxNx for NPT connection

## Order details for flanged version (example: DOT-13 50H FE Z3M B)

Housing/ Connection material	Range	Mechanical connection	Electronics/ cable entry/ plug	Special options
<b>DOT-12</b> = (st. steel/ carbon steel)  <b>DOT-13</b> = (st. steel/ stainless steel)	<b>05H</b> = 0.11 – 1.1 m <sup>3</sup> /h	<b>F4</b> = DN 15, PN 16	<b>F4S</b> = only pulse output/ pre-amplified/ MS (military style) connector for max. 120 °C  <b>Z1M</b> = electronic ZOK-Z1/ M20x1.5  <b>Z2M</b> = electronic ZOK-Z2/ M20x1.5  <b>Z3M</b> = electronic ZOK-Z3/ M20x1.5  <b>ZEM</b> = electronic ZOE with external supply/ with battery/ M20x1.5  <b>ZBM</b> = electronic ZOE without external supply/ M20x1.5  <b>Z1N</b> = electronic ZOK-Z1/ ½" NPT  <b>Z2N</b> = electronic ZOK-Z2/ ½" NPT  <b>Z3N</b> = electronic ZOK-Z3/ ½" NPT  <b>ZEN</b> = electronic ZOE with external supply/ ½" NPT  <b>ZBN</b> = electronic ZOE without external supply/ with battery/ ½" NPT	<b>O</b> = all directions (only pulse output)  <b>B</b> = from bottom to top, indication right  <b>M</b> = from bottom to top, indication left  <b>L</b> = from left to right, indication on top  <b>R</b> = from right to left, indication on top
	<b>10H</b> = 0.22-2.2 m <sup>3</sup> /h <b>15H</b> = 0.4-4.0 m <sup>3</sup> /h <b>20H</b> = 0.8-8 m <sup>3</sup> /h	<b>F5</b> = DN 20, PN 16		
	<b>25H</b> = 1.6-16 m <sup>3</sup> /h	<b>F6</b> = DN 25, PN 16		
	<b>30H</b> = 3.4-34 m <sup>3</sup> /h	<b>F8</b> = DN 40, PN 16		
	<b>35H</b> = 6.8-68 m <sup>3</sup> /h	<b>F9</b> = DN 50, PN 16		
	<b>40H</b> = 13.5-135 m <sup>3</sup> /h	<b>FB</b> = DN 80, PN 16		
	<b>45H</b> = 27-270 m <sup>3</sup> /h	<b>FC</b> = DN 100, PN 16		
	<b>50H</b> = 55-550 m <sup>3</sup> /h	<b>FE</b> = DN 150, PN 16		
<b>XXH</b> = special option	<b>XX</b> = special option	<b>XX</b> = special option		

\* Change DOT-xxxxFx...into DOT-xxxxHx...for PN25

Change DOT-xxxxFx...into DOT-xxxxAx... for ANSI 150 RF or into DOT-xxxxBx... for ANSI 300 RF

## 11.1 Spare parts

Calibrated measuring element assembly	Suit meter	Part No.
Rotor & shaft, Bearings and bearing supports + circlip  <b>Note:</b> The calibrated measuring elements are supplied with a new calibration report which in most cases will have a new K-factor than that of the original meter elements.	DOT-xx05	ERS-DOTMEA010
	DOT-xx10	ERS-DOTMEA012
	DOT-xx15	ERS-DOTMEA015
	DOT-xx20	ERS-DOTMEA020
	DOT-xx25	ERS-DOTMEA025
	DOT-xx30	ERS-DOTMEA040
	DOT-xx35	ERS-DOTMEA050
	DOT-xx40	ERS-DOTMEA080
	DOT-xx45	ERS-DOTMEA0100
	DOT-xx50	ERS-DOTMEA0150

Pick off Coils	Part No.
Standard pick off coil to 120°C (250°F) with MS connector pins	ERS-DOTPC802MS
Standard pick off coil to 120°C (250°F) with flying leads	ERS-DOTPC802FL
Pre-amplified current modulated pick off coil with MS connector 65°C (150°F)	ERS-DOTPUA8700MS
Herm sealed, High temp. pick off coil to 240°C (460°F) with leads	ERS-PC559G
Herm sealed, High temp. pick off coil to 240°C (460°F) with MS connector pins	ERS-DOTPC558G

## 12. Dimensions [±2 mm]

### Threaded metres

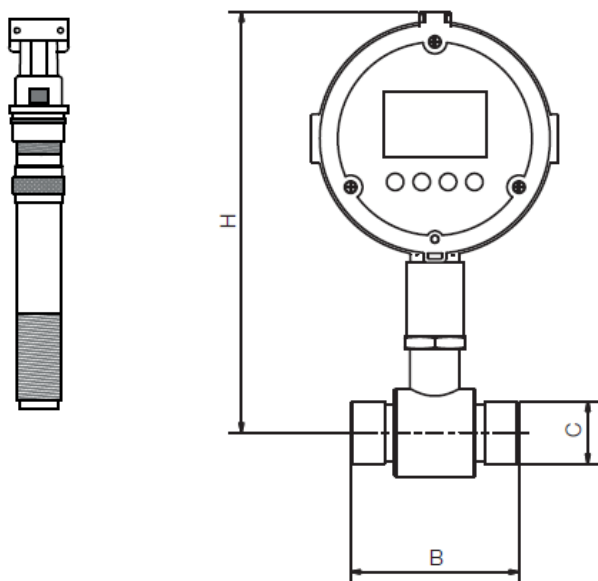

Flow	C	B	H (with pulse output)	H (with ZOK electronics)
m <sup>3</sup> /h	Thread	mm	mm	mm
0.11-1.1	½"	64	150	222
0.22-2.2	¾"	65	152	222
0.4-4	¾"	65	152	222
0.8-8	¾"	83	154	223
1.6-16	1"	88	158	226
3.4-34	1½"	114	164	233
6.8-68	2"	132	169	237

## Flanged metres

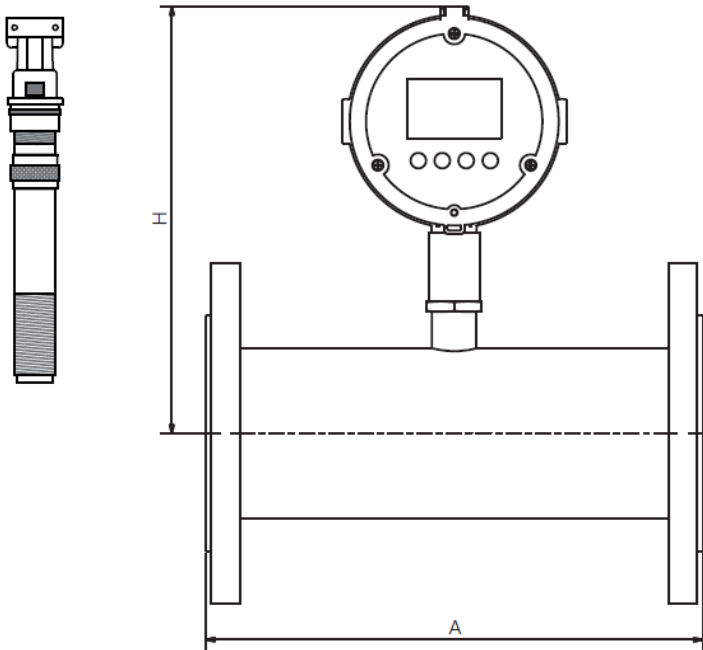

Flow	A	H (with pulse output)	H (with ZOK electronics)
m <sup>3</sup> /h	mm	mm	mm
0.11-1.1	127	150	219
0.22-2.2	127	152	219
0.4-4	127	152	219
0.8-8	140	154	222
1.6-16	152	158	228
3.4-34	178	164	231
6.8-68	197	169	237
13.5-135	254	178	249
27-270	356	197	268
55-550	368	222	298

## Clamp ferrule (Tri-Clamp®) (according to DIN32676)

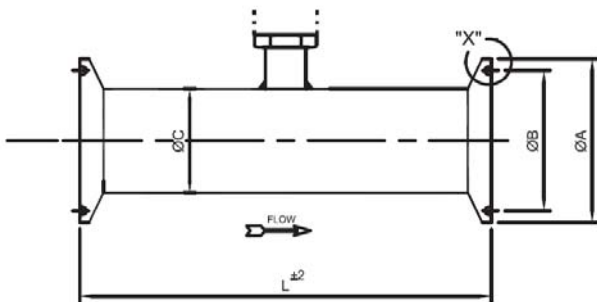

Model	±0.1 ØA	±0.1 ØB	±0.025 ØC	±0.1 F	±2 L
DOT-1305	50.5	43.5	31.7	2.85	127
DOT-1310	50.5	43.5	31.7	2.85	127
DOT-1315	50.5	43.5	31.7	2.85	127
DOT-1320	50.5	43.5	35.0	2.85	140
DOT-1325	50.5	43.5	38.1	2.85	152
DOT-1330	50.5	43.5	57.2	2.85	178
DOT-1335	64.0	56.3	69.5	2.85	197

Detail »X«

