

Angle Cut Cylinder 22°	STOCK
A X B	
7/8 X 1 3/4	N
7/8 X 1 5/8	LL • MC • FC
7/8 X 1 1/2	N
5/8 X 1 1/2	LL • MC • SMC
5/8 X 1 1/4	LL • MC
5/8 X 1 1/8	LL • MC • FC
1/2 X 7/8	MC
7/16 X 3/4	LL • MC • FC
3/8 X 7/8	LL • MC • FC
3/8 X 5/8	P • LL • MC • FC
5/16 X 3/4	P • LL • MC • FC
5/16 X 5/8	LL • MC • FC
1/4 X 3/4	MC
1/4 X 5/8	LL • MC • FC
3/16 X 3/8	LL • MC
3/16 X 5/16	P • LL • MC • FC
5/32 X 5/16	N

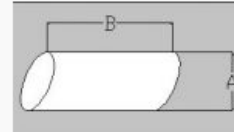

Angle Cut Cylinder 45°	STOCK
A X B	
5/8 X 1 1/4	LL • MC • FC
1/2 X 1 1/8	MC
1/2 X 5/8	LL • MC • FC
7/16 X 3/4	MC
3/8 X 7/8	LL • MC • FC
3/8 X 5/8	LL • MC • FC

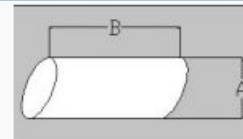

Angle Cut Cylinder 60°	STOCK
A X B	
3/8 X 9/16	N
5/16 X 9/16	N
1/4 X 9/16	LL

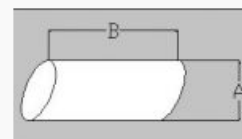

Angle Cut Triangle 22°	STOCK
A X B	
2 X 5/8	LL • MC • FC
2 X 7/8	N
2 X 2	MC • FC
1 7/8 X 5/8	N
1 1/2 X 1/2	LL • MC • FC
1 3/8 X 1/2	N
1 1/8 X 1 1/8	LL • MC • FC
1 1/8 X 7/8	MC
1 1/8 X 5/8	MC
1 1/8 X 3/8	LL • MC • FC
1 1/8 X 5/16	LL • MC • FC
7/8 X 15/16	LL • MC
7/8 X 7/8	LL • MC • SMC • FC
7/8 X 5/8	MC
7/8 X 3/8	LL • MC • FC
7/8 X 5/16	LL • MC • FC
5/8 X 5/8	LL • MC • FC
5/8 X 3/8	LL • MC
5/8 X 5/16	LL • MC • FC
5/8 X 1/4	MC
3/8 X 3/8	MC • FC
3/8 X 5/16	P • LL • MC • FC
3/8 X 1/4	LL • MC • SMC • FC
1/4 X 1/4	LL • MC • FC
1/4 X 3/16	N

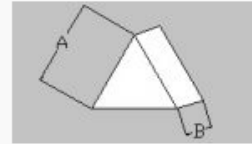

UltraMatic Media Sizes

N=Non-Standard

Angle Cut Triangle 45° & 60°	STOCK
A X B	
1 1/8 X 1 1/8 45°	LL • MC • FC
7/8 X 7/8 45°	LL • MC • FC
5/8 X 5/8 45°	LL • MC • SMC • FC
5/8 X 1/2 45°	LL • MC • SMC • FC
3/8 X 3/8 60°	LL • MC • SMC • FC

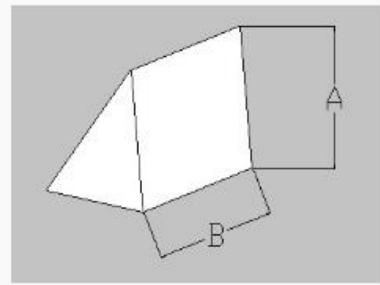

V Cut Cylinder	STOCK
A X B	
2 X 2	MC • FC
1 3/4 X 1 3/4	FC
1 1/2 X 1 1/2	LL • MC • FC
1 1/4 X 1 1/4	MC • FC
1 X 1	LL • MC • SMC • FC
7/8 X 7/8	LL • MC • FC
3/4 X 3/4	MC • FC
5/8 X 5/8	LL • MC • FC
1/2 X 1/2	P • LL • MC • FC
3/8 X 3/8	P • LL • MC • FC

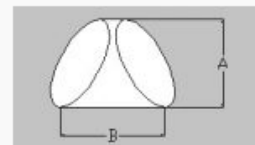

Angle Cut TriStar	STOCK
A X B	
1 7/8 X 5/8	MC • FC
1 1/2 X 1/2	N
1 3/8 X 1/2	MC • FC
1 3/8 X 7/16	N
1 3/8 X 3/8	LL • MC • FC
1 1/8 X 5/8	N
1 1/8 X 3/8	MC • FC
1 1/8 X 5/16	LL • MC • FC
7/8 X 3/8	LL • MC • FC
7/8 X 5/16	LL • MC • FC
5/8 X 3/8	LL • MC • FC
5/8 X 5/16	LL • MC • FC
5/8 X 1/4	MC • FC
3/8 X 1/4	LL • MC • FC

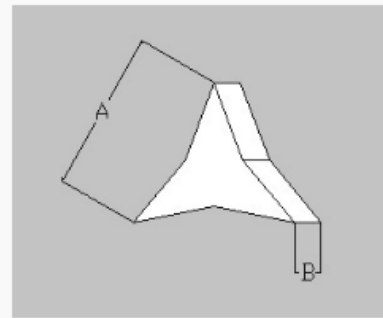

Cones	STOCK
A X B	
1 1/4 X 1 1/4	LL • MC • FC
1 1/8 X 1 1/4	P • LL • MC • FC
3/4 X 7/8	LL • MC • SMC • FC
1/2 X 5/8	P • LL

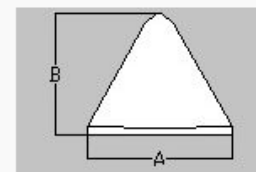

UltraMatic Media Sizes

N=Non-Standard

Ellipse	STOCK
A X B X C	
1 X 3/8 X 1	LL • MC • FC
1/2 X 1/4 X 1/2	LL • MC • FC
5/16 X 3/16 X 1/2	N

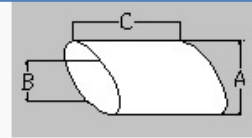

Angle Cut Ellipse 22°	STOCK
A X B X C	
1 X 3/8 X 1	LL • MC • FC
3/8 X 5/8 X 7/8	N

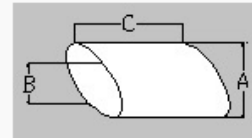

Straight Cut Triangle	STOCK
A X B	
7/8 X 5/8	MC
3/8 X 3/8	N
1/4 X 1/4	N

