

Comet Senior Dart

Wingspan - 24"

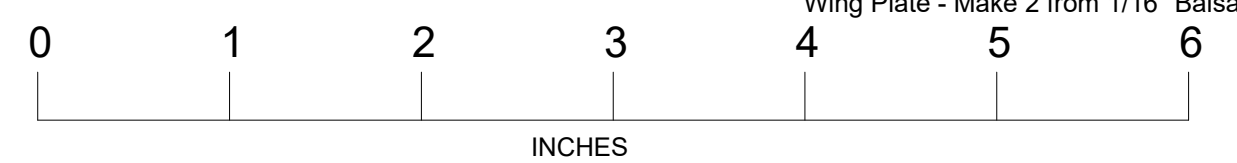

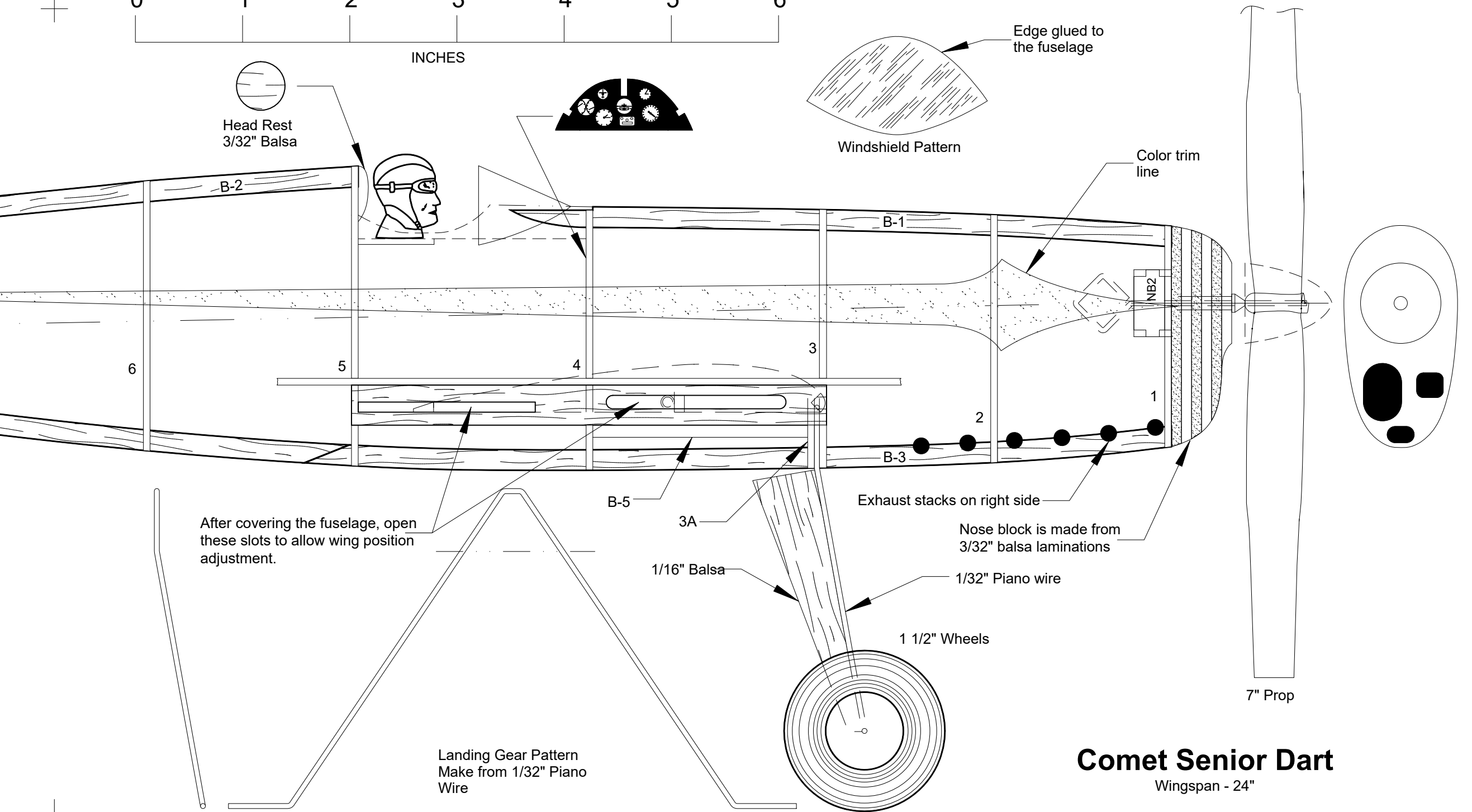
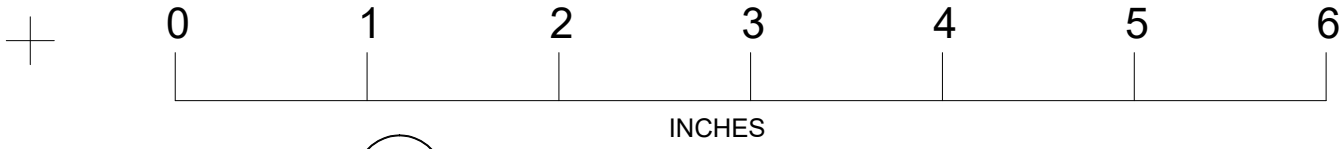

Head Rest
3/32" Balsa

Edge glued to the fuselage
Windshield Pattern

Color trim line

After covering the fuselage, open these slots to allow wing position adjustment.

Exhaust stacks on right side

Nose block is made from 3/32" balsa laminations

1/16" Balsa

1/32" Piano wire

1 1/2" Wheels

7" Prop

Landing Gear Pattern
Make from 1/32" Piano Wire

Comet Senior Dart

Wingspan - 24"

Comet Senior Dart

Wingspan - 24"

CAD Drawing by Paul Bradley

Sheet 3 of 6

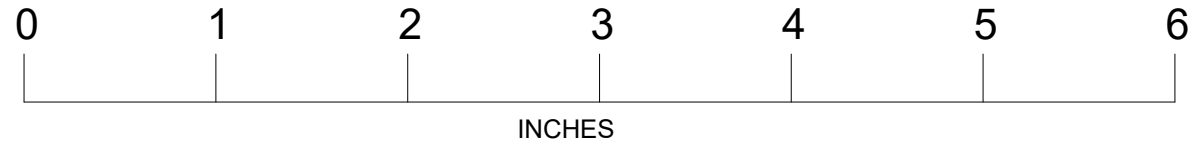

NOTE: A center of gravity location is not shown on the plan. The wing is set up to allow movement fore and aft. With a loop of rubber in the fuselage, test glide the model. Adjust the position of the wing to produce a glide without stalls or diving hard to the ground. The magnets in each aluminum wing tube will pull the wing panels tight against the fuselage. Once you have the wing located where a good flight trim is achieved, mark the wing location or glue the wing tube mount to the center keel.

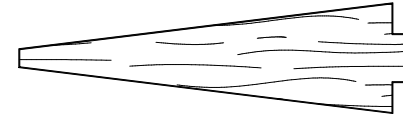

9

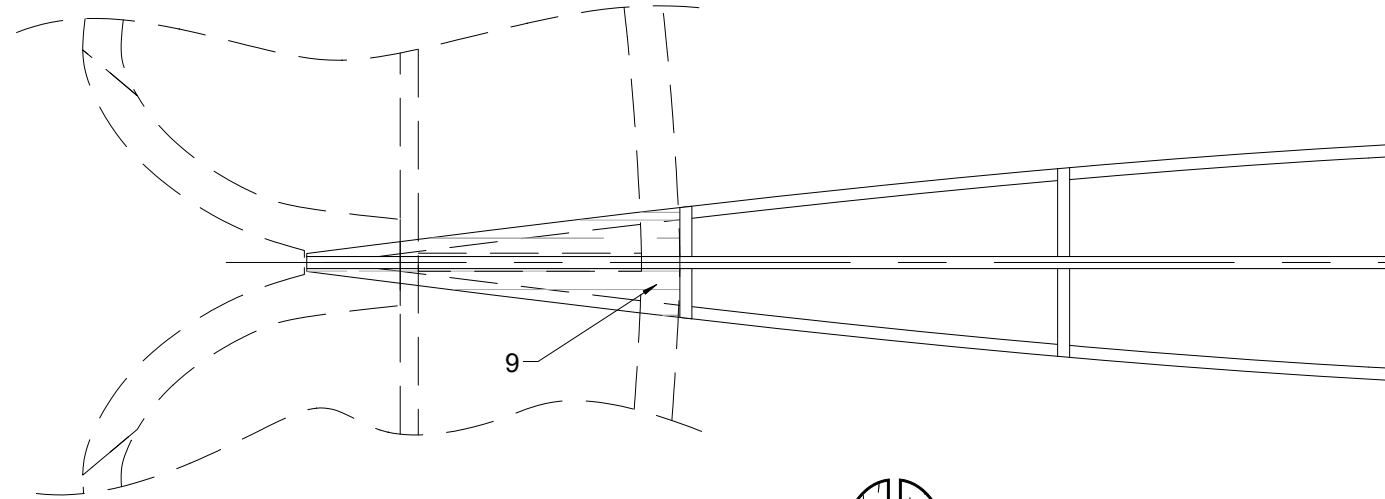

9

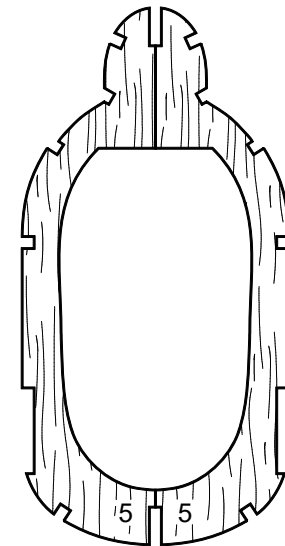
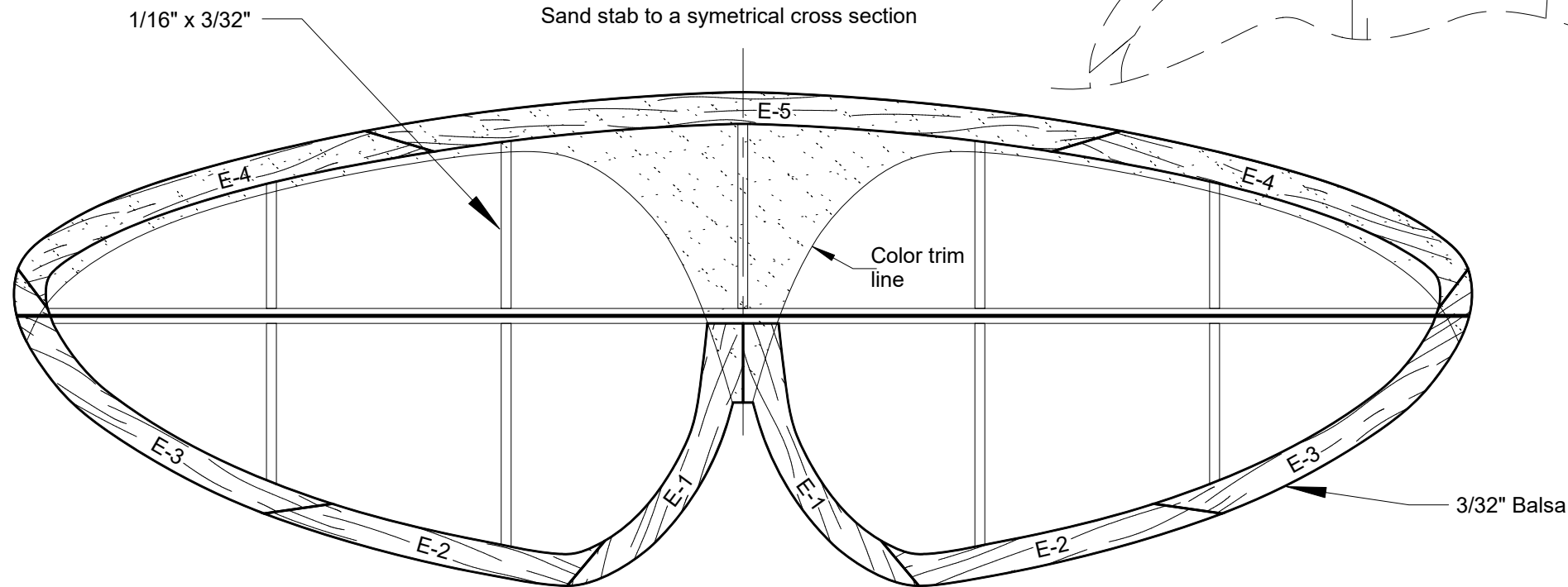

5

5





Pilot Platform
1/16" balsa

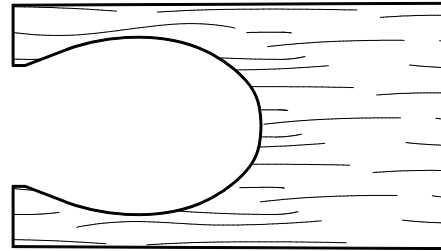

Cockpit Faring
1/32" balsa

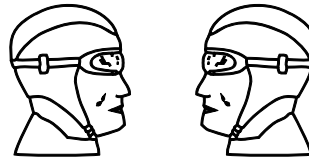

Pilot Profile

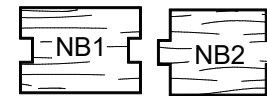
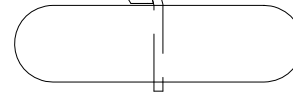
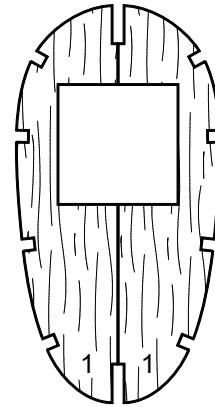
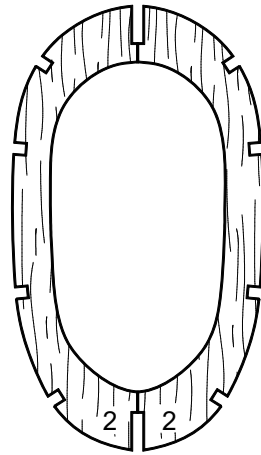
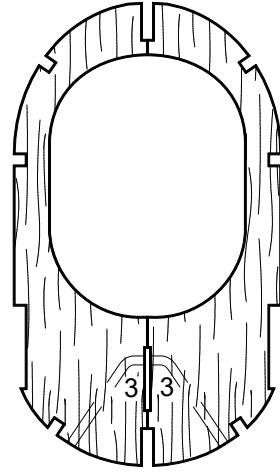
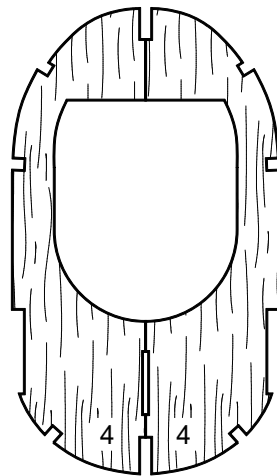
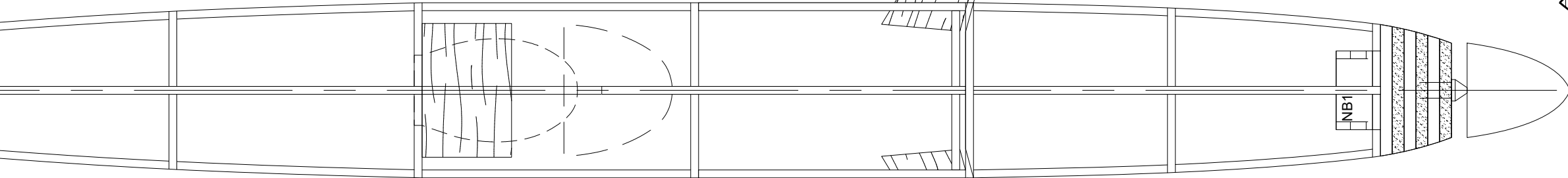
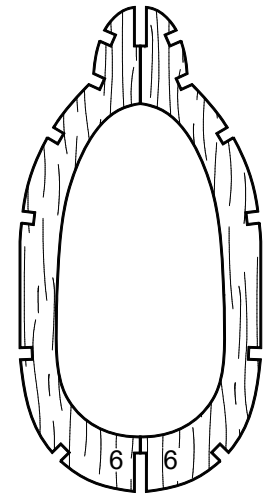
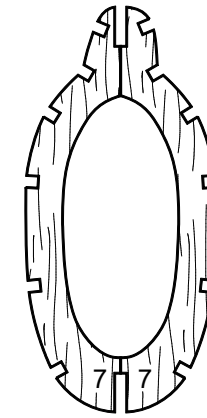
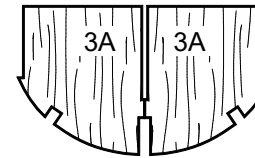
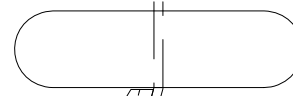

Nose block pieces -
make 2 each from
1/16" balsa

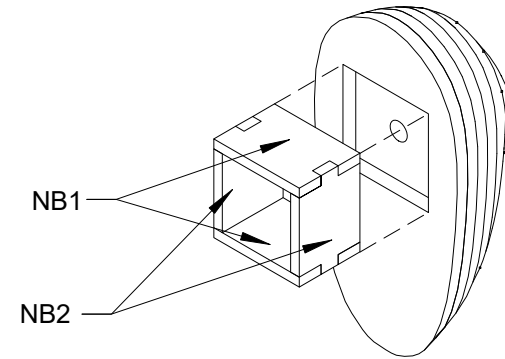

Nose block
arrangement

0 1 2 3 4 5 6

INCHES

Comet Senior Dart

Wingspan - 24"

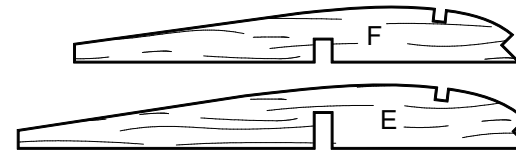
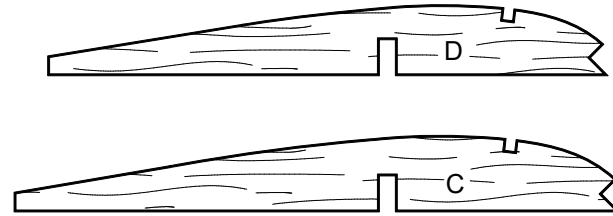
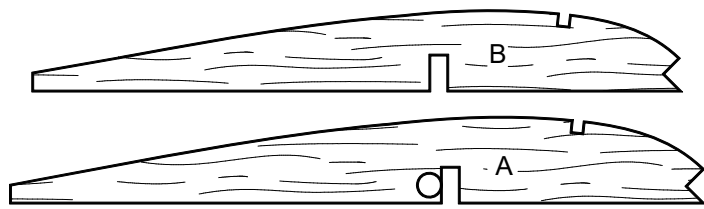

Wing ribs are 1/16" balsa - Make 2 each

1/8" Square

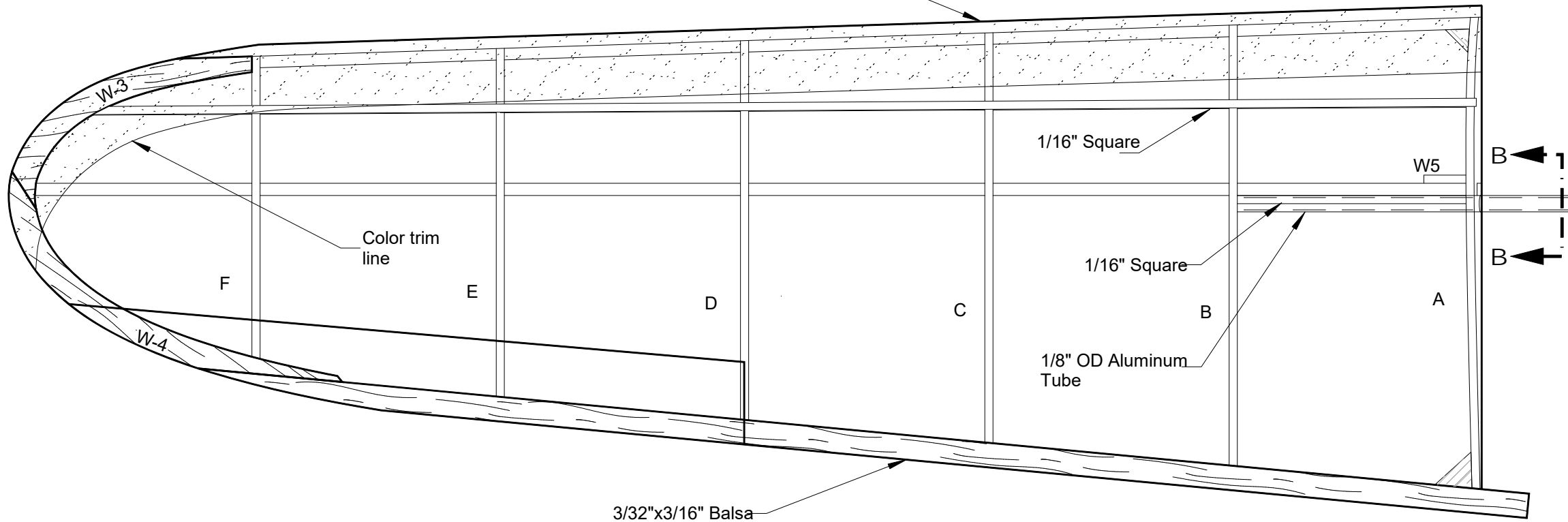

View B-B

Comet Senior Dart

Wingspan - 24"

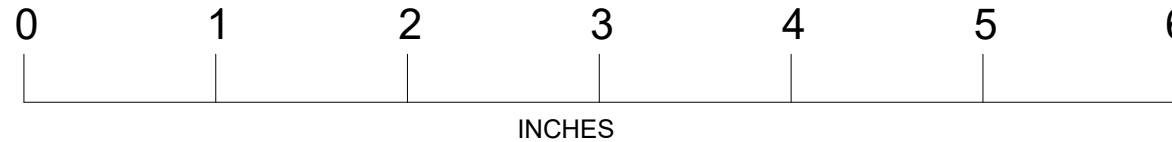

INCHES

Main Spar - 3/16" x 3/32" balsa

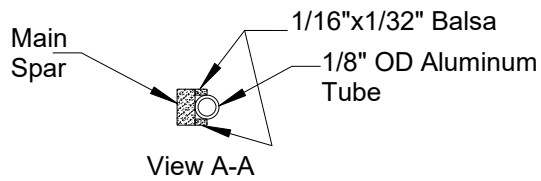
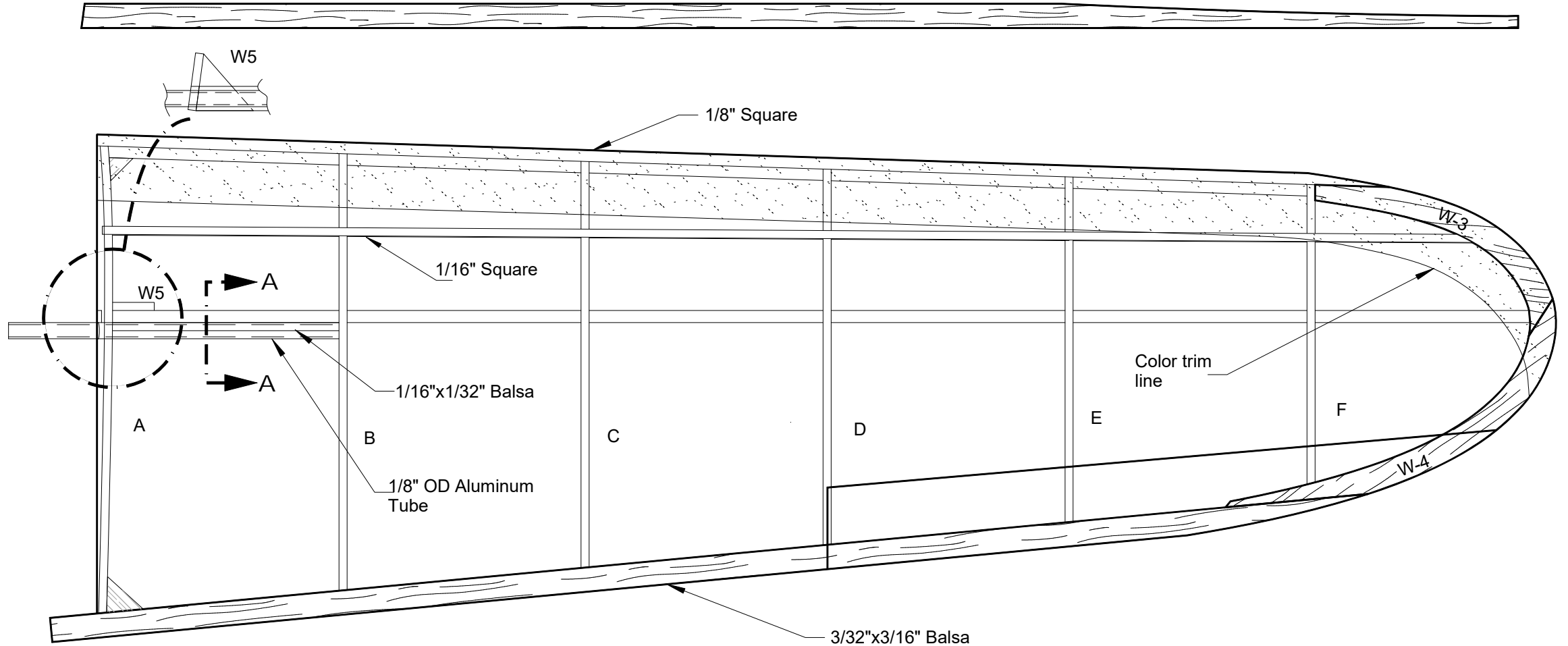

NOTE: A .1" x 1/8" round magnet is placed in the end of each aluminum wing tube. Make sure the magnets are oriented to attract each other. Drill the tube end for the magnet.

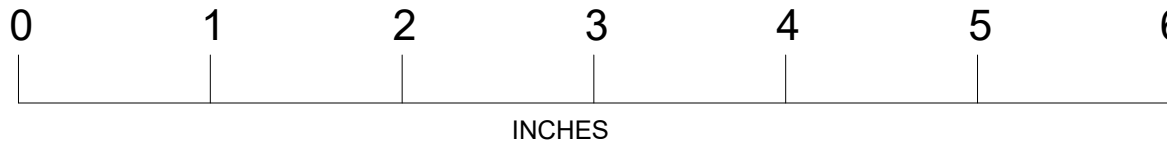

Comet Senior Dart

Wingspan - 24"