

This E20 motor mount is set up to allow easy adjustments to the motor thrust line. It accepts the E20 class 8520 motors. It has been designed to fit 4 mm diameter carbon tube fuselages.

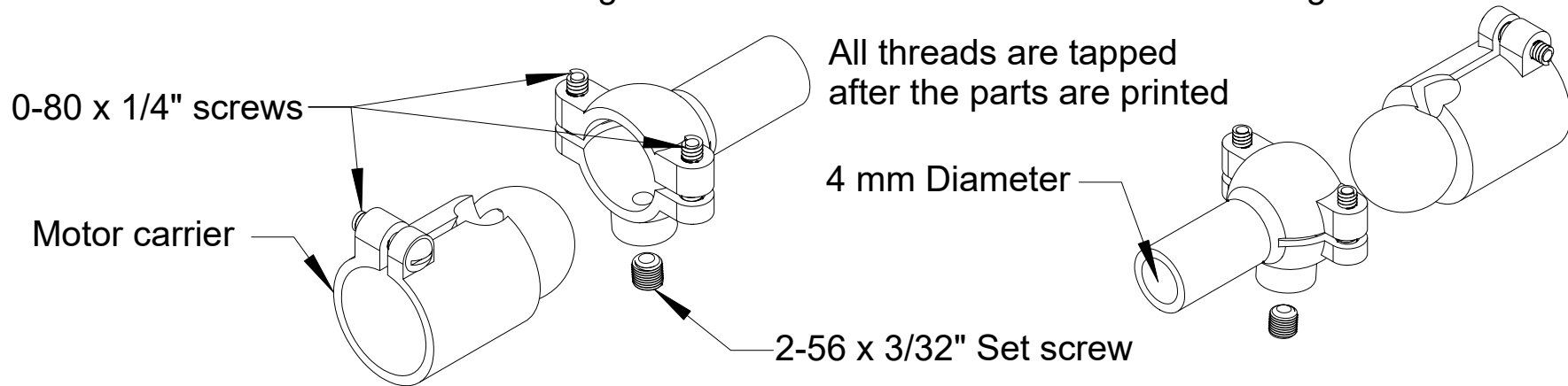

In addition to the mount, a magnetic prop brake is also included. Its use is optional but has proven to be very effective in preventing the prop from free wheeling during the glide phase of a flight. Measurements have been made for a given motor and prop combination with and without the brake installed. The performance difference was found to be only 150 RPM.

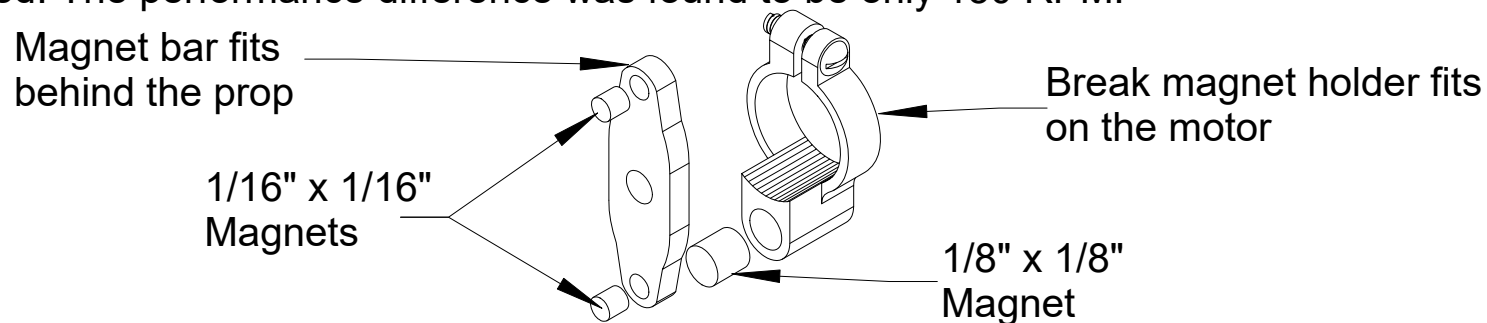

While not necessary, it has been found that using a prop adapter on the motor can make the use of the magnetic brake easier to set up. It also makes the overall installation of the prop much easier. The prop adapter being used is made from a DuBro threaded pushrod coupler for 1/16" diameter pushrods.

