

LO 'N SLO

Designed by Bill Welle

Wing Span - 60"
Wing Area - 715 Square Inches
Flying Weight - 24 to 26 ounces
Wing Loading - 4.8 to 5.2 oz/ft
Wing Cubed Loading - 2.2 to 2.4

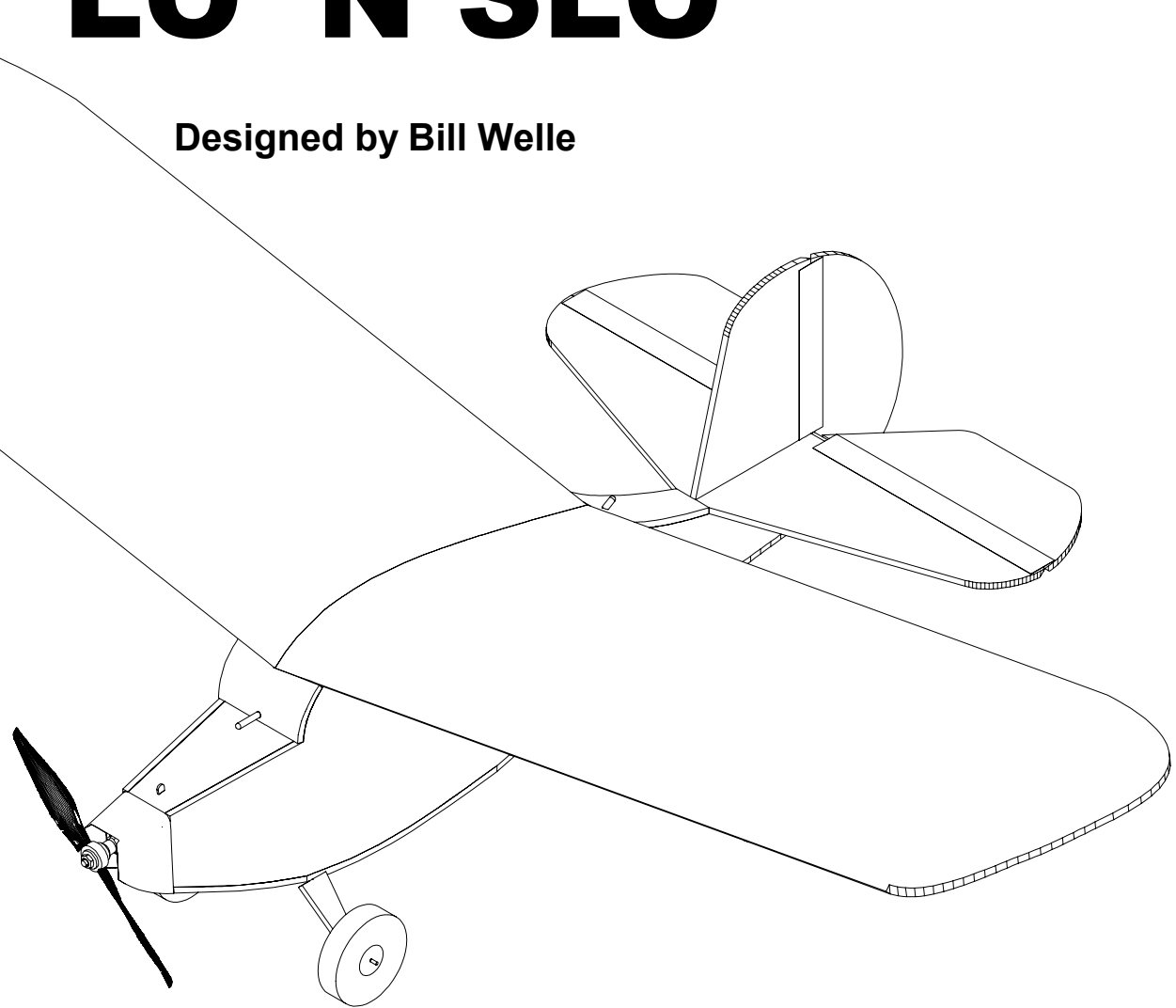

ASSEMBLY GUIDE

Plan and Assembly Guide by Paul Bradley

1.

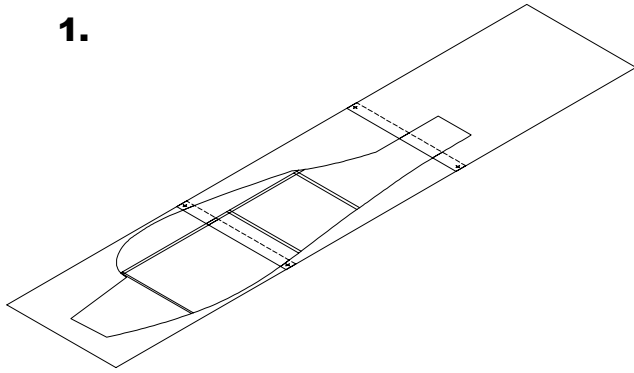

Assembly begins by taping the part sheets that are larger than a single printed page together. The groups that go together are marked with the group name and sheet x of y.

2.

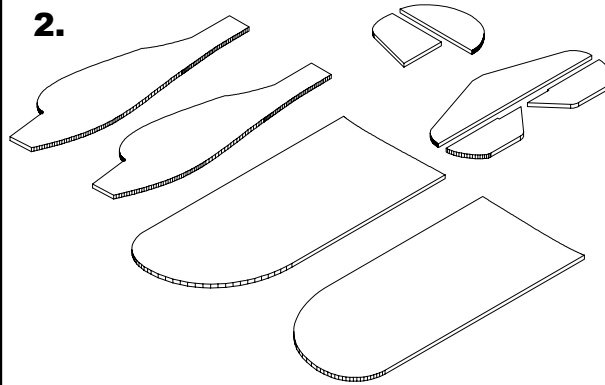

Cut out all of the parts. Note the parts that are to be cut from plywood rather than foam board.

3.

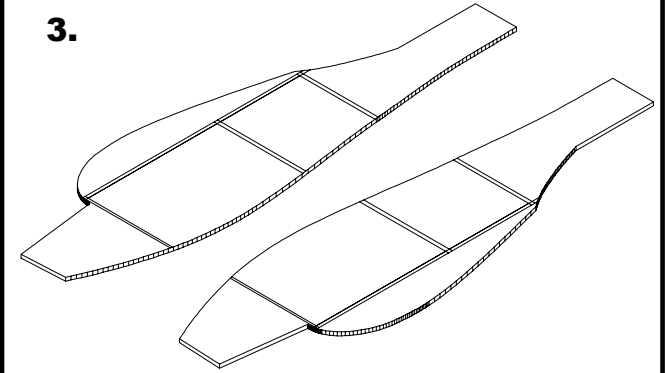

Using the fuselage side template, draw the template reference lines on each fuselage side. Be sure to make a left and right side.

4.

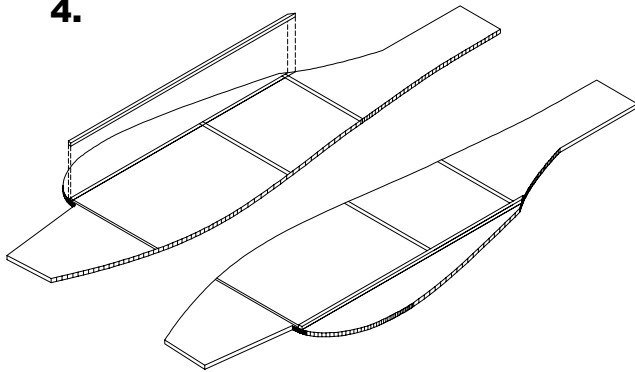

Glue 3/16" square balsa strips to the fuselage sides as shown. Use the reference lines as a location guide.

5.

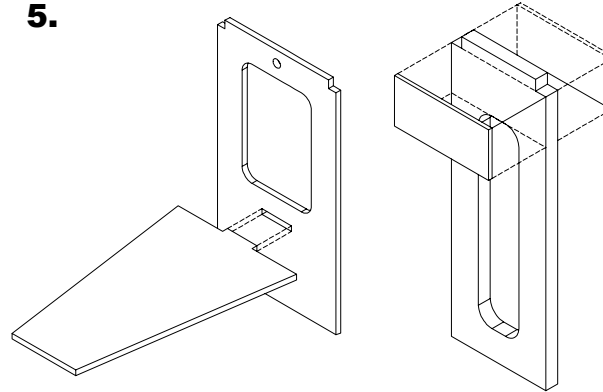

Glue the Liteply battery tray to the Liteply fuselage former F2 as shown. The angle between the two pieces should be 90 degrees. Also glue the 1/16" plywood doublers to the top of F4.

6.

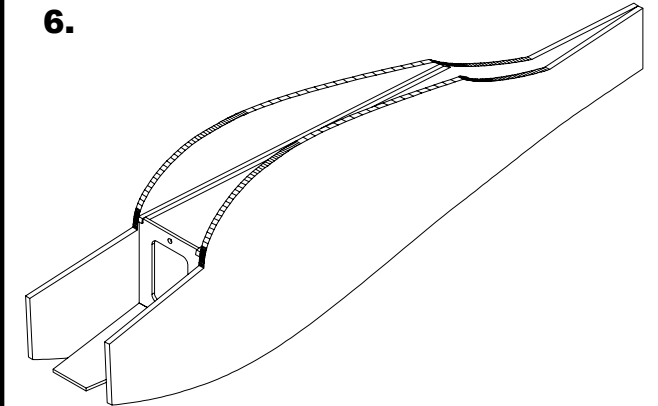

Glue the Liteply fuselage former F2 to each fuselage side as shown. Also glue the rear fuselage joint. The battery tray faces forward.

7.

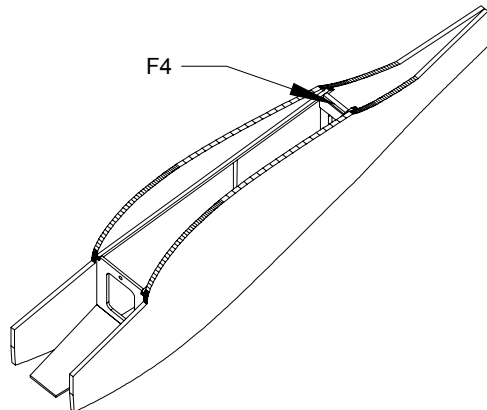

Glue fuselage former F4 in place. Use the drawn reference lines as a location guide.

8.

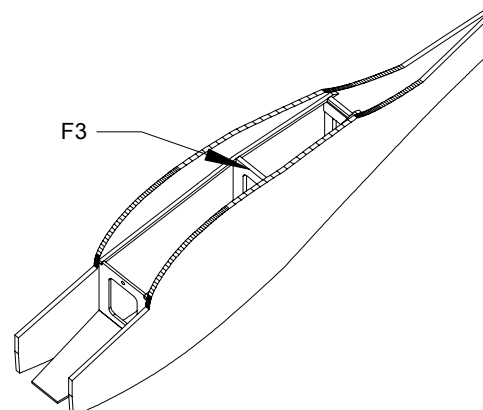

Glue fuselage former F3 in place. Again, use the drawn reference lines as a location guide.

9.

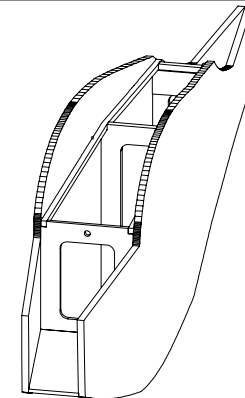

When the glue on formers F3 and F4 as fully set, pull the sides together at the nose so they are in contact with the battery tray. Glue the sides to the tray.

10.

Mark both sides

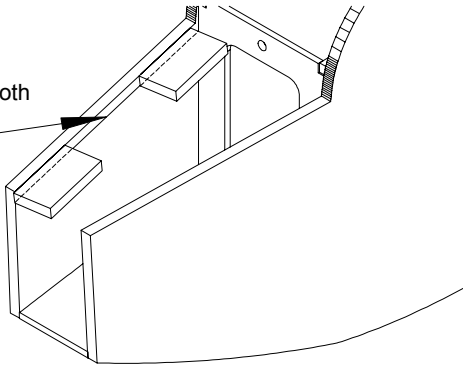

Use a scrap piece of the foam board to mark the depth of the battery hatch on the inside face of each fuselage side as shown.

11.

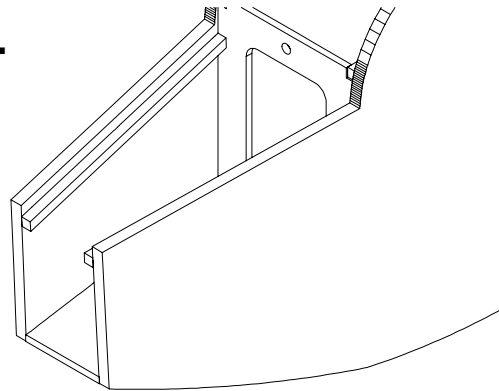

Using the marks as a location guide, glue 3/16" square strips of balsa to the inside face of each fuselage side as shown. These strips form the supports for the battery hatch.

12.

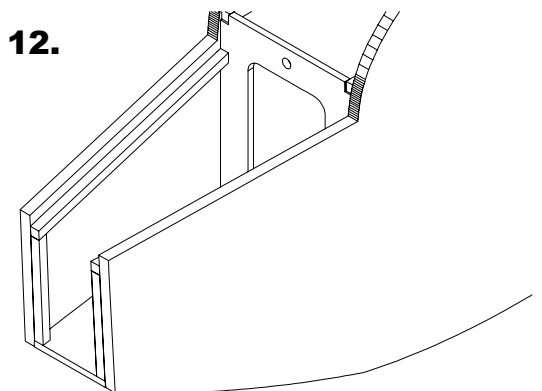

Glue a piece of 3/16" square balsa strip to the inside face of the nose of each fuselage side. The pieces fit between the battery tray and battery hatch supports.

13.

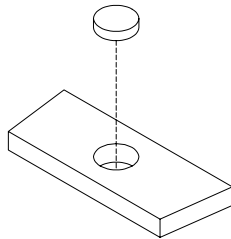

Glue a 1/4" x 1/16" magnet in the hole of F6. The magnet should be flush with one side of F6. Orientation of the magnet does not matter.

14.

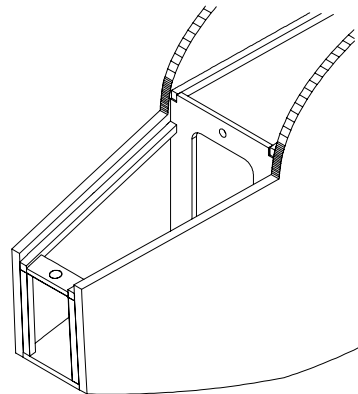

Orient F6 so the magnet is facing up. Glue F6 to the balsa hatch supports as shown. It lines up with the bottom edge of the supports. Carefully sand the nose so everything is flush with the sides.

15.

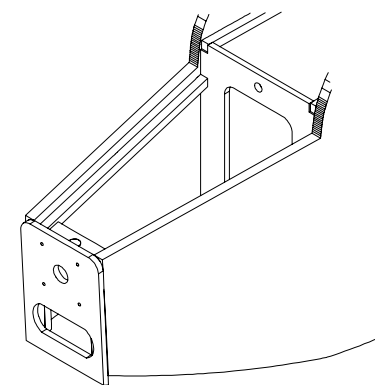

Mark the screw holes for the motor mount of your chosen motor on the 1/8" LitePly former F1. Drill pilot holes for the screws. Now glue the F1 to the nose of the fuselage as shown.

16.

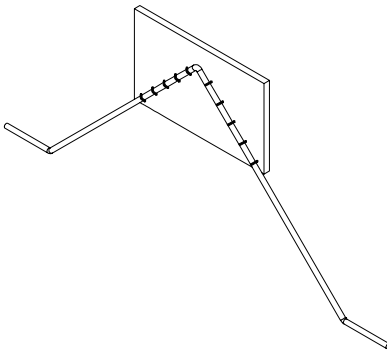

Make up the landing gear legs from 3/32" piano wire using the provided pattern. Bind the landing gear legs to F2A. The provided template shows the suggested location and associated 1/32" diameter holes to use with the binding material.

17.

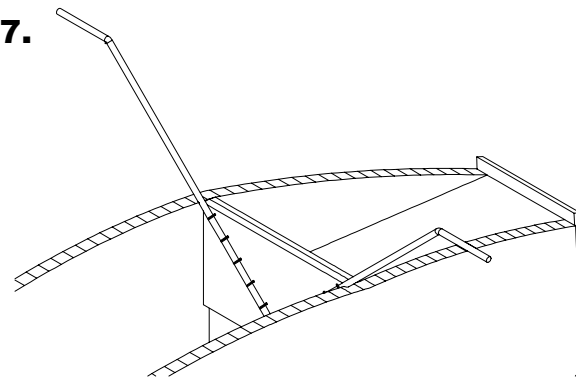

Glue F2A with the attached landing gear legs to the back side of F2. Line up the bottom with the bottom of F2.

18.

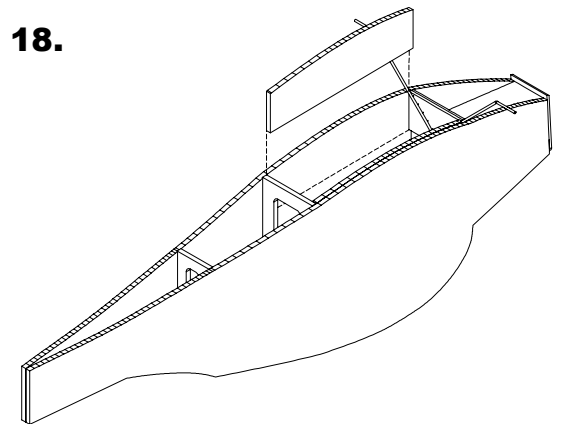

Glue the receiver/servo tray supports to the fuselage sides. They fit between F2A and F3.

19.

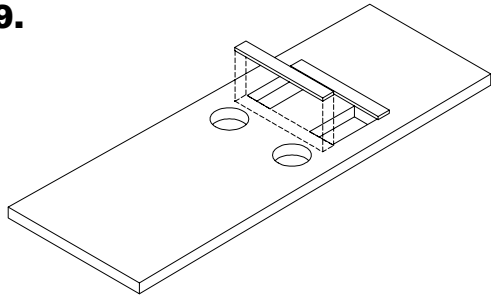

Glue some 1/16" plywood cut into 1/4" wide strips, or some 1/16" x 1/4" Bass wood to create hard points on the fore and aft edges of the servo cut outs in the receiver/servo tray. Mount the servos on the tray. Route the servo leads through the round holes in the tray.

20.

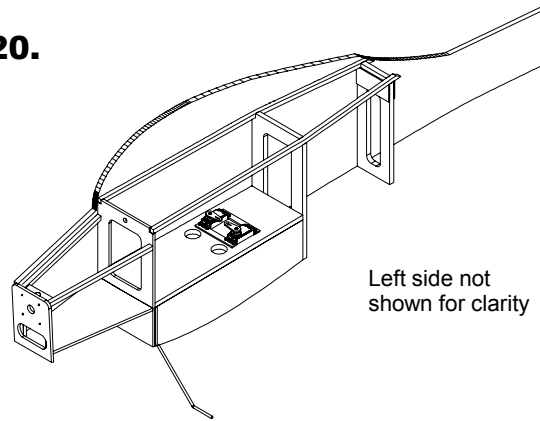

Left side not shown for clarity

Glue the receiver/servo tray to the top edge of the tray supports.

21.

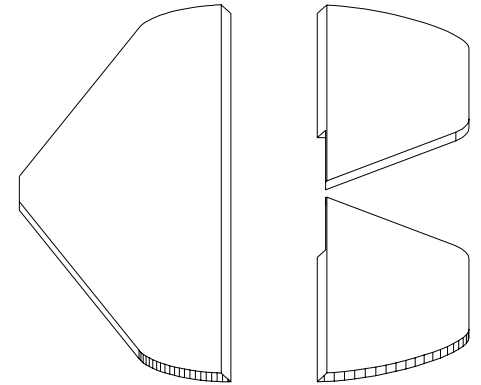

Sand the trailing edge of the stab so it is beveled as shown on the plan. Also sand the elevator leading edges to a bevel as shown on the plan.

22.

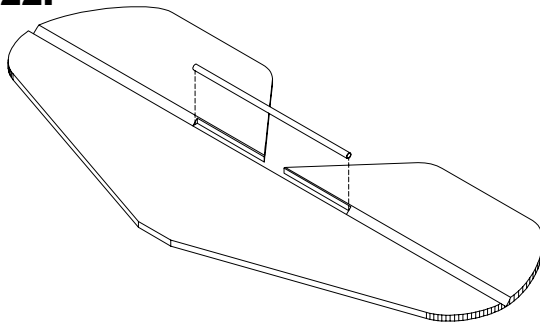

Cut a length of 3/16" aluminum tubing to a length of 6 1/2". Rough the surface with some sand paper. Lay the elevators next to the stab. Using epoxy, glue the aluminum tube jointer to the elevator halves. Remove the stab before the epoxy sets.

23.

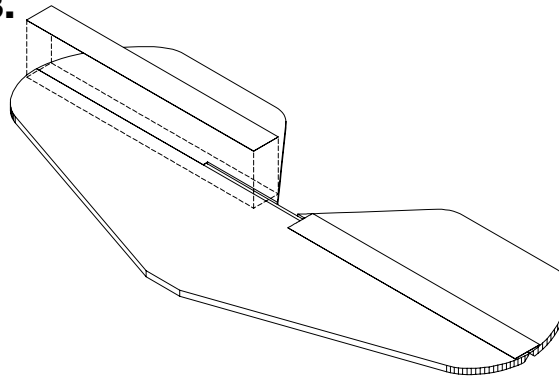

Cut some 1" wide strips of clear packing tape. Use the strips to attach the elevators to the stab.

24.

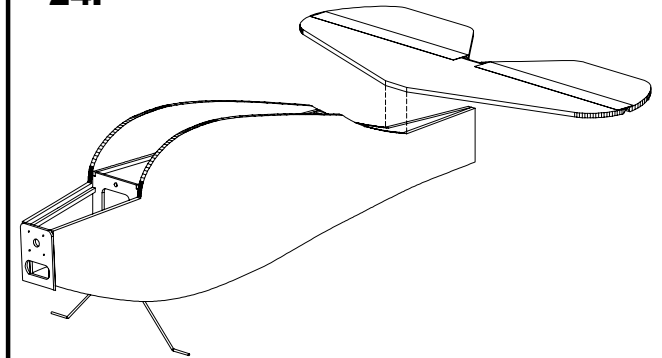

Glue the stab assembly to the fuselage as shown. Make sure it is square to the fuselage sides.

25.

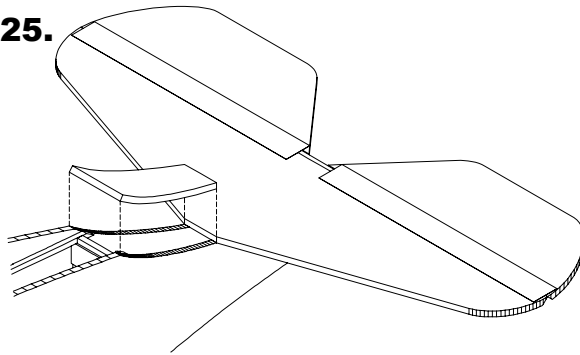

Glue the top rear fuselage piece to the fuselage assembly. Some pre-bending will help with this step. It may be necessary to sand the rear edge of this piece to be vertical.

26.

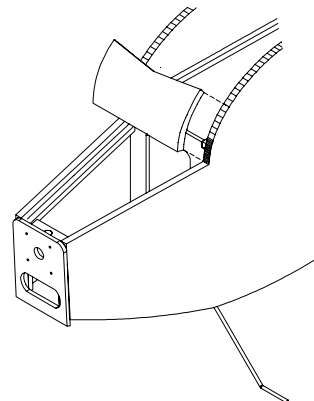

Glue part F5 to the forward edge of the wing mount area as shown.

27.

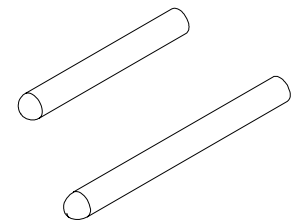

Cut a 1 1/2" and 2" length of dowel. Round off one end of each dowel as shown.

28.

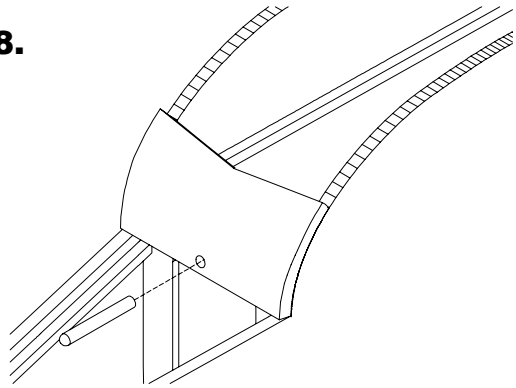

From the back side of F2, use a 3/16" diameter drill to make a hole in F5. Slide the 1 1/2" length of dowel through the hole so it fully engages F2. Glue the dowel to F2.

29.

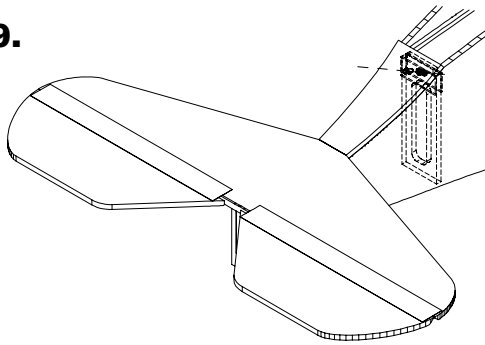

Make a mark 13/16" down from the top edge of the rear fuselage top piece. The mark should be centered on the top piece. Using a 3/16" diameter drill, drill a hole at the mark with the drill about 60 degrees down from vertical. You want to drill through F4 and the 1/16" plywood doublers on the top of F4.

30.

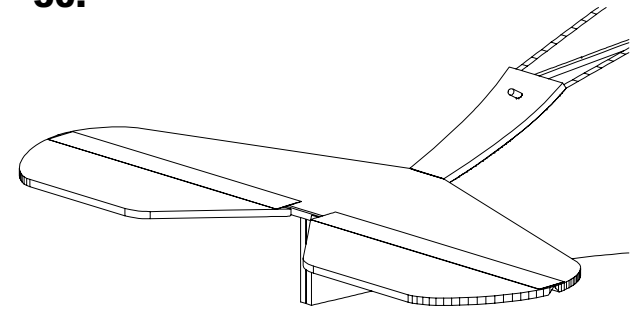

Slide the 2" length of dowel through the hole and also through the hole in the top of F4. Glue the dowel to F4.

31.

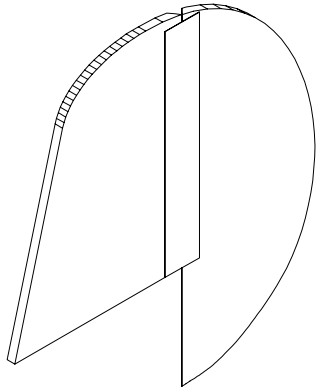

Like the stab and elevators, sand the trailing edge of the fin and leading edge of the rudder to a bevel. Attach the rudder to the fin using a piece of packing tape cut into a 1" wide strip.

32.

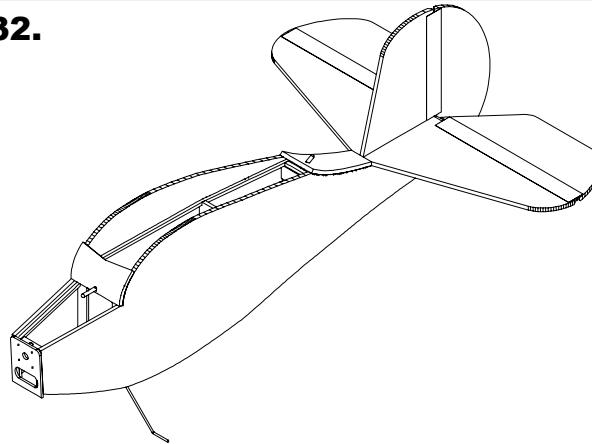

Glue the fin/rudder assembly to the top of the stab.

33.

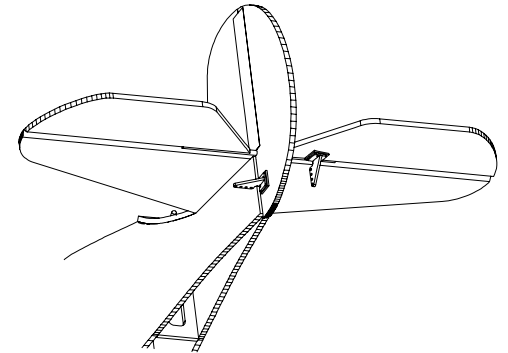

Install the rudder and elevator control horns. Use 1/16" plywood pads under the horns and locking plate. Determine the push rod routing for your specific servo installaton. Cut holes/slots in the fuselage sides for the pushrods. Install the pushrods. Use supports for the pushrods.

34.

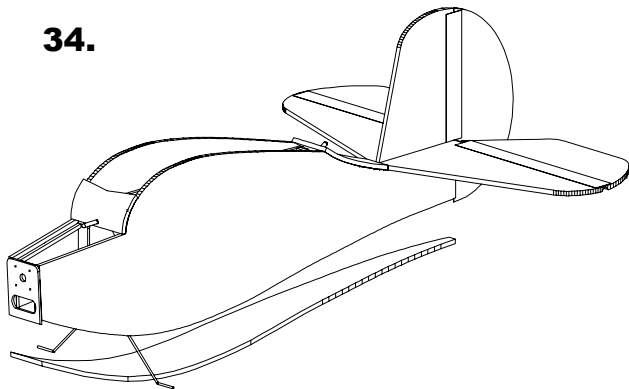

Glue the fuselage bottom to the fuselage assembly. Some pre-bending to conform to the shape will make this step easier to complete.

35.

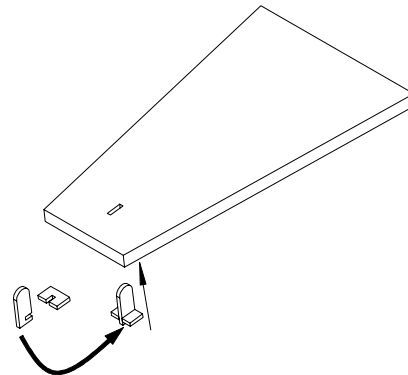

Assemble the 1/16" plywood hatch pull parts. Slide the hatch pull through the hole in the hatch from the bottom and glue it in place.

36.

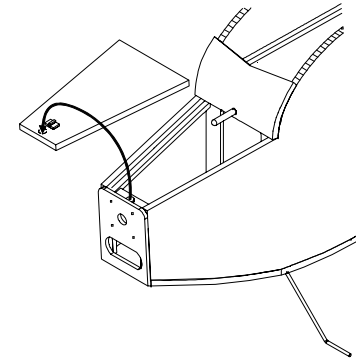

Place a 1/4" x 1/16" magnet on top of the magnet in the forward hatch support. Use a marker to mark the face of the magnet. Place the hatch on the model. Some marker ink will transfer to the hatch. Remove the hatch and glue the magnet in place with the marked face toward the bottom of the hatch.

37.

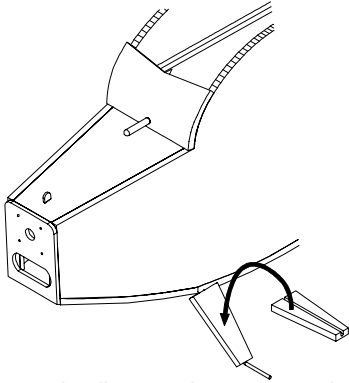

If desired, mount landing gear leg covers to the landing gear legs. Cut a slot in the back side of each over and then glue them to the legs with epoxy. Allow some clearance at the top between the fuselage sides for flexing of the legs.

38.

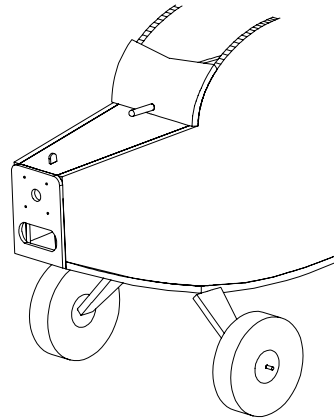

Mount 3" diameter lite wheels on the landing gear legs using 3/32" wheel collars.

39.

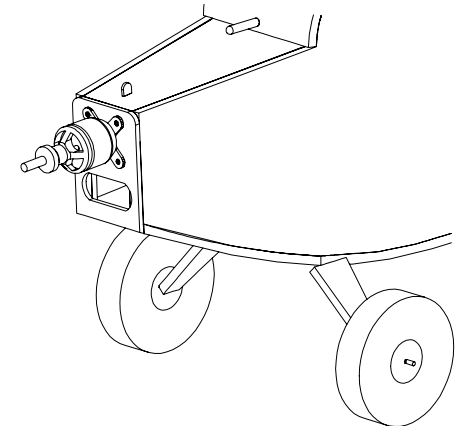

Mount the motor to the firewall. This is a good time to also mount the ESC and receiver.

40.

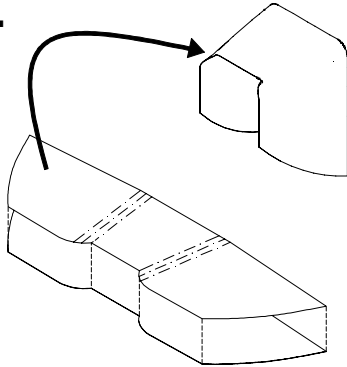

Cut the cowl from aluminum drink can stock using the supplied template. A good way to do this is to rubber cement the template to the aluminum sheet stock. Use the bend lines on the template to bend the cowl to the shape of F1.

41.

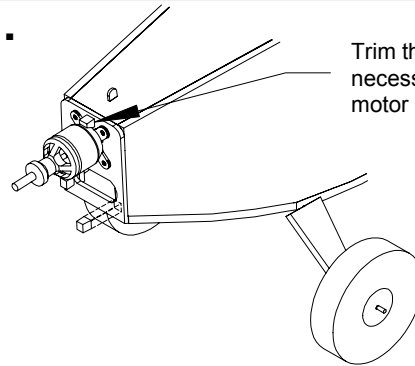

Trim the top block if necessary to clear the motor

The cowl is retained with three pad pairs of hook and loop fastener material (Velcro). Cut three 1/4"x1/4"x1/4" balsa blocks. Measure the thickness of your hook and loop material when both halves are pressed together. Glue the blocks to F1 offset from the edges by the measured thickness.

42.

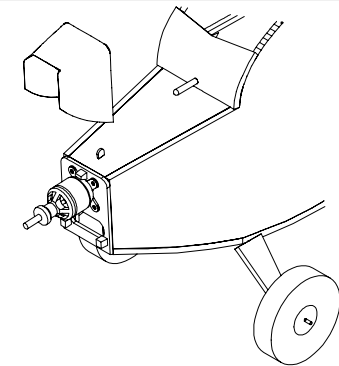

Glue 1/4" square pads of the hook and loop material to the outside face of each block. Glue 1/4" square pads of the opposite side of the hook and loop material to the inside face of the cowl at the block locations. Mount the cowl. It fits over the edge of F1.

43.

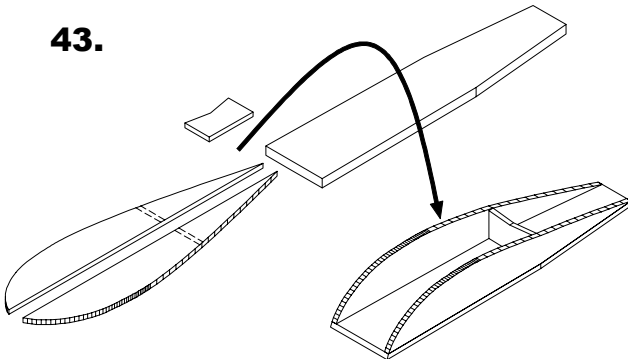

Mark each rib W1 with the location of CS1 using the printed template as a guide. Assemble the center section base structure as shown. Glue the ribs W1 to the top side of the base piece. Sand the leading edge of the base piece to match the rib profile.

44.

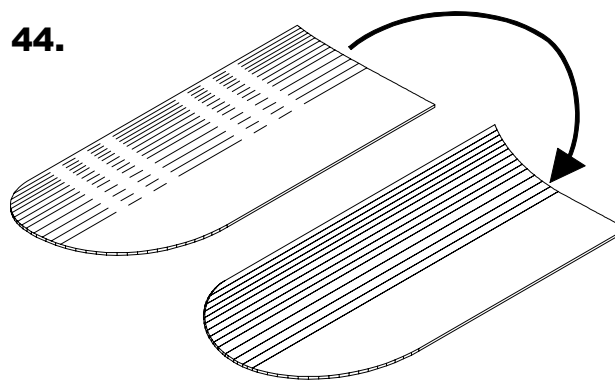

Use the crease lines on the wing panel template to bend the wing panels slightly at each crease line. A yard stick or something similar can be used when bending the panels. This pre-forms each wing panel to the approximate airfoil profile.

45.

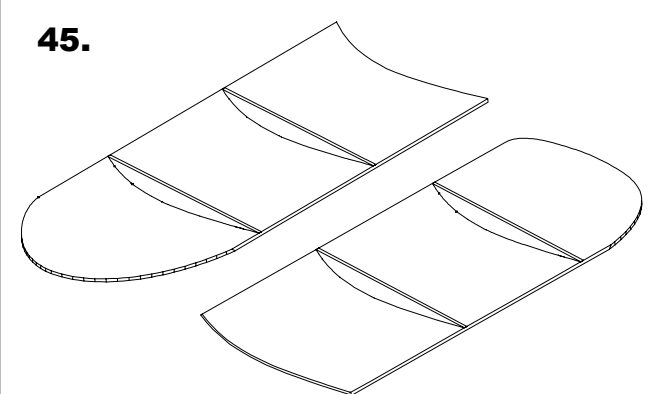

Glue ribs W2 to the wing panels. Use the reference lines on the wing panel template as a location guide.

46.

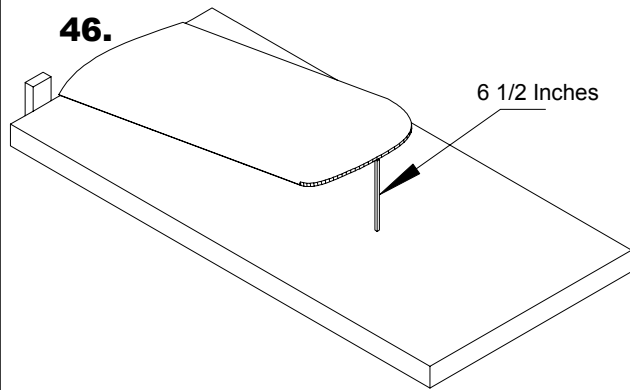

Place each wing panel at the edge of the work surface. Raise the tip 6 1/2 inches from the surface. Sand the root face of each panel so they are vertical.

47.

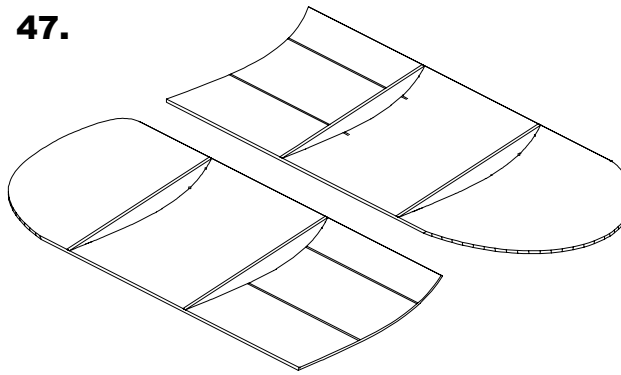

Mark the location of the bamboo skewer reinforcements on each wing panel. Note that the skewers on the right panel should touch the inside faces of the left panel skewers.

48.

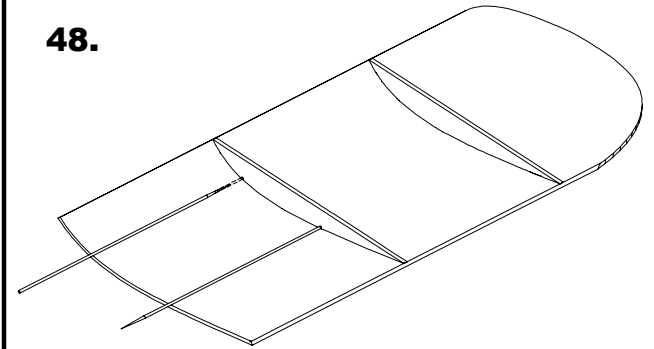

One end of each skewer has a sharp point. Use the pointed end to push the skewer through the first W2 rib. Remove the skewer and turn it around. Re-insert the skewer in the hole of W2 using the blunt end this time. Glue the skewer to the wing panel. Repeat the process for all of the reinforcement skewers.

49.

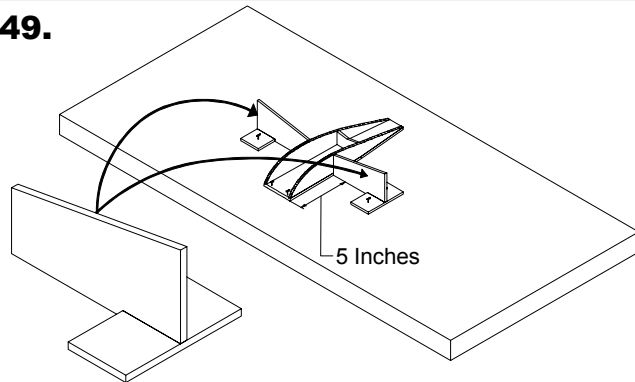

Assemble the two dihedral jigs. Pin the wing center section assembly to the building surface. Pin each dihedral jig to the building surface so they are touching the center section assembly 5" from the forward edge as shown.

50.

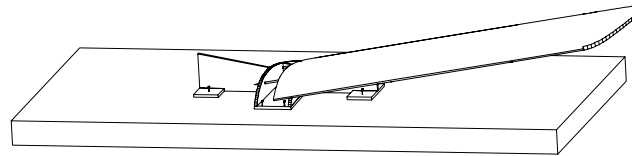

Slide the left wing panel along the dihedral jig until the ends of the skewers contact the W1 center section rib. Push the wing panel far enough to have the skewers pierce the W1. Push the panel until the root edge is centered over the center section assembly. Glue the wing panel and skewers to the center section assembly.

51.

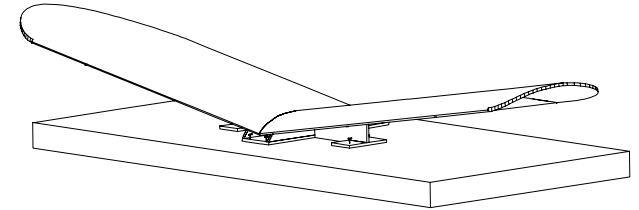

Use the same procedure as in step 50 for the right wing panel. Apply glue to the center joint before it is closed as the wing panel slides into position. Glue the wing panel and skewers to the center section assembly.

52.

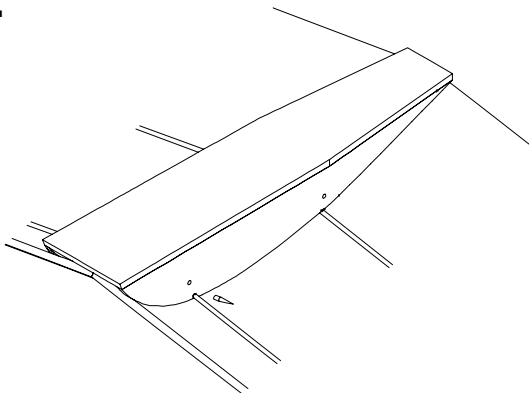

Trim off the excess skewer lengths on each side of the center section assembly.

53.

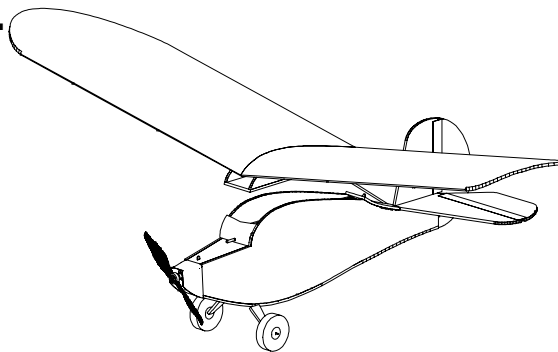

The wing assembly fits inside the fuselage sides behind fuselage part F5. Use several rubber bands to retain the wing assembly. The rubber bands are looped around the two dowels.

54.

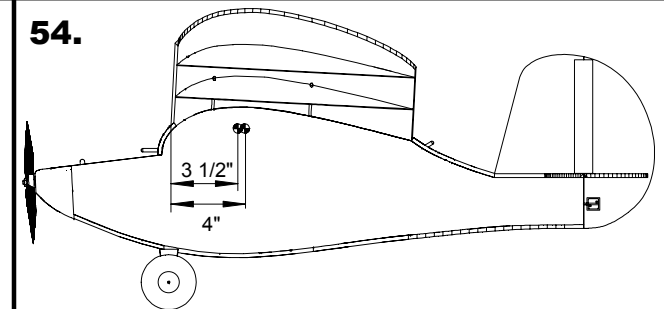

With your flight battery pack in place, check the Center of Gravity (CG) location. It should be in the range of 3 1/2 to 4 inches back from the wing leading edge. Your Lo 'N Slo is now ready for flight. Control throws are not critical.