

DK-LOK

Fittings & Valves

DK-Lok UHP Fittings

No.09-01(E)
May 2017





Safe Component Selection

The selection of component for any applications or system design must be considered to ensure safe performance. Component function, material compatibility, component ratings, proper installation, operation and maintenance remain the sole responsibility of the system designer and the user. DK-Lok accepts no liability for any improper selection, installation, operation or maintenance.

Clean Weld Fittings

Micro Elbow
WML 05



Micro Tee
WMT 05



Micro Cross Tee
WMX 05



Micro Tribow
WMTB 06



Micro Half Elbow
WMHL 06



Micro Reducing Elbow
WMRL 06



Micro Reducing Tee
WMRT 07



Micro Reducer
WMR 07



Long Elbow
WL 08



Long Tee
WT 08



Long Reducing Tee
WRT 08



Long Cross Tee
WX 09



Long Reducer
WR 09



Auto Butt Weld Long Elbow
WLA 09



Auto Butt Weld Long Tee
WTA 10



Auto Butt Weld Long Cross Tee
WXA 10



Auto Butt Weld Long Reducing Tee
WRTA 10



Auto Butt Weld Union
WUA 11



Auto Butt Weld Reducing Union
WRUA 11



Metal Gasket Face-Seal Fittings

Short Gland
SG 13



Long Gland
LG 13



Auto Butt Weld Short Gland
SGA 14



Auto Butt Weld Long Gland
LGA 14



Male Gland
GM 15



Socket Weld Long Gland
GSL 15



Socket Weld Reducing Long Gland
GSR 15



Socket Weld Short Gland
GSS 16



Tube Adapter Gland
GT 16



Blind Gland
BG 16



Female Nut
FN 16



Male Nut
MN 17



Cap
CP 17



Plug
PG 17



Gasket
GK 18



Gasket Retainer GKT		18	Union Elbow L		22	High Flow Female Nut HFN		26
Gasket Blind GKB		18	Union Tee T		22	High Flow Male Nut HMN		26
Double Male Union MU		19	Union Cross Tee X		23	Tube Fitting to Auto Butt Weld Connector DATW		26
Double Male Reducing Union MRU		19	Male NPT Elbow ML-N		23	Welded Assembly Fittings		
Bulkhead Union BHU		19	Coupling C		23	Swivel Female/Male Union SFMU		27
Tube Fitting Connector DC		20	High Flow Fittings			Swivel Female Union SFU		27
Tube Fitting Bulkhead Connector DBHC		20	High Flow Gland HG		24	Swivel Male NPT Connector SMC-N		27
Male NPT Connector MC-N		20	High Flow Reducer HR		24	Swivel Female NPT Connector SFC-N		28
Female NPT Connector FC-N		21	Auto Butt Weld High Flow Reducer HRA		24	Swivel Tube Fitting Connector SDC		28
Bulkhead Male NPT Connector BHMC-N		21	High Flow Bulkhead Reducer HBR		25	Swivel Elbow SL		28
Tube Butt Weld Bulkhead Connector BHTW		21	High Flow Union Elbow HL		25	Swivel Tee ST		29
Straight Thread O-Ring Seal Male Connector MC-UO		22	High Flow Union Tee HT		25			

Ordering Information

DK-Lok Weld Fittings and Metal Face Seal Fittings are ordered by product code shown below.

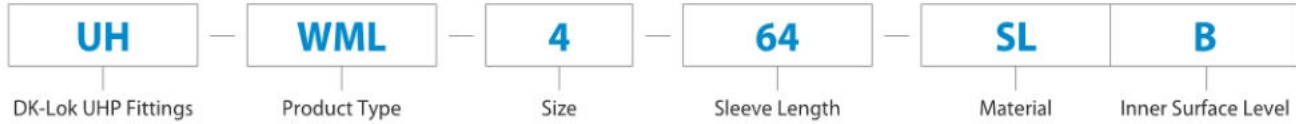

Size	Sleeve Length	Material	Inner Surface Level
4 : 1/4"	64 : 6.4mm	SL : 316L Stainless Steel	B : BA
6 : 3/8"	91 : 9.1mm	DL : 316L Stainless Steel VAR	P : EP
8 : 1/2"	96 : 9.6mm		
12 : 3/4"	191 : 19.1mm		
16 : 1"	244 : 24.4mm		

Product Type			
Micro Fittings		Face Seal Fittings	
WML	Micro 90° Elbow	FN	Female Nut
WMT	Micro Tee	MN	Male Nut
WMX	Micro Cross Tee	CP	Cap
WMTB	Micro Tribow	PG	Plug
WMHL	Micro 45° Elbow	GK	Gasket
WMRL	Micro Reducing Elbow	GKT	Gasket Retainer
WMRT	Micro Reducing Tee	GKB	Gasket Blind
WMR	Micro Reducer	MU	Double Male Union
Tube Butt Weld Fittings		BHU	Bulkhead Union
WL	Long Elbow	DC	DK-Lok Tube Fitting Connector
WRL	Long Reducing Elbow	DBHC	DK-Lok Bulkhead Tube Fitting Connector
WT	Long Tee	MC-N	Male NPT Connector
WRT	Long Reducing Tee	FC-N	Female NPT Connector
WX	Long Cross Tee	BHMC-N	Bulkhead Male NPT Connector
WR	Long Reducer	BHTW	TBW Bulkhead Connector
Face Seal Fittings		MC-UO	O-ring Seal Male Connector
SG	Female Gland	L	Union Elbow
LG	Male Gland	T	Union Tee
SGA	Automatic Female Gland	X	Union Cross Tee
LGA	Automatic Male Gland	C	Coupling
GM	Male Weld Gland	HG	High Flow Gland
GSL	Socket Weld Long Gland	HR	High Flow Reducer
GSR	Socket Weld Reducing Long Gland	HRA	Automatic High Flow Reducer
GSS	Socket Weld Short Gland	HFN	High Flow Female Nut
GT	Tube Adapter Gland	HMN	High Flow Male Nut
BG	Blind Gland	DATW	Tube Fitting to Auto Butt Weld Connector

Pressure Rating

The pressure ratings provided in this catalogue are obtained by the calculation with the allowable stress of 20,000 psig (1,378 bar) of stainless steel 316 at -20°F (-28°C) to 100°F (37°C) according to ASME B31.3 and B31.1 code.

Pressure derating factors are driven by temperatures greater than 100°F (37°C). They are determined from these pressure code listed in the table 1 and in accordance with ASME B31.3 and B31.1 code. Multiply the applicable pressure rating in this catalogue by the factor in the table 1 to determine the working pressure.

Table 1. Derating Factor

Material	SS 316	SS 316L
Temperature °F (°C)	Derating Factor	
-20 (-28) ~ 100 (37)	1.00	1.00
~ 200 (93)	1.00	0.83
~ 400 (204)	0.96	0.77
~ 600 (315)	0.85	0.67
~ 800 (426)	0.79	0.62
~ 1000 (537)	0.76	0.56

Material

Material	Designation	Specification	
		Bar stock	Forging
316L Stainless Steel	SL	ASME SA479	ASME SA182
316L Stainless Steel VAR	DL	ASTM A479/A276	ASME A182

Cleaning & Packing

Passivation is done in accordance with ASTM A380, Ultra-sonic cleaning in a class 100 clean room environment, implemented with resistivity over 18MΩ D.I water after finishing the passivation for precision cleaning. After cleaning, the product receives double packaging in a clean room environment using anti-static polyethylene bags and high purity nitrogen inclusion.

Surface Roughness

Grade	Designation	Surface Level	
BA	B	R_a : 10 µin	R_y : 3.0 µm
EP	P	R_a : 5 µin	R_y : 0.7 µm

Feature

- Accommodates the miniature tubing system
- Allows close parts spacing
- Flow capacity to be equivalent to the conventional big size welding fitting

Rounded Edge : all edges of the product are rounded for safe handling and to help prevent damage the other products

Material Heat code : marked on the product for easy raw material traceability

Laser Marking : shows the manufacturer, material / grade, heat code and process number on the body for easy identification

10 µin. R_a and 5 µin. R_a are standard surface finish

Sharp and burr-free tube end :

Radiused Junction : pockets and entrapment zones in the junction portion are eliminated for a smooth flow transition

For automatic tube butt welding, integral filler ring is provided for proper alignment

Accurately machined diameter dimension conforms to tube diameter



For Tees, the run (1 to 2) shall precede the branch(3)

For Crosses, the run (1 to 2) shall precede the branch(3 to 4)

Clean Weld Fittings

Micro Elbow

WML

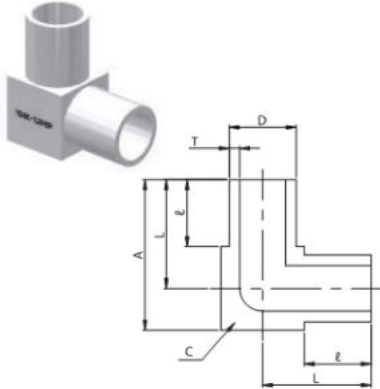

Tube Size (D)	Part No.	Thickness (Tube Wall)		L		ℓ		A		C Body Cube	Working Pressure psig(bar)
		in.	mm	in.	mm	in.	mm	in.	mm		
1/8	UH-WML-2	0.028	0.7	0.41	10.4	0.25	6.4	0.56	14.40	5/16	8500(585)
1/4	UH-WML-4	0.035	0.8	0.41	10.4	0.25	6.4	0.56	14.40	5/16	5100(351)
3/8	UH-WML-6	0.035	0.8	0.47	11.9	0.25	6.4	0.69	17.40	7/16	3300(227)
1/2	UH-WML-8	0.049	1.24	0.53	13.5	0.25	6.4	0.81	20.60	9/16	3700(254)
Metric	Part No.	mm		in.	mm	in.	mm	in.	mm	in.	psig(bar)
6M	UH-WML-6M	1.0		0.41	10.4	0.25	6.4	0.56	14.40	5/16	6100(420)
8M	UH-WML-8M	1.0		0.47	11.9	0.25	6.4	0.69	17.40	7/16	4500(310)
10M	UH-WML-10M	1.0		0.47	11.9	0.25	6.4	0.69	17.40	7/16	3500(240)
12M	UH-WML-12M	1.0		0.53	13.5	0.25	6.4	0.81	20.60	9/16	2900(200)

Micro Tee

WMT

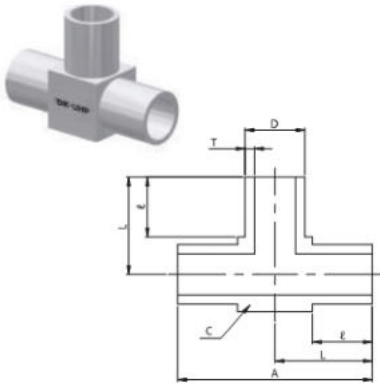

Tube Size (D)	Part No.	Thickness (Tube Wall)		L		ℓ		A		C Body Cube	Working Pressure psig(bar)
		in.	mm	in.	mm	in.	mm	in.	mm		
1/8	UH-WMT-2	0.028	0.7	0.41	10.4	0.25	6.4	0.82	20.80	5/16	8500(585)
1/4	UH-WMT-4	0.035	0.8	0.41	10.4	0.25	6.4	0.82	20.80	5/16	5100(351)
3/8	UH-WMT-6	0.035	0.8	0.47	11.9	0.25	6.4	0.94	23.80	7/16	3300(227)
1/2	UH-WMT-8	0.049	1.24	0.53	13.5	0.25	6.4	1.06	27.00	9/16	3700(254)
Metric	Part No.	mm		in.	mm	in.	mm	in.	mm	in.	psig(bar)
6M	UH-WMT-6M	1.0		0.41	10.4	0.25	6.4	0.82	20.80	5/16	6100(420)
8M	UH-WMT-8M	1.0		0.47	11.9	0.25	6.4	0.94	23.80	7/16	4500(310)
10M	UH-WMT-10M	1.0		0.47	11.9	0.25	6.4	0.94	23.80	7/16	3500(240)
12M	UH-WMT-12M	1.0		0.53	13.5	0.25	6.4	1.06	27.00	9/16	2900(200)

Micro Cross Tee

WMX

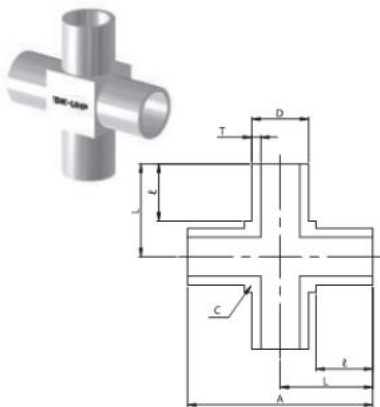

Tube Size (D)	Part No.	Thickness (Tube Wall)		L		ℓ		A		C Body Cube	Working Pressure psig(bar)
		in.	mm	in.	mm	in.	mm	in.	mm		
1/8	UH-WMX-2	0.028	0.7	0.41	10.4	0.25	6.4	0.82	20.80	5/16	8500(585)
1/4	UH-WMX-4	0.035	0.8	0.41	10.4	0.25	6.4	0.82	20.80	5/16	5100(351)
3/8	UH-WMX-6	0.035	0.8	0.47	11.9	0.25	6.4	0.94	23.80	7/16	3300(227)
1/2	UH-WMX-8	0.049	1.24	0.53	13.5	0.25	6.4	1.06	27.00	9/16	3700(254)
Metric	Part No.	mm		in.	mm	in.	mm	in.	mm	in.	psig(bar)
6M	UH-WMX-6M	1.0		0.41	10.4	0.25	6.4	0.82	20.80	5/16	6100(420)
8M	UH-WMX-8M	1.0		0.47	11.9	0.25	6.4	0.94	23.80	7/16	4500(310)
10M	UH-WMX-10M	1.0		0.47	11.9	0.25	6.4	0.94	23.80	7/16	3500(240)
12M	UH-WMX-12M	1.0		0.53	13.5	0.25	6.4	1.06	27.00	9/16	2900(200)

Micro Tribow

WMTB

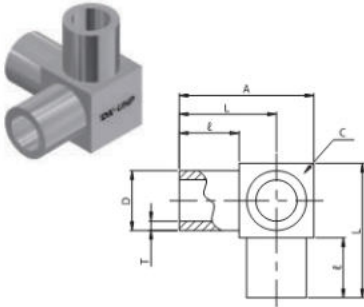

Tube Size (D)	Part No.	Thickness (Tube Wall)		L		ℓ		A		C Body Cube	Working Pressure
		in.	mm	in.	mm	in.	mm	in.	mm		
1/4	UH-WMTB-4	0.035	0.8	0.41	10.4	0.25	6.4	0.56	14.4	5/16	5100(351)
3/8	UH-WMTB-6	0.035	0.8	0.47	11.9	0.25	6.4	0.69	17.4	7/16	3300(227)
1/2	UH-WMTB-8	0.049	1.24	0.53	13.5	0.25	6.4	0.81	20.6	9/16	3700(254)

Micro Half Elbow

WMHL

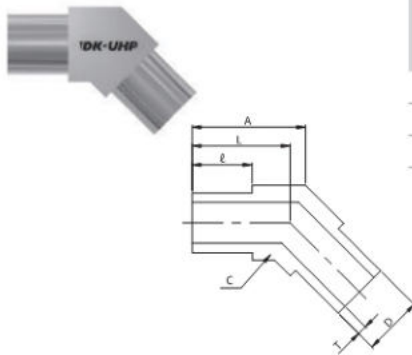

Tube Size (D)	Part No.	Thickness (Tube Wall)		L		ℓ		A		C Body Cube	Working Pressure
		in.	mm	in.	mm	in.	mm	in.	mm		
1/4	UH-WMHL-4	0.035	0.8	0.41	10.4	0.25	6.4	0.47	12.0	5/16	5100(351)
3/8	UH-WMHL-6	0.035	0.8	0.47	11.9	0.25	6.4	0.56	14.2	7/16	3300(227)
1/2	UH-WMHL-8	0.049	1.24	0.53	13.5	0.25	6.4	0.64	16.46	9/16	3700(254)

Micro Reducing Elbow

WMRL

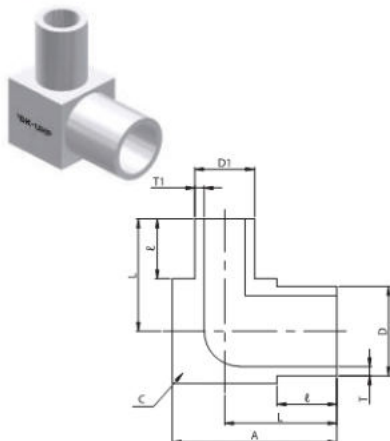

Size (D)	Size (D1)	Part No.	Thickness(Wall) T		Thickness(Wall) T1		L		ℓ		A		C Body Cube	Working Pressure
			in.	mm	in.	mm	in.	mm	in.	mm	in.	mm		
3/8	1/4	UH-WMRL-6X4	0.035	0.8	0.035	0.8	0.47	11.9	0.25	6.4	0.69	17.4	7/16	3300(227)
1/2	1/4	UH-WMRL-8X4	0.049	1.24	0.035	0.8	0.53	13.5	0.25	6.4	0.81	20.6	9/16	3700(254)
1/2	3/8	UH-WMRL-8X6	0.049	1.24	0.035	0.8	0.53	13.5	0.25	6.4	0.81	20.6	9/16	3300(227)
Metric		Part No.	mm		mm		in.		mm		in.		mm	psig(bar)
8M	6M	UH-WMRL-8MX6M	1.0		1.0		0.47		11.9		0.25		6.4	4500(310)
10M	6M	UH-WMRL-10MX6M	1.0		1.0		0.47		11.9		0.25		6.4	3500(240)
12M	6M	UH-WMRL-12MX6M	1.0		1.0		0.53		13.5		0.25		6.4	2900(200)
12M	8M	UH-WMRL-12MX8M	1.0		1.0		0.53		13.5		0.25		6.4	2900(200)

Micro Reducing Tee

WMRT

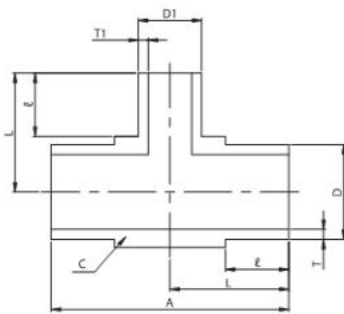

Size (D)	Size (D1)	Part No.	Thickness(Wall) T		Thickness(Wall) T1		L		ℓ		A		C Body Cube	Working Pressure
			in.	mm	in.	mm	in.	mm	in.	mm	in.	mm		
3/8	1/4	UH-WMRT-6X4	0.035	0.8	0.035	0.8	0.47	11.9	0.25	6.4	0.94	23.8	7/16	3300(227)
1/2	1/4	UH-WMRT-8X4	0.049	1.24	0.035	0.8	0.53	13.5	0.25	6.4	1.06	27	9/16	3700(254)
1/2	3/8	UH-WMRT-8X6	0.049	1.24	0.035	0.8	0.53	13.5	0.25	6.4	1.06	27	9/16	3300(227)
Metric		Part No.	mm		mm		in.	mm	in.	mm	in.	mm	in.	mm
8M	6M	UH-WMRT-8MX6M	1.0		1.0		0.47	11.9	0.25	6.4	0.94	23.8	7/16	4500(310)
10M	6M	UH-WMRT-10MX6M	1.0		1.0		0.47	11.9	0.25	6.4	0.94	23.8	7/16	3500(240)
12M	6M	UH-WMRT-12MX6M	1.0		1.0		0.53	13.5	0.25	6.4	1.06	27	9/16	2900(200)
12M	8M	UH-WMRT-12MX8M	1.0		1.0		0.53	13.5	0.25	6.4	1.06	27	9/16	2900(200)

Micro Reducer

WMR

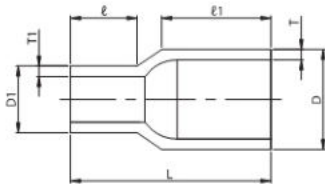

Size (D)	Size (D1)	Part No.	Thickness(Wall) T		Thickness(Wall) T1		L		ℓ		ℓ1		Working Pressure
			in.	mm	in.	mm	in.	mm	in.	mm	in.	mm	
1/4	1/8	UH-WMR-4X2	0.035	0.8	0.028	0.7	0.75	19.1	0.25	6.4	0.41	10.7	5100(351)
3/8	1/4	UH-WMR-6X4	0.035	0.8	0.035	0.8	0.75	19.1	0.25	6.4	0.41	10.7	3300(227)
1/2	1/4	UH-WMR-8X4	0.049	1.24	0.035	0.8	0.75	19.1	0.25	6.4	0.41	10.7	3700(254)
1/2	3/8	UH-WMR-8X6	0.049	1.24	0.035	0.8	0.75	19.1	0.25	6.4	0.41	10.7	3300(227)
Metric		Part No.	mm		mm		in.	mm	in.	mm	in.	mm	mm
8M	6M	UH-WMR-8MX6M	1.0		1.0		0.75	19.1	0.25	6.4	0.41	10.7	4500(310)
10M	6M	UH-WMR-10MX6M	1.0		1.0		0.75	19.1	0.25	6.4	0.41	10.7	3500(240)
12M	6M	UH-WMR-12MX6M	1.0		1.0		0.75	19.1	0.25	6.4	0.41	10.7	2900(200)
12M	8M	UH-WMR-12MX8M	1.0		1.0		0.75	19.1	0.25	6.4	0.41	10.7	2900(200)

Long Elbow

WL

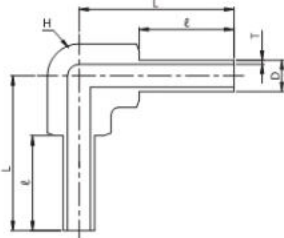

Tube Size (D)	Part No.	Thickness (Tube Wall)		L		e		H Body Cube	Working Pressure
		in.	mm	in.	mm	in.	mm		
1/4	UH-WL-4-191	0.035	0.8	1.23	31.2	0.75	19.1	7/16	5100(351)
3/8	UH-WL-6-191	0.035	0.8	1.20	30.5	0.75	19.1	7/16	3300(227)
1/2	UH-WL-8-191	0.049	1.2	1.34	34.0	0.75	19.1	11/16	3700(254)
3/4	UH-WL-12-191	0.049	1.2	1.46	37.1	0.75	19.1	15/16	2400(165)
1	UH-WL-16-244	0.065	1.6	1.85	47.0	0.94	24.4	1 1/4	2400(165)
Metric	Part No.	mm		in.	mm	in.	mm	in.	psig(bar)
6M	UH-WL-6M-191	1.0		1.23	31.2	0.75	19.1	7/16	6100(420)
8M	UH-WL-8M-191	1.0		1.23	31.2	0.75	19.1	7/16	4500(310)
10M	UH-WL-10M-191	1.0		1.34	34.0	0.75	19.1	11/16	3500(240)
12M	UH-WL-12M-191	1.0		1.34	34.0	0.75	19.1	11/16	2900(200)
18M	UH-WL-18M-191	1.5		1.48	37.6	0.75	19.1	15/16	2900(200)

Long Tee

WT

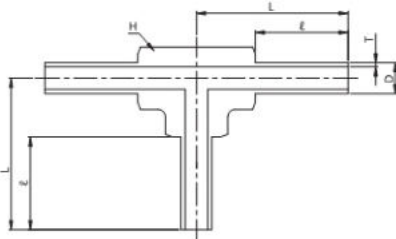

Tube Size (D)	Part No.	Thickness (Tube Wall)		L		e		H Body Cube	Working Pressure
		in.	mm	in.	mm	in.	mm		
1/4	UH-WT-4-191	0.035	0.8	1.23	31.2	0.75	19.1	7/16	5100(351)
3/8	UH-WT-6-191	0.035	0.8	1.20	30.5	0.75	19.1	7/16	3300(227)
1/2	UH-WT-8-191	0.049	1.2	1.34	34.0	0.75	19.1	11/16	3700(254)
3/4	UH-WT-12-191	0.049	1.2	1.46	37.1	0.75	19.1	15/16	2400(165)
1	UH-WT-16-244	0.065	1.6	1.85	47.0	0.94	24.4	1 1/4	2400(165)
Metric	Part No.	mm		in.	mm	in.	mm	in.	psig(bar)
6M	UH-WT-6M-191	1.0		1.23	31.2	0.75	19.1	7/16	6100(420)
8M	UH-WT-8M-191	1.0		1.23	31.2	0.75	19.1	7/16	4500(310)
10M	UH-WT-10M-191	1.0		1.34	34.0	0.75	19.1	11/16	3500(240)
12M	UH-WT-12M-191	1.0		1.34	34.0	0.75	19.1	11/16	2900(200)
18M	UH-WT-18M-191	1.5		1.48	37.6	0.75	19.1	15/16	2900(200)

Long Reducing Tee

WRT

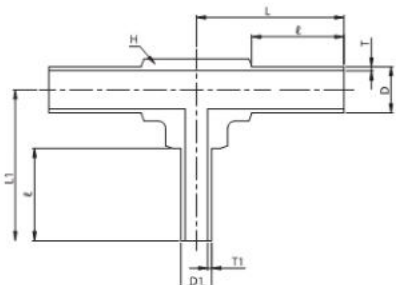

Size (D)	Size (D1)	Part No.	Thickness(Wall) T		Thickness(Wall) T1		L		L1		e		H Body Cube	Working Pressure
			in.	mm	in.	mm	in.	mm	in.	mm	in.	mm		
3/8	1/4	UH-WRT-6X4-191	0.035	0.8	0.035	0.8	1.20	30.5	1.23	31.2	0.75	19.1	7/16	3300(227)
1/2	1/4	UH-WRT-8X4-191	0.049	1.2	0.035	0.8	1.34	34.0	1.34	34.0	0.75	19.1	11/16	3700(254)
1/2	3/8	UH-WRT-8X6-191	0.049	1.2	0.035	0.8	1.34	34.0	1.35	34.3	0.75	19.1	11/16	3300(227)
3/4	1/4	UH-WRT-12X4-191	0.049	1.2	0.035	0.8	1.46	37.1	1.48	37.6	0.75	19.1	15/16	2400(165)
3/4	3/8	UH-WRT-12X6-191	0.049	1.2	0.035	0.8	1.46	37.1	1.48	37.6	0.75	19.1	15/16	2400(165)
Metric	Part No.	mm		mm		in.	mm	in.	mm	in.	mm	in.	mm	psig(bar)
8M	6M	UH-WRT-8MX6M-191		1.0		1.23	31.2	1.23	31.2	0.75	19.1	7/16	4500(310)	
10M	6M	UH-WRT-10MX6M-191		1.0		1.34	34.0	1.34	34.0	0.75	19.1	11/16	3500(240)	
10M	8M	UH-WRT-10MX8M-191		1.0		1.34	34.0	1.34	34.0	0.75	19.1	11/16	2900(200)	
12M	6M	UH-WRT-12MX6M-191		1.0		1.34	34.0	1.34	34.0	0.75	19.1	11/16	2900(200)	
12M	8M	UH-WRT-12MX8M-191		1.0		1.34	34.0	1.34	34.0	0.75	19.1	11/16	2900(200)	

Long Cross Tee

WX

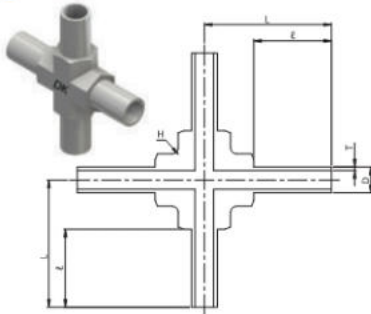

Tube Size (D)	Part No.	Thickness (Tube Wall)		L		e		H Body Cube	Working Pressure
		in.	mm	in.	mm	in.	mm		
1/4	UH-WX-4-191	0.035	0.8	1.23	31.2	0.75	19.1	7/16	5100(351)
3/8	UH-WX-6-191	0.035	0.8	1.20	30.5	0.75	19.1	7/16	3300(227)
1/2	UH-WX-8-191	0.049	1.2	1.31	33.2	0.75	19.1	5/8	3700(254)
Metric	Part No.	mm		in.	mm	in.	mm	in.	psig(bar)
6M	UH-WX-6M-191	1.0		1.23	31.2	0.75	19.1	7/16	6100(420)
8M	UH-WX-8M-191	1.0		1.23	31.2	0.75	19.1	7/16	4500(310)
10M	UH-WX-10M-191	1.0		1.28	32.4	0.75	19.1	5/8	3500(240)
12M	UH-WX-12M-191	1.0		1.28	32.4	0.75	19.1	5/8	2900(200)

Long Reducer

WR

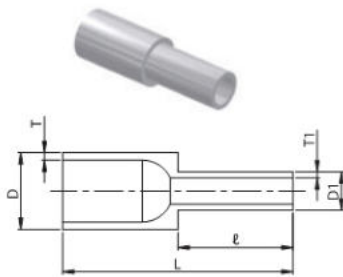

Size (D)	Size (D1)	Part No.	Thickness(Wall) T		Thickness(Wall) T1		L		e		Working Pressure
			in.	mm	in.	mm	in.	mm	in.	mm	
3/8	1/4	UH-WR-6X4-191	0.035	0.8	0.035	0.8	1.5	38.1	0.75	19.1	3300(227)
1/2	1/4	UH-WR-8X4-191	0.049	1.2	0.035	0.8	1.5	38.1	0.75	19.1	3700(254)
1/2	3/8	UH-WR-8X6-191	0.049	1.2	0.035	0.8	1.5	38.1	0.75	19.1	3300(227)
3/4	1/2	UH-WR-12X8-191	0.049	1.2	0.049	1.2	1.5	38.1	0.75	19.1	2400(165)
1	1/2	UH-WR-16X8-191	0.065	1.6	0.049	1.2	1.5	38.1	0.75	19.1	2400(165)
1	3/4	UH-WR-16X12-191	0.065	1.6	0.049	1.2	1.5	38.1	0.75	19.1	2400(165)
Metric	Part No.	mm		mm		in.	mm	in.	mm	psig(bar)	
10M	6M	UH-WR-10MX6M-191		1.0		1.0	1.5	38.1	0.75	19.1	3500(240)
10M	8M	UH-WR-10MX8M-191		1.0		1.0	1.5	38.1	0.75	19.1	3500(240)
12M	6M	UH-WR-12MX6M-191		1.0		1.0	1.5	38.1	0.75	19.1	2900(200)
12M	8M	UH-WR-12MX8M-191		1.0		1.0	1.5	38.1	0.75	19.1	2900(200)
12M	10M	UH-WR-12MX10M-191		1.0		1.0	1.5	38.1	0.75	19.1	2900(200)
18M	6M	UH-WR-18MX6M-191		1.5		1.0	1.5	38.1	0.75	19.1	2900(200)
18M	12M	UH-WR-18MX12M-191		1.5		1.0	1.5	38.1	0.75	19.1	2900(200)

Auto Butt Weld Long Elbow

WLA

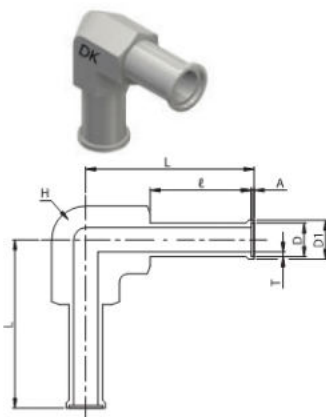

Size (D)	Part No.	Thickness (Tube Wall)		L		e		A		D1		H Body Cube	Working Pressure
		in.	mm	in.	mm	in.	mm	in.	mm	in.	mm		
1/4	UH-WLA-4-191	0.035	0.8	1.25	31.8	0.75	19.1	0.02	0.51	0.29	7.4	7/16	5100(351)
3/8	UH-WLA-6-191	0.035	0.8	1.23	31.2	0.75	19.1	0.03	0.76	0.41	10.4	7/16	3300(227)
1/2	UH-WLA-8-191	0.049	1.2	1.38	35.1	0.75	19.1	0.04	1.0	0.55	14.0	11/16	3700(254)
3/4	UH-WLA-12-191	0.049	1.2	1.50	38.1	0.75	19.1	0.04	1.0	0.80	20.3	15/16	2400(165)
1	UH-WLA-16-244	0.065	1.6	1.89	48.0	0.94	24.4	0.04	1.0	1.06	26.9	1 1/4	2400(165)
Metric	Part No.	mm		in.	mm	in.	mm	in.	mm	in.	mm	in.	psig(bar)
6M	UH-WLA-6M-191	1.0		1.25	31.8	0.75	19.1	0.02	0.51	0.27	6.9	7/16	6100(420)
8M	UH-WLA-8M-191	1.0		1.26	32.0	0.75	19.1	0.03	0.76	0.35	8.9	7/16	4500(310)
10M	UH-WLA-10M-191	1.0		1.37	34.8	0.75	19.1	0.03	0.76	0.43	10.9	11/16	3500(240)
12M	UH-WLA-12M-191	1.0		1.38	35.1	0.75	19.1	0.04	1.0	0.52	13.2	11/16	2900(200)
18M	UH-WLA-18M-191	1.5		1.52	38.6	0.75	19.1	0.04	1.0	0.76	19.3	15/16	2900(200)

Auto Butt Weld Long Tee

WTA

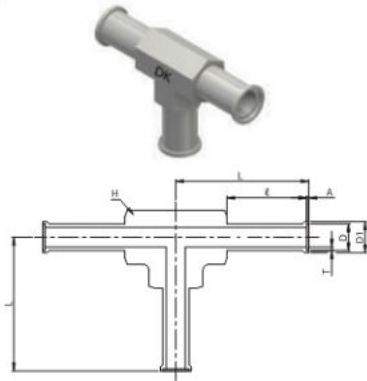

Size (D)	Part No.	Thickness (Tube Wall)		L		ℓ		A		D1		H Body Cube	Working Pressure
		in.	mm	in.	mm	in.	mm	in.	mm	in.	mm		
1/4	UH-WTA-4-191	0.035	0.8	1.25	31.8	0.75	19.1	0.02	0.51	0.29	7.4	7/16	5100(351)
3/8	UH-WTA-6-191	0.035	0.8	1.23	31.2	0.75	19.1	0.03	0.76	0.41	10.4	7/16	3300(227)
1/2	UH-WTA-8-191	0.049	1.2	1.38	35.1	0.75	19.1	0.04	1.0	0.55	14.0	11/16	3700(254)
3/4	UH-WTA-12-191	0.049	1.2	1.50	38.1	0.75	19.1	0.04	1.0	0.80	20.3	15/16	2400(165)
1	UH-WTA-16-244	0.065	1.6	1.89	48.0	0.94	24.4	0.04	1.0	1.06	26.9	1 1/4	2400(165)
Metric	Part No.	mm		in.	mm	in.	mm	in.	mm	in.	mm	in.	psig(bar)
6M	UH-WTA-6M-191	1.0	1.25	31.8	0.75	19.1	0.02	0.51	0.27	6.8	7/16	6100(420)	
8M	UH-WTA-8M-191	1.0	1.26	32.0	0.75	19.1	0.03	0.76	0.35	8.9	7/16	4500(310)	
10M	UH-WTA-10M-191	1.0	1.37	34.8	0.75	19.1	0.03	0.76	0.43	10.9	11/16	3500(240)	
12M	UH-WTA-12M-191	1.0	1.38	35.1	0.75	19.1	0.04	1.0	0.52	13.2	11/16	2900(200)	
18M	UH-WTA-18M-191	1.5	1.52	38.6	0.75	19.1	0.04	1.0	0.76	19.3	15/16	2900(200)	

Auto Butt Weld Long Cross Tee

WXA

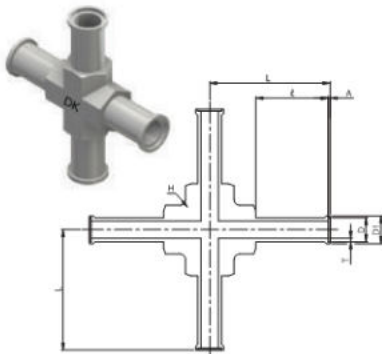

Size (D)	Part No.	Thickness (Tube Wall)		L		ℓ		A		D1		H Body Cube	Working Pressure
		in.	mm	in.	mm	in.	mm	in.	mm	in.	mm		
1/4	UH-WXA-4-191	0.035	0.8	1.25	31.8	0.75	19.1	0.02	0.51	0.29	7.4	7/16	5100(351)
3/8	UH-WXA-6-191	0.035	0.8	1.23	31.2	0.75	19.1	0.03	0.76	0.41	10.4	7/16	3300(227)
1/2	UH-WXA-8-191	0.049	1.2	1.35	34.3	0.75	19.1	0.04	1.0	0.55	14.0	5/8	3700(254)
Metric	Part No.	mm		in.	mm	in.	mm	in.	mm	in.	mm	in.	psig(bar)
6M	UH-WXA-6M-191	1.0	1.25	31.8	0.75	19.1	0.02	0.51	0.27	6.8	7/16	6100(420)	
8M	UH-WXA-8M-191	1.0	1.25	31.8	0.75	19.1	0.03	0.76	0.35	8.9	7/16	4500(310)	
10M	UH-WXA-10M-191	1.0	1.23	31.2	0.75	19.1	0.03	0.76	0.43	10.9	5/8	3500(240)	
12M	UH-WXA-12M-191	1.0	1.34	34.0	0.75	19.1	0.04	1.0	0.52	13.2	5/8	2900(200)	

Auto Butt Weld Long Reducing Tee

WRTA

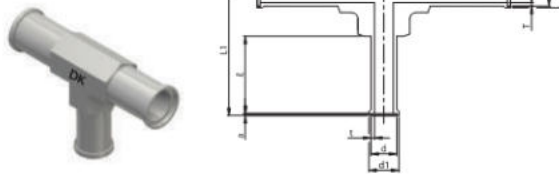

Size (D)	Size (d)	Part No.	Thickness(Wall) T		Thickness(Wall) t		L		L1		ℓ		D1		d1		A		a		H Body Cube	Working Pressure	
			in.	mm	in.	mm	in.	mm	in.	mm	in.	mm	in.	mm	in.	mm	in.	mm	in.	mm			
3/8	1/4	UH-WRTA-6X4-191	0.035	0.8	0.035	0.8	1.23	31.2	1.25	31.8	0.75	19.1	0.41	10.4	0.29	7.4	0.03	0.76	0.02	0.51	7/16	3300(227)	
1/2	1/4	UH-WRTA-8X4-191	0.049	1.2	0.035	0.8	1.38	35.1	1.38	35.1	0.75	19.1	0.55	14.0	0.29	7.4	0.04	1.0	0.02	0.51	11/16	3700(254)	
1/2	3/8	UH-WRTA-8X6-191	0.049	1.2	0.035	0.8	1.38	35.1	1.37	34.8	0.75	19.1	0.55	14.0	0.41	10.4	0.04	1.0	0.03	0.76	11/16	3300(227)	
3/4	3/8	UH-WRTA-12X6-191	0.049	1.2	0.035	0.8	1.50	38.1	1.50	38.1	0.75	19.1	0.80	20.3	0.41	10.4	0.04	1.0	0.03	0.76	15/16	2400(165)	
3/4	1/2	UH-WRTA-12X8-191	0.049	1.2	0.049	1.2	1.50	38.1	1.50	38.1	0.75	19.1	0.80	20.3	0.55	14.0	0.04	1.0	0.04	1.0	15/16	2400(165)	
Metric	Part No.	mm		mm		in.	mm	in.	mm	in.	mm	in.	mm	in.	mm	in.	mm	in.	mm	in.	mm	in.	psig(bar)
12M	6M	UH-WRTA-12MX6M-191	1.0	1.0	1.38	35.1	1.36	34.5	0.75	19.1	0.52	13.2	0.27	6.8	0.02	0.51	0.02	0.51	11/16	2900(200)			

Auto Butt Weld Union

WUA

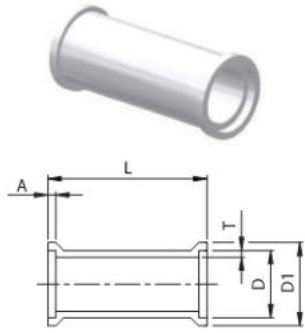

Tube Size (D)	Part No.	Thickness (Tube Wall)		L		A		D1		Working Pressure psig(bar)
		in.	mm	in.	mm	in.	mm	in.	mm	
1/4	UH-WUA-4	0.035	0.8	1.0	25.4	0.02	0.51	0.29	7.4	5100(351)
3/8	UH-WUA-6	0.035	0.8	1.0	25.4	0.03	0.76	0.41	10.4	3300(227)
1/2	UH-WUA-8	0.049	1.2	1.0	25.4	0.04	1.0	0.55	14.0	3700(254)
3/4	UH-WUA-12	0.049	1.2	1.0	25.4	0.04	1.0	0.80	20.3	2400(165)
1	UH-WUA-16	0.065	1.6	1.25	31.8	0.04	1.0	1.06	26.9	2400(165)
Metric	Part No.	mm		in.	mm	in.	mm	in.	mm	psig(bar)
6M	UH-WUA-6M	1.0	1.25	31.8	0.02	0.51	0.27	6.8	6100(420)	
8M	UH-WUA-8M	1.0	1.25	31.8	0.03	0.76	0.35	8.9	4500(310)	
10M	UH-WUA-10M	1.0	1.25	31.8	0.03	0.76	0.43	10.9	3500(240)	
12M	UH-WUA-12M	1.0	1.25	31.8	0.04	1.0	0.52	13.2	2900(200)	
18M	UH-WUA-18M	1.5	1.25	31.8	0.04	1.0	0.76	19.3	2900(200)	

Auto Butt Weld Reducing Union

WRUA

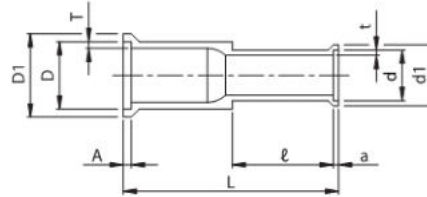

Size (D)	Size (d)	Part No.	Thickness(Wall) T		Thickness(Wall) t		L		l		D1		d1		A		a		Working Pressure psig(bar)
			in.	mm	in.	mm	in.	mm	in.	mm	in.	mm	in.	mm	in.	mm	in.	mm	
3/8	1/4	UH-WRUA-6x4-191	0.035	0.8	0.035	0.8	1.58	40.1	0.75	19.1	0.41	10.4	0.29	7.4	0.03	0.76	0.02	0.51	3300(227)
1/2	1/4	UH-WRUA-8x4-191	0.049	1.2	0.035	0.8	1.58	40.1	0.75	19.1	0.55	14.0	0.29	7.4	0.04	1.0	0.02	0.51	3700(254)
1/2	3/8	UH-WRUA-8x6-191	0.049	1.2	0.035	0.8	1.58	40.1	0.75	19.1	0.55	14.0	0.41	10.4	0.04	1.0	0.03	0.76	3300(227)
3/4	1/2	UH-WRUA-12x8-191	0.049	1.2	0.049	1.2	1.62	41.1	0.75	19.1	0.80	20.3	0.55	14.0	0.04	1.0	0.04	1.0	2400(165)
Metric		Part No.	mm		mm		in.	mm	in.	mm	in.	mm	in.	mm	in.	mm	in.	mm	psig(bar)
8M	6M	UH-WRUA-8Mx6M-191	1.0	1.0	1.57	39.9	0.75	19.1	0.35	8.9	0.27	6.9	0.03	0.76	0.02	0.51	4500(310)		
12M	6M	UH-WRUA-12Mx6M-191	1.0	1.0	1.58	40.1	0.75	19.1	0.52	13.2	0.27	6.9	0.04	1.0	0.02	0.51	2900(200)		
12M	8M	UH-WRUA-12Mx8M-191	1.0	1.0	1.59	40.4	0.75	19.1	0.52	13.2	0.35	8.9	0.04	1.0	0.03	0.76	2900(200)		

Pressure Rating

All pressure rating follow the calculation as to ASME B31.3 Process Piping code and ASME B31.1 Power Piping code.

The working pressure rating at the room temperature is determined by the material of gasket and the allowable temperature range per the materials is listed in Table 2.

Table 2. Temperature range

Part	Material	Temperature °F (°C)
Fitting	316L Stainless Steel	1000 (537)
	316L Stainless Steel VAR	
Gasket	316L Stainless Steel	1000 (537)
	Nickel	600 (315)

Material

Material	Designation	Specification	
		Bar stock	Forging
316L Stainless Steel	SL	ASME SA479	ASME SA182
316L Stainless Steel VAR	DL	ASTM A479/A276	ASTM A182
Gasket	316L Stainless Steel	ASTM A167	
	Nickel	ASTM B162	

Feature

- Leak-tight service provided from vacuum to positive pressure application
- Minimized space is needed for installation and or removal

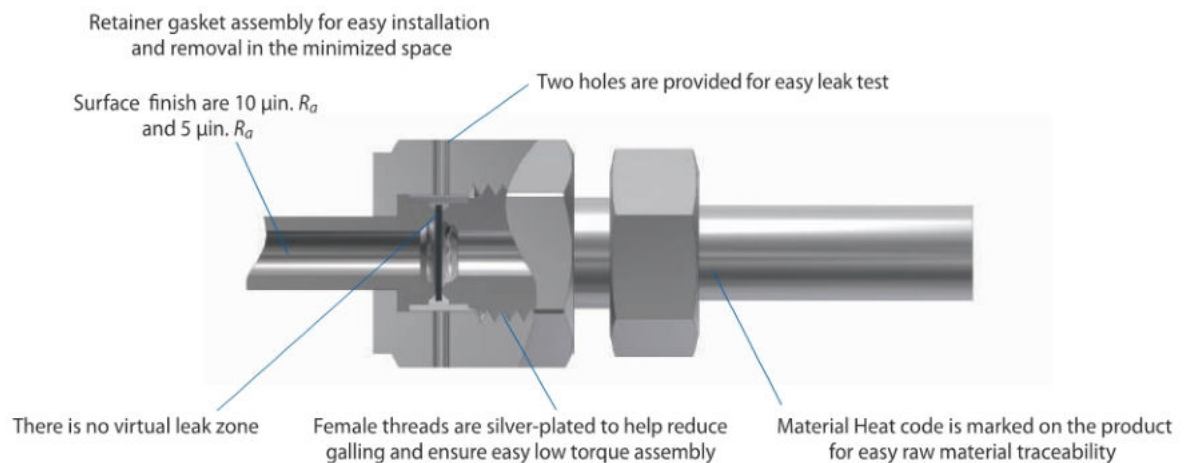

Cleaning & Packing

Passivation is done in accordance with ASTM A380, Ultra-sonic cleaning is performed in a class 100 environment with resistivity over 18MΩ D.I water after finishing the passivation for precision cleaning. After cleaning, all product is double packed in the clean room using anti-static polyethylene bags where high purity nitrogen inclusion.

Surface Roughness

Grade	Designation	Surface Level	
BA	B	$R_a : 10\mu\text{in}$	$R_y : 3.0\mu\text{m}$
EP	P	$R_a : 5\mu\text{in}$	$R_y : 0.7\mu\text{m}$

Plating

The internal surface of the female-threaded nut are silver plated to help reduce galling and reduces the pull-up torque.

Note : In the event of the damage or removal of the silver plating, thread galling may occur damaging the fitting components and preventing against proper sealing performance.

Testing

DCR Fittings are rated to a helium leak rate of less than 1×10^{-9} mbar.l/sec and tested in accordance with SEMI F1-96 and SEMA-90120391B-STD.

Metal Gasket Face-Seal Fittings

Short Gland

SG

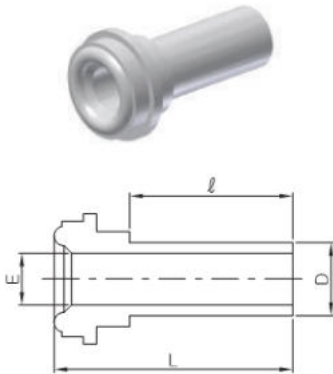

Part No.	Head Size (in.)	Tube Size (D)		L		ℓ		E		Working Pressure (psig)(bar)
		in.	mm	in.	mm	in.	mm	in.	mm	
UH-SG-2-191	1/8	1/8	3.17	1.08	27.40	0.75	19.1	0.06	1.5	8500(585)
UH-SG-4-64	1/4	1/4	6.35	0.6	15.20	0.25	6.4	0.18	4.6	5100(350)
UH-SG-4-96	1/4	1/4	6.35	0.72	18.30	0.38	9.6	0.18	4.6	5100(350)
UH-SG-4-191	1/4	1/4	6.35	1.1	27.95	0.75	19.1	0.18	4.6	5100(350)
UH-SG-6-64	1/2	3/8	9.53	0.62	15.80	0.25	6.4	0.31	7.9	3300(227)
UH-SG-6-191	1/2	3/8	9.53	1.12	28.50	0.75	19.1	0.31	7.9	3300(227)
UH-SG-8-64	1/2	1/2	12.7	0.62	15.80	0.25	6.4	0.40	10.2	3500(241)
UH-SG-8-96	1/2	1/2	12.7	0.74	18.80	0.38	9.6	0.40	10.2	3500(241)
UH-SG-8-191	1/2	1/2	12.7	1.12	28.50	0.75	19.1	0.40	10.2	3500(241)
UH-SG-8X4-191	1/2	1/4	6.35	1.12	28.50	0.75	19.1	0.18	4.6	4300(296)
Metric	in.	mm	in.	mm	in.	mm	mm	mm	psig(bar)	
UH-SG-4X6M-191	1/4	6.0	1.16	29.5	0.75	19.1	4.0	6800(468)		
UH-SG-4X8M-191	1/4	8.0	1.16	29.5	0.75	19.1	6.0	4900(337)		
UH-SG-8X10M-191	1/2	10.0	1.16	29.5	0.75	19.1	8.0	3500(241)		
UH-SG-8X12M-191	1/2	12.0	1.16	29.5	0.75	19.1	10.0	3100(213)		
UH-SG-12X18M-191	3/4	18.0	1.22	31.0	0.75	19.1	15.0	3000(206)		

Long Gland

LG

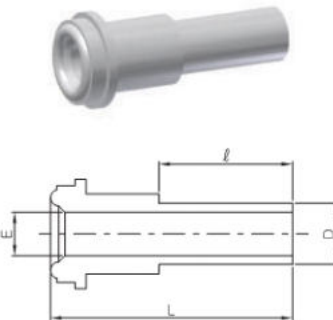

Part No.	Head Size (in.)	Tube Size (D)		L		ℓ		E		Working Pressure (psig)(bar)
		in.	mm	in.	mm	in.	mm	in.	mm	
UH-LG-2-191	1/8	1/8	3.17	1.42	36.1	0.75	19.1	0.06	1.5	8500(585)
UH-LG-4-64	1/4	1/4	6.35	1.20	30.5	0.25	6.4	0.18	4.6	5100(350)
UH-LG-4-91	1/4	1/4	6.35	1.31	33.3	0.36	9.1	0.18	4.6	5100(349)
UH-LG-4-96	1/4	1/4	6.35	1.32	33.5	0.38	9.6	0.18	4.6	5100(350)
UH-LG-4-191	1/4	1/4	6.35	1.70	43.2	0.75	19.1	0.18	4.6	5100(350)
UH-LG-6-64	1/2	3/8	9.53	1.29	32.8	0.25	6.4	0.31	7.9	3300(227)
UH-LG-6-191	1/2	3/8	9.53	1.79	45.5	0.75	19.1	0.31	7.9	3300(227)
UH-LG-8-64	1/2	1/2	12.7	1.29	32.8	0.25	6.4	0.40	10.2	3500(241)
UH-LG-8-96	1/2	1/2	12.7	1.41	35.8	0.38	9.6	0.40	10.2	3500(241)
UH-LG-8-191	1/2	1/2	12.7	1.79	45.5	0.75	19.1	0.40	10.2	3500(241)
UH-LG-8X4-191	1/2	1/4	6.35	1.80	45.7	0.75	19.1	0.18	4.6	4300(296)
UH-LG-12-191	3/4	3/4	19.05	2.03	51.6	0.75	19.1	0.65	16.5	2400(165)
UH-LG-16-191	1	1	25.4	2.32	58.9	0.75	19.1	0.87	22.1	2400(165)
Metric	in.	mm	in.	mm	in.	mm	mm	mm	psig(bar)	
UH-LG-4X6M-191	1/4	6.0	1.70	43.2	0.75	19.1	4.0	6800(468)		
UH-LG-4X8M-191	1/4	8.0	1.70	43.2	0.75	19.1	6.0	4900(337)		
UH-LG-8X10M-191	1/2	10.0	1.79	45.5	0.75	19.1	8.0	3500(241)		
UH-LG-8X12M-191	1/2	12.0	1.79	45.5	0.75	19.1	10.0	3100(213)		
UH-LG-12X18M-191	3/4	18.0	2.03	51.6	0.75	19.1	15.0	3000(206)		

Auto Butt Weld Short Gland

SGA

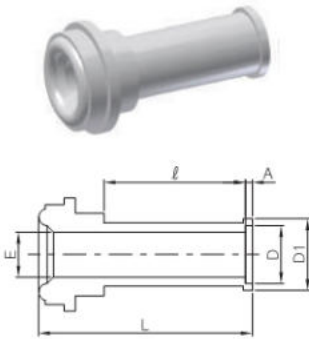

Part No.	Tube Size (D)		Head Size (in.)	D1		E		A		L		ℓ		Working Pressure psig(bar)
	in.	mm		in.	mm	in.	mm	in.	mm	in.	mm	in.	mm	
UH-SGA-4-64	1/4	6.35	1/4	0.29	7.4	0.18	4.6	0.02	0.5	0.62	15.7	0.25	6.4	5100(351)
UH-SGA-4-191	1/4	6.35	1/4	0.29	7.4	0.18	4.6	0.02	0.5	1.12	28.4	0.75	19.1	5100(351)
UH-SGA-6-64	3/8	9.53	1/2	0.41	10.4	0.31	7.9	0.03	0.8	0.65	16.6	0.25	6.4	3300(227)
UH-SGA-6-191	3/8	9.53	1/2	0.41	10.4	0.31	7.9	0.03	0.8	1.15	29.2	0.75	19.1	3300(227)
UH-SGA-8-64	1/2	12.7	1/2	0.55	14.0	0.40	10.2	0.04	1.0	0.66	16.8	0.25	6.4	3500(241)
UH-SGA-8-191	1/2	12.7	1/2	0.55	14.0	0.40	10.2	0.04	1.0	1.16	29.5	0.75	19.1	3500(241)
Metric	mm	in.	in.	mm	mm	in.	mm	in.	mm	in.	mm	in.	mm	psig(bar)
UH-SGA-6M-191	6.0	1/4	0.27	6.8	4.0	0.02	0.5	1.18	30.0	0.75	19.1	6800(468)		
UH-SGA-8M-191	8.0	1/4	0.35	8.9	6.0	0.03	0.8	1.19	30.2	0.75	19.1	4900(337)		
UH-SGA-10M-191	10.0	1/2	0.43	10.9	8.0	0.03	0.8	1.22	31.0	0.75	19.1	3500(241)		
UH-SGA-12M-191	12.0	1/2	0.52	13.2	10.0	0.04	1.0	1.20	30.5	0.75	19.1	3100(213)		

Auto Butt Weld Long Gland

LGA

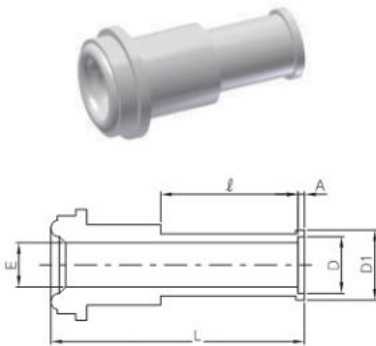

Part No.	Head Size (in.)	Tube Size (D)		D1		E		A		L		ℓ		Working Pressure psig(bar)
		in.	mm	in.	mm	in.	mm	in.	mm	in.	mm	in.	mm	
UH-LGA-4-191	1/4	1/4	6.35	0.29	7.4	0.18	4.6	0.02	0.5	1.72	43.7	0.75	19.1	5100(351)
UH-LGA-8X4-191	1/2	1/4	6.35	0.29	7.4	0.18	4.6	0.02	0.5	1.82	46.2	0.75	19.1	3500(241)
UH-LGA-6-191	1/2	3/8	9.53	0.41	10.4	0.31	7.9	0.03	0.8	1.82	46.2	0.75	19.1	3300(227)
UH-LGA-8-191	1/2	1/2	12.7	0.55	14.0	0.40	10.2	0.04	1.0	1.83	46.5	0.75	19.1	3500(241)
UH-LGA-12-191	3/4	3/4	19.05	0.8	20.3	0.65	16.5	0.04	1.0	2.07	52.6	0.75	19.1	2400(165)
UH-LGA-16-244	1	1	25.4	1.06	26.9	0.87	22.1	0.04	1.0	2.57	65.3	0.96	24.4	2400(165)
Metric	in.	mm	in.	mm	mm	in.	mm	in.	mm	in.	mm	in.	mm	psig(bar)
UH-LGA-6M-191	1/4	6.0	0.27	6.8	4.0	0.02	0.5	1.72	43.7	0.75	19.1	6800(468)		
UH-LGA-8M-191	1/4	8.0	0.35	8.9	6.0	0.03	0.8	1.73	43.9	0.75	19.1	4900(337)		
UH-LGA-10M-191	1/2	10.0	0.43	10.9	8.0	0.03	0.8	1.83	46.5	0.75	19.1	3500(241)		
UH-LGA-12M-191	1/2	12.0	0.52	13.2	10.0	0.04	1.0	1.83	46.5	0.75	19.1	3100(213)		
UH-LGA-18M-191	3/4	18.0	0.76	19.3	15.0	0.04	1.0	2.07	52.6	0.75	19.1	3000(206)		

Male Gland

GM

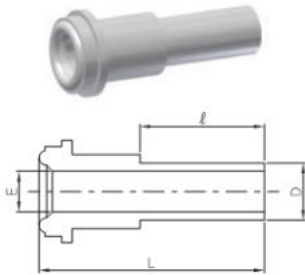

Part No.	Head Size (in.)	Tube Size (D)		E		L		ℓ		Working Pressure psig(bar)
		in.	mm	in.	mm	in.	mm	in.	mm	
UH-GM-2	1/8	1/8	3.17	0.06	1.5	0.70	17.8	0.28	7.1	11200(771)
UH-GM-4X2	1/4	1/8	3.17	0.06	1.5	1.31	33.3	0.28	7.1	10000(689)
UH-GM-4	1/4	1/4	6.35	0.12	3.0	1.31	33.3	0.41	10.4	10000(689)
UH-GM-6	1/2	3/8	9.53	0.28	7.1	1.50	38.1	0.41	10.4	4300(296)
UH-GM-8	1/2	1/2	12.7	0.4	10.2	1.50	38.1	0.50	12.7	3500(241)
UH-GM-8X4	1/2	1/4	6.35	0.12	3.0	1.50	38.1	0.41	10.4	4300(296)
UH-GM-12	3/4	3/4	19.05	0.53	13.5	2.00	50.8	0.62	15.7	3700(254)
UH-GM-16	1	1	25.4	0.75	19.1	2.22	56.4	0.81	20.6	3000(206)

Socket Weld Long Gland

GSL

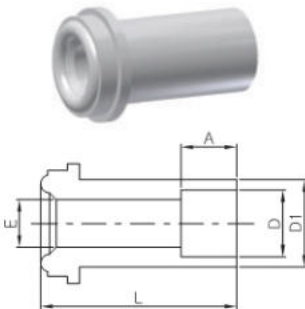

Part No.	Tube Size (D)		Head Size (in.)	D1		E		L		A		Working Pressure psig(bar)
	in.	mm		in.	mm	in.	mm	in.	mm	in.	mm	
UH-GSL-2	1/8	3.17	1/8	0.20	5.1	0.09	2.3	0.70	17.8	0.10	2.5	7100(489)
UH-GSL-4	1/4	6.35	1/4	0.35	8.9	0.18	4.6	1.31	33.3	0.28	7.1	5500(378)
UH-GSL-6	3/8	9.53	1/2	0.60	15.2	0.28	7.1	1.50	38.1	0.31	7.9	4300(291)
UH-GSL-8	1/2	12.7	1/2	0.60	15.2	0.40	10.2	1.50	38.1	0.38	9.6	3000(206)
UH-GSL-12	3/4	19.05	3/4	0.88	22.4	0.62	15.7	2.00	50.8	0.44	11.2	2800(192)
UH-GSL-16	1	25.4	1	1.19	30.2	0.87	22.1	2.22	56.4	0.62	15.7	3000(206)

Socket Weld Reducing Long Gland

GSR

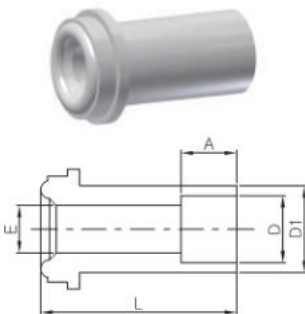

Part No.	Head Size (in.)	Tube Size (D)		D1		E		L		A		Working Pressure psig(bar)
		in.	mm	in.	mm	in.	mm	in.	mm	in.	mm	
UH-GSR-4X2	1/4	1/8	3.17	0.35	8.9	0.09	2.3	1.31	33.3	0.10	2.5	8000(551)
UH-GSR-8X4	1/2	1/4	6.35	0.60	15.2	0.18	4.6	1.50	38.1	0.28	7.1	3500(241)

Socket Weld Short Gland

GSS

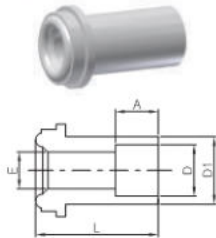

Part No.	Tube Size (D)		Head Size (in.)	D1		E		L		A		Working Pressure psig(bar)
	in.	mm		in.	mm	in.	mm	in.	mm	in.	mm	
UH-GSS-4	1/4	6.35	1/4	0.35	8.9	0.18	4.6	0.50	12.7	0.28	7.1	5500(378)
UH-GSS-4-19								0.75	19.1			

Tube Adapter Gland

GT

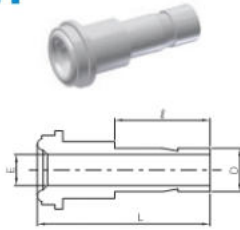

Part No.	Tube Size (D)		Head Size (in.)	E		L		ℓ		Working Pressure psig(bar)
	in.	mm		in.	mm	in.	mm	in.	mm	
UH-GT-4	1/4	6.35	1/4	0.17	4.3	1.62	41.0	0.64	16.2	10000
UH-GT-6	3/8	9.53	1/2	0.27	6.8	1.81	46.0	0.70	17.8	4300
UH-GT-8	1/2	12.7		0.37	9.4	1.94	49.3	0.96	24.4	4300

Blind Gland

BG

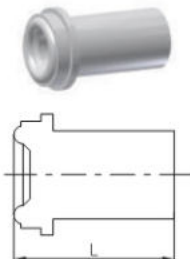

Part No.	Tube Size (D)		Head Size (in.)	L	
	in.	mm		in.	mm
UH-BG-2	1/8	3.17	1/8	0.70	17.8
UH-BG-4	1/4	6.35	1/4	1.31	33.3
UH-BG-8	1/2	12.7	1/2	1.50	38.1
UH-BG-12	3/4	19.05	3/4	2.00	50.8
UH-BG-16	1	25.4	1	2.22	56.4

Female Nut

FN

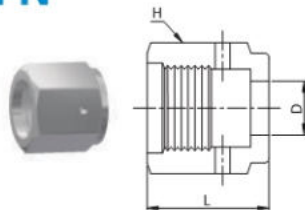

Part No.	Size (in.)	L		D		H Hex (in.)
		in.	mm	in.	mm	
U-FN-2	1/8	0.53	13.5	0.21	5.3	7/6
U-FN-4	1/4	0.81	20.6	0.36	9.1	3/4
U-FN-8	1/2	0.88	22.4	0.61	15.5	1 1/16
U-FN-12	3/4	1.12	28.4	0.89	22.6	1 1/2
U-FN-16	1	1.34	34.0	1.20	30.5	1 3/4

Male Nut

MN

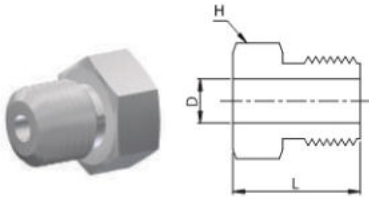

Part No.	Size (in.)	L		D		H Hex (in.)
		in.	mm	in.	mm	
U-MN-2	1/8	0.50	12.7	0.21	5.3	3/8
U-MN-4	1/4	0.71	18.0	0.36	9.1	5/8
U-MN-8	1/2	0.81	20.6	0.61	15.5	15/16
U-MN-12	3/4	1.00	25.4	0.89	22.6	1 5/16
U-MN-16	1	1.19	30.2	1.20	30.5	1 5/8

Cap

CP

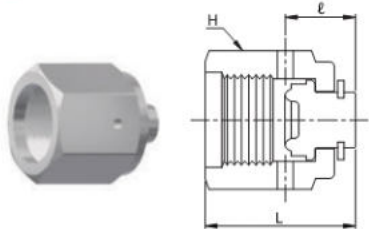

Part No.	Size (in.)	L		ℓ		H Hex (in.)
		in.	mm	in.	mm	
U-CP-2	1/8	0.63	16.0	0.30	7.6	7/16
U-CP-4	1/4	0.94	23.9	0.44	11.2	3/4
U-CP-8	1/2	1.01	25.6	0.45	11.4	1 1/16
U-CP-12	3/4	1.29	32.8	0.54	13.7	1 1/2
U-CP-16	1	1.54	39.1	0.63	16.0	1 3/4

Plug

PG

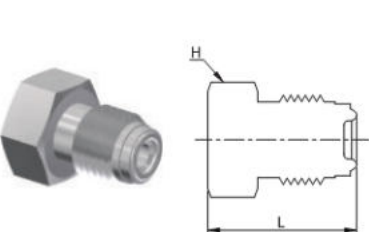

Part No.	Size (in.)	L		H Hex (in.)
		in.	mm	
U-PG-2	1/8	0.68	17.3	3/8
U-PG-4	1/4	0.92	23.4	5/8
U-PG-8	1/2	1.08	27.4	15/16
U-PG-12	3/4	1.43	36.3	1 5/16
U-PG-16	1	1.52	38.6	1 5/8

Gasket

GK

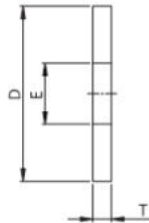

Part No.	Size (in.)	T		D		E	
		in.	mm	in.	mm	in.	mm
U-GK-2	1/8	0.028	0.7	0.26	6.6	0.09	2.3
U-GK-4	1/4	0.028	0.7	0.50	12.7	0.22	5.6
U-GK-8	1/2	0.028	0.7	0.78	19.8	0.44	11.2
U-GK-12	3/4	0.028	0.7	1.14	29.0	0.66	16.7
U-GK-16	1	0.028	0.7	1.40	35.8	1.89	22.6

Gasket Retainer

GKT



Part No.	Size (in.)	T		D		E	
		in.	mm	in.	mm	in.	mm
U-GKT-4	1/4	0.028	0.7	0.47	11.85	0.22	5.6
U-GKT-8	1/2	0.028	0.7	0.76	19.27	0.44	11.2
U-GKT-12	3/4	0.028	0.7	1.10	27.90	0.66	16.7
U-GKT-16	1	0.028	0.7	1.34	34.20	0.89	22.6

Gasket Blind

GKB

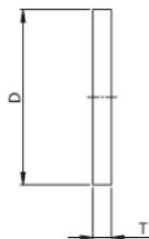

Part No.	Size (in.)	T		D	
		in.	mm	in.	mm
U-GKB-2	1/8	0.028	0.7	0.26	6.6
U-GKB-4	1/4	0.028	0.7	0.50	12.7
U-GKB-8	1/2	0.028	0.7	0.78	19.8
U-GKB-12	3/4	0.028	0.7	1.14	29.0
U-GKB-16	1	0.028	0.7	1.40	35.8

Double Male Union

MU

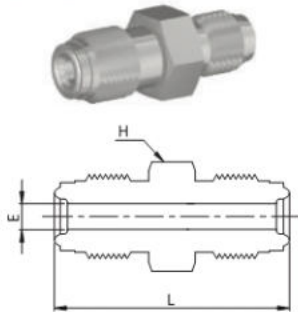

Part No.	Head Size (in.)	L		E		H Hex (in.)
		in.	mm	in.	mm	
UH-MU-2	1/8	1.13	28.7	0.09	2.3	3/8
UH-MU-4	1/4	1.55	39.4	0.18	4.6	5/8
UH-MU-8	1/2	1.84	46.7	0.40	10.2	15/16
UH-MU-12	3/4	2.44	62	0.62	15.7	1 5/16
UH-MU-16	1	2.59	65.8	0.87	22.1	1 5/8

Double Male Reducing Union

MRU

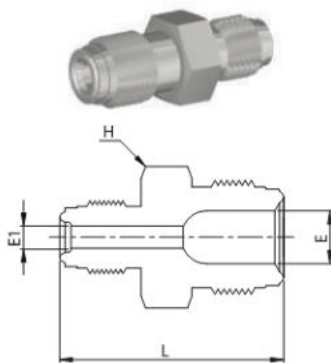

Part No.	Head Size (in.)	Head Size (in.)	L		E		E1		H Hex (in.)
			in.	mm	in.	mm	in.	mm	
UH-MRU-8X4	1/2	1/4	1.71	43.4	0.4	10.2	0.18	4.6	15/16

Bulkhead Union

BHU

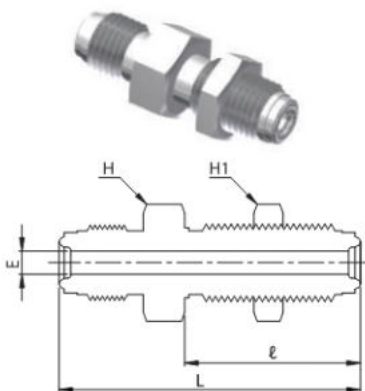

Part No.	Head Size (in.)	L		ℓ		E		H Hex (in.)	H1 Hex (in.)
		in.	mm	in.	mm	in.	mm		
UH-BHU-4	1/4	2.23	56.6	1.30	33.0	0.18	4.6	3/4	3/4
UH-BHU-4-462	1/4	1.82	46.2	0.99	25.1	0.18	4.6	3/4	3/4
UH-BHU-8	1/2	2.57	65.3	1.48	37.6	0.40	10.2	1 1/16	1 1/16
UH-BHU-8-544	1/2	2.14	54.4	1.11	28.2	0.40	10.2	1 1/16	1 1/16

Metal Gasket Face-Seal Fittings

Tube Fitting Connector

DC

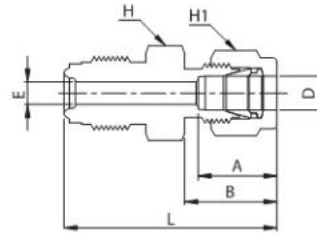

Part No.	Head Size (in.)	Tube Size (D)	L		B		A		E		H Hex (in.)	H1 Hex (in.)
			in.	mm	in.	mm	in.	mm	in.	mm		
UH-DC-4X2	1/4	1/8	1.53	38.9	0.60	15.2	0.5	12.7	0.09	2.3	5/8	7/16
UH-DC-4	1/4	1/4	1.62	41.1	0.70	17.8	0.6	15.2	0.18	4.6	5/8	9/16
UH-DC-8X6	1/2	3/8	1.84	46.7	0.76	19.3	0.66	16.8	0.28	7.1	15/16	11/16
UH-DC-8	1/2	1/2	1.95	49.5	0.86	21.8	0.9	22.9	0.4	10.2	15/16	7/8

Tube Fitting Bulkhead Connector

DBHC

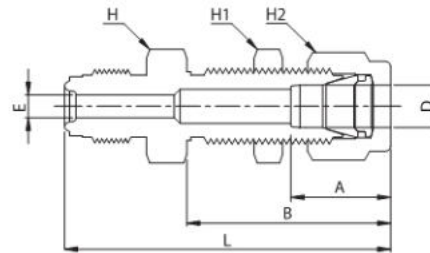

Part No.	Head Size (in.)	Tube Size (D)	L		B		A		E		H Hex (in.)	H1 Hex (in.)	H2 Hex (in.)
			in.	mm	in.	mm	in.	mm	in.	mm			
UH-DBHC-4	1/4	1/4	2.25	57.2	1.32	33.5	0.6	15.2	0.18	4.6	5/8	5/8	9/16
UH-DBHC-4-478	1/4	1/4	1.88	47.8	1.05	26.7	0.6	15.2	0.18	4.6	5/8	5/8	9/16
UH-DBHC-8X6	1/2	3/8	2.54	64.5	1.45	36.8	0.66	16.8	0.28	7.1	15/16	3/4	11/16
UH-DBHC-8	1/2	1/2	2.74	69.6	1.65	41.9	0.9	22.9	0.4	10.2	15/16	15/16	7/8

Male NPT Connector

MC-N

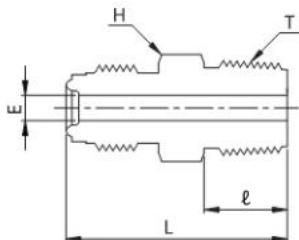

Part No.	Head Size (in.)	Size NPT T	L		ℓ		E		H Hex (in.)
			in.	mm	in.	mm	in.	mm	
UH-MC4-2N	1/4	1/8	1.31	33.3	0.38	9.6	0.18	4.6	5/8
UH-MC4-4N	1/4	1/4	1.49	37.8	0.56	14.2	0.18	4.6	5/8
UH-MC8-4N	1/2	1/4	1.65	41.9	0.56	14.2	0.28	7.1	15/16
UH-MC8-6N	1/2	3/8	1.65	41.9	0.56	14.2	0.38	9.6	15/16
UH-MC8-8N	1/2	1/2	1.84	46.7	0.75	19.1	0.40	10.2	15/16
UH-MC12-12N	3/4	3/4	2.19	55.6	0.75	19.1	0.62	15.7	1 5/16
UH-MC16-16N	1	1	2.47	62.7	0.94	23.9	0.87	22.1	1 5/8

Female NPT Connector

FC-N

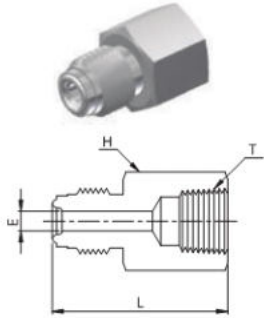

Part No.	Head Size (in.)	Size NPT T	L		E		H Hex (in.)
			in.	mm	in.	mm	
UH-FC4-2N	1/4	1/8	1.41	35.8	0.18	4.6	5/8
UH-FC4-4N	1/4	1/4	1.54	39.1	0.18	4.6	3/4
UH-FC8-6N	1/2	3/8	1.76	44.7	0.40	10.2	15/16
UH-FC8-8N	1/2	1/2	1.99	50.5	0.40	10.2	1 1/16
UH-FC12-12N	3/4	3/4	2.36	59.9	0.62	15.7	1 5/16
UH-FC16-16N	1	1	2.51	63.8	0.87	22.1	1 5/8

Bulkhead Male NPT Connector

BHMC-N

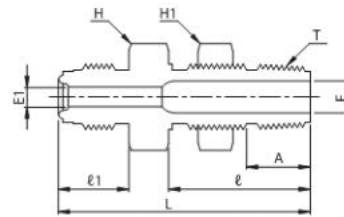

Part No.	Head Size (in.)	Size NPT T	L		ℓ1		A		E		E1		ℓ		H Hex (mm)	H1 Hex (mm)
			in.	mm	in.	mm	in.	mm	in.	mm	in.	mm	in.	mm		
UH-BHMC4-4N	1/4	1/4	2.21	56.1	0.62	15.7	0.56	14.2	0.28	7.1	0.18	4.6	1.24	31.5	20.63	20.63
UH-BHMC8-4N	1/2	1/4	2.34	59.4	0.75	19.1	0.56	14.2	0.28	7.1	0.4	10.2	1.24	31.5	23.81	20.63

Tube Butt Weld Bulkhead Connector

BHTW

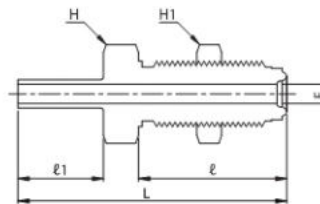

Part No.	Head Size (in.)	L		ℓ		ℓ1		E		H Hex (in.)	H1 Hex (in.)
		in.	mm	in.	mm	in.	mm	in.	mm		
UH-BHTW-4	1/4	2.36	59.9	1.3	33	0.75	19.1	0.18	4.6	3/4	3/4
UH-BHTW-4-495	1/4	1.95	49.5	0.99	25.1	0.75	19.1	0.18	4.6	3/4	3/4

Metal Gasket Face-Seal Fittings

Straight Thread O-Ring Seal Male Connector

MC-UO

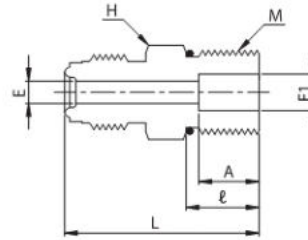

Part No.	Head Size (in.)	L		ℓ		A		E		E1		H Hex (in.)	M
		in.	mm	in.	mm	in.	mm	in.	mm	in.	mm		
UH-MC4-6U	1/4	1.33	33.8	0.39	9.9	0.25	6.4	0.18	4.6	0.28	7.1	3/4	9/16-18 UNF
UH-MC8-6U	1/2	1.48	37.6	0.39	9.9	-	-	0.28	7.1	0.28	7.1	15/16	9/16-18 UNF
UH-MC8-10U	1/2	1.66	42.2	0.5	12.7	0.4	10.2	0.28	7.1	0.59	15	1	7/8-14 UNF

Union Elbow

L

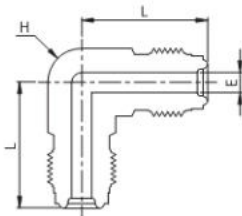

Part No.	Head Size (in.)	L		E		H Hex (in.)
		in.	mm	in.	mm	
UH-L-4	1/4	1.07	27.2	0.18	4.6	1/2
UH-L-8	1/2	1.45	36.8	0.40	10.2	13/16
UH-L-12	3/4	1.92	48.8	0.62	15.7	1 1/4
UH-L-16	1	2.00	50.8	0.87	22.1	1 11/16

Union Tee

T

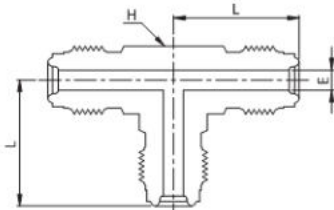

Part No.	Head Size (in.)	L		E		H Hex (in.)
		in.	mm	in.	mm	
UH-T-4	1/4	1.07	27.2	0.18	4.6	1/2
UH-T-8	1/2	1.45	36.8	0.40	10.2	13/16
UH-T-12	3/4	1.92	48.8	0.62	15.7	1 1/4
UH-T-16	1	2.00	50.8	0.87	22.1	1 11/16

Union Cross Tee

X

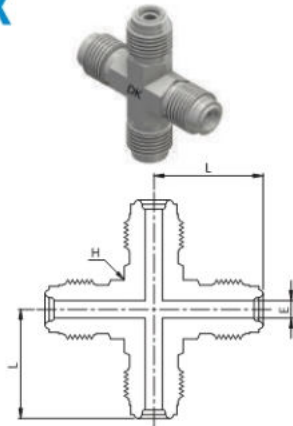

Part No.	Head Size (in.)	L		E		H Hex (in.)
		in.	mm	in.	mm	
UH-X-4	1/4	1.07	27.2	0.18	4.6	1/2
UH-X-8	1/2	1.45	36.8	0.40	10.2	13/16
UH-X-12	3/4	1.92	48.8	0.62	15.7	1 1/4
UH-X-16	1	2.00	50.8	0.87	22.1	1 11/16

Male NPT Elbow

ML-N

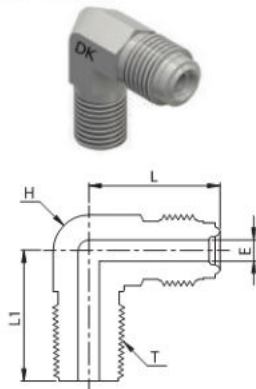

Part No.	Head Size (in.)	Size NPT T	L		L1		E		H Hex (in.)
			in.	mm	in.	mm	in.	mm	
UH-ML4-2N	1/4	1/8	1.07	27.2	0.87	22.1	0.18	4.6	1/2
UH-ML4-4N	1/4	1/4	1.07	27.2	1.05	26.7	0.18	4.6	1/2
UH-ML8-6N	1/2	3/8	1.45	36.8	1.26	32.0	0.4	10.2	13/16
UH-ML8-8N	1/2	1/2	1.45	36.8	1.45	36.8	0.4	10.2	13/16

Coupling

C

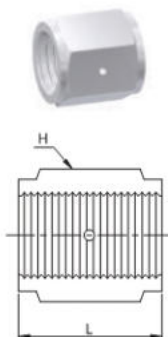

Part No.	Size (in.)	L		H Hex (in.)
		in.	mm	
U-C-2	1/8	0.66	16.8	7/16
U-C-4	1/4	1.19	30.2	3/4
U-C-8	1/2	1.31	33.3	1 1/16
U-C-12	3/4	1.68	42.7	1 1/2
U-C-16	1	2.04	51.8	1 3/4

High Flow Fittings

High Flow Gland

HG

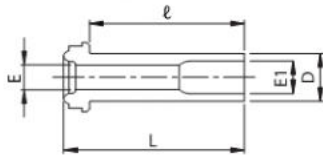

Part No.	Head Size (in.)	D	E1		E		L		l	
			in.	mm	in.	mm	in.	mm	in.	mm
U-HG-4X6	1/4	3/8	0.31	7.9	0.25	6.4	1.31	33.3	1.12	28.4

High Flow Reducer

HR

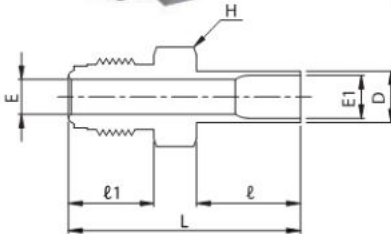

Part No.	Head Size (in.)	D	L		l		l1		E		E1		H Hex (in.)
			in.	mm	in.	mm	in.	mm	in.	mm	in.	mm	
U-HR-4X6	1/4	3/8	1.68	42.7	0.75	19.1	0.62	15.7	0.25	6.4	0.31	7.9	5/8

Auto Butt Weld High Flow Reducer

HRA

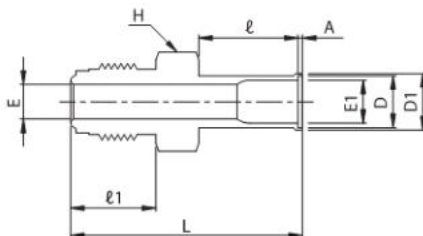

Part No.	Head Size (in.)	D	L		l		l1		A		E		E1		D1		H Hex (in.)
			in.	mm	in.	mm	in.	mm	in.	mm	in.	mm	in.	mm			
U-HRA-4X6	1/4	3/8	1.71	43.4	0.75	19.1	0.62	15.7	0.03	0.8	0.25	6.4	0.31	7.9	0.41	10.4	5/8

High Flow Bulkhead Reducer

HBR

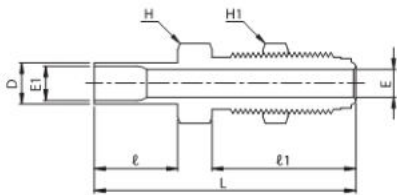

Part No.	Head Size (in.)	D	L		l		l1		E		E1		H Hex (in.)	H1 Hex (in.)
			in.	mm	in.	mm	in.	mm	in.	mm	in.	mm		
U-HBR-4X6	1/4	3/8	2.36	59.9	0.75	19.1	1.3	33	0.25	6.4	0.31	7.9	3/4	3/4

High Flow Union Elbow

HL

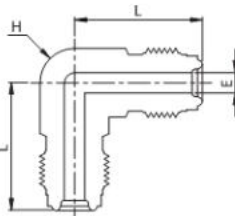

Part No.	Head Size (in.)	L		E		H Hex (in.)
		in.	mm	in.	mm	
U-HL-4	1/4	1.07	27.2	0.25	6.4	1/2

High Flow Union Tee

HT

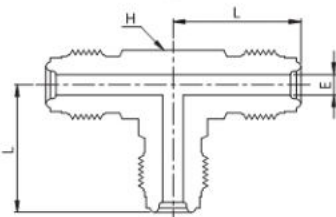

Part No.	Head Size (in.)	L		E		H Hex (mm)
		in.	mm	in.	mm	
U-HT-4	1/4	1.07	27.2	0.25	6.4	12.7

High Flow Female Nut

HFN

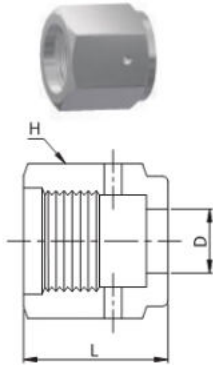

Part No.	Head Size (in.)	L		D		H Hex (in.)
		in.	mm	in.	mm	
U-HFN-4	1/4	0.81	20.6	0.39	9.9	3/4

High Flow Male Nut

HMN

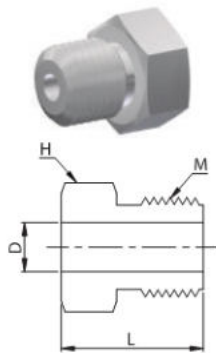

Part No.	Head Size (in.)	L		D		H Hex (in.)	M
		in.	mm	in.	mm		
U-HMN-4	1/4	0.71	18.0	0.39	9.9	5/8	9/16-18 UNF

Tube Fitting to Auto Butt Weld Connector

DATW

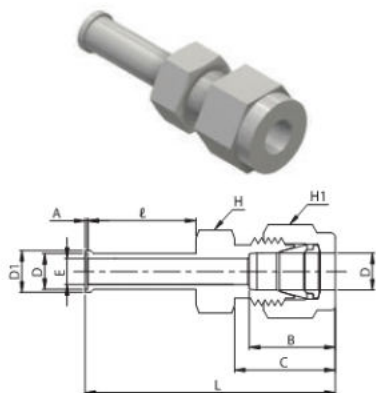

Part No.	Head Size (in.)	D	D1		L		ℓ		A		B		C		E		H Hex (in.)	H1 Hex (in.)
			in.	mm	in.	mm	in.	mm	in.	mm	in.	mm	in.	mm	in.	mm		
U-DATW-4X4	1/4	1/4	0.29	7.4	1.74	44.2	0.75	19.1	0.02	0.5	0.60	15.2	0.70	17.8	0.18	4.6	1/2	9/16
U-DATW-6X6	3/8	3/8	0.41	10.4	1.84	46.7	0.75	19.1	0.02	0.5	0.22	16.8	0.76	19.3	0.31	7.9	5/8	11/16

Welded Assembly Fittings

Swivel Female / Male Union

SFMU

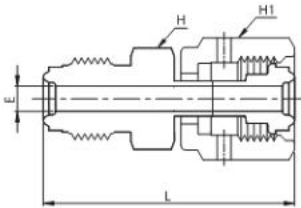

Part No.	Head Size (in.)	L		E		H Hex (in.)	H1 Hex (in.)
		in.	mm	in.	mm		
U-SFMU-4	1/4	1.78	45.3	0.18	4.6	5/8	3/4

Swivel Female Union

SFU

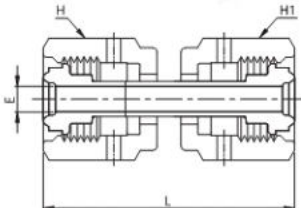

Part No.	Head Size (in.)	L		E		H Hex (in.)	H1 Hex (in.)
		in.	mm	in.	mm		
U-SFU-4	1/4	1.71	43.4	0.18	4.6	3/4	3/4
U-SFU-8	1/2	1.84	46.7	0.40	10.2	1 1/16	1 1/16

Swivel Male NPT Connector

SMC-N

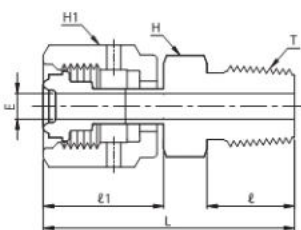

Part No.	Head Size (in.)	Size NPT T	L		l		l1		E		H Hex (in.)	H1 Hex (in.)
			in.	mm	in.	mm	in.	mm	in.	mm		
U-SMC4-2N	1/4	1/8	1.58	40.1	0.38	9.6	0.95	24.1	0.18	4.6	7/16	3/4
U-SMC4-4N	1/4	1/4	1.79	45.5	0.56	14.2	0.92	23.4	0.18	4.6	9/16	3/4
U-SMC8-6N	1/2	3/8	1.89	48.0	0.56	14.2	1.0	25.4	0.40	10.2	11/16	1 1/16
U-SMC8-8N	1/2	1/2	2.09	53.1	0.75	19.1	1.01	25.6	0.40	10.2	7/8	1 1/16

Swivel Female NPT Connector

SFC-N

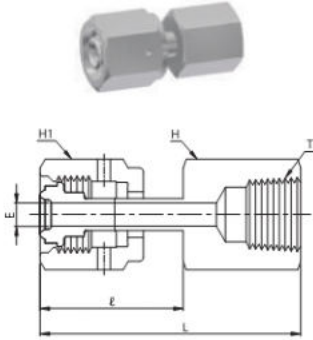

Part No.	Head Size (in.)	Size NPT T	L		ℓ		E		H Hex (in.)	H1 Hex (in.)
			in.	mm	in.	mm	in.	mm		
U-SFC4-4N	1/4	1/4	1.77	45.0	0.92	23.4	0.18	4.6	3/4	3/4
U-SFC8-6N	1/2	3/8	1.95	49.5	1.06	26.9	0.40	10.2	7/8	1 1/16
U-SFC8-8N	1/2	1/2	2.18	55.4	1.04	26.4	0.40	10.2	1 1/16	1 1/16

Swivel Tube Fitting Connector

SDC

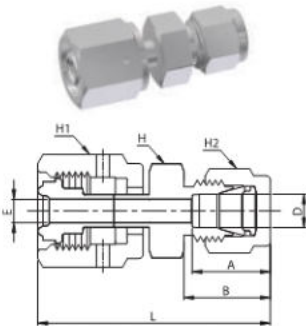

Part No.	Head Size (in.)	Size NPT D	L		A		B		E		H Hex (in.)	H1 Hex (in.)	H2 Hex (in.)
			in.	mm	in.	mm	in.	mm	in.	mm			
U-SDC-4	1/4	1/4	1.94	49.3	0.60	15.2	0.70	17.8	0.18	4.6	1/2	3/4	9/16

Swivel Elbow

SL

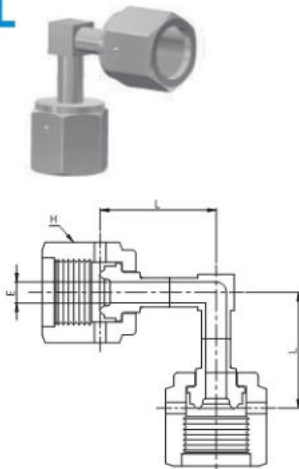

Part No.	Head Size (in.)	L		E		H Hex (in.)
		in.	mm	in.	mm	
U-SL-4	1/4	1.0	25.4	0.18	4.6	3/4

Swivel Tee

ST



Part No.	Head Size (in.)	L		E		H Hex (in.)
		in.	mm	in.	mm	
U-ST-4	1/4	1.0	25.4	0.18	4.6	3/4

