

**Operating Instructions
for
Oval Wheel Flowmeter
High pressure**

**Model:
DON-H...R0/H0/Z1/Z2/Z3**



1. Contents

1. Contents.....	2
2. Note	3
3. Instrument Inspection.....	3
4. Regulation Use.....	4
5. Operating Principle.....	4
6. Mechanical Connection.....	5
6.1 General.....	5
6.2 Orientation	6
7. Electrical Connection	8
7.1 Connecting Cable	8
7.2 Hazardous area wiring.....	8
7.3 Electrical connection for integrated electronics options	8
7.4 Internal wiring with electronic options –Ex/Zx	11
7.5 External wiring with electronic unit ZOK-Zx	13
8. Commissioning.....	15
9. Maintenance	16
9.1 Disassembly of DON-H with Pulse meter	17
9.2 Demounting of the electronics mounted on a DON with Zx and Ex options	19
9.3 Spare Parts.....	19
9.4 Inspection (refer Exploded View).....	19
9.5 Re-assembly of DON-H	19
10. Technical Data	23
11. Pressure drop curves	27
12. Order codes	28
13. Dimensions Electronic Options Ex/Zx	29
14. Troubleshooting	29
15. EU Declaration of Conformance.....	33
16. Manufacturers declaration – Switches for use in Explosive Atmospheres ..	34
17. State of safeness	35

Manufactured and sold by:

KOBOLD Messring GmbH
Nordring 22-24
D-65719 Hofheim
Tel.: +49(0)6192-2990
Fax: +49(0)6192-23398
E-Mail: info.de@kobold.com
Internet: www.kobold.com

2. Note

Please read these operating instructions before unpacking and putting the unit into operation. Follow the instructions precisely as described herein.

The devices are only to be used, maintained, and serviced by persons familiar with these operating instructions and in accordance with local regulations applying to Health & Safety and prevention of accidents.

When used in machines, the measuring unit should be used only when the machines fulfil the EC-machine guidelines.

as per PED 2014/68/EU

In acc. with Article 4 Paragraph (3), "Sound Engineering Practice", of the PED 2014/68/EU no CE mark.

Model DON-*	DN	P _{max} [bar]	Diagram 8 Group 1 dangerous fluids	Diagram 9 Group 2 no dangerous fluids
DON-05	1/8	400-	§4 Abs.3	§4 Abs.3
DON-10	1/4	400		
DON-15	1/4	400		
DON-20	1/2	400		

3. Instrument Inspection

Instruments are inspected before shipping and sent out in perfect condition.

Should damage to a device be visible, we recommend a thorough inspection of the delivery packaging. In case of damage, please inform your parcel service / forwarding agent immediately, since they are responsible for damages during transit.

Scope of delivery:

The standard delivery includes:

- Oval Wheel Flowmeter, High pressure model: DON-H...
- Operating Instructions

4. Regulation Use

The oval gear meter is a precise positive displacement flowmeter incorporating a pair of oval geared rotors. These meters are capable of measuring the flow of a broad range of clean liquids.

Stainless Steel flowmeters are suited to most water based products and chemicals and aluminium meters are suitable for fuels, fuel oils, & lubricating liquids. It is important to ensure that the medium to be measured is compatible with the materials used in the instrument (see section 10 "Technical Data"). It is also imperative to comply with the maximum permissible operating parameters specified in the "Technical Data" section.

The flowmeter is available as a measurement transducer with pulse output or with other forms of evaluation electronics. Details of how to operate the electronics are included in a separate instruction manual.

These flowmeters DON can be installed within hazardous areas by using the reed switch pulse output in intrinsically safe loops or installing intrinsically safe certified barriers.

Any use of the oval gear flow meter model: DON, which exceeds the manufacturer's specification, may invalidate its warranty. Therefore, any resulting damage is not the responsibility of the manufacturer. The user assumes all risk for such usage.

5. Operating Principle

Oval gear flowmeters are categorized as positive displacement flow technology. When liquid flows through this type of positive displacement flowmeter, two oval geared rotors measure a constant volume per rotation within a precisely machined measuring chamber. With each rotation, a constant volume of liquid is measured. The rotation of the oval gears is sensed via magnets embedded within the rotors. These magnets transmit a high resolution pulse output. The output signal can be process externally via a remote display controller or PLC or via a variety of output/display options available as accessories attached to the flowmeters.

The positive displacement flow technology allows for precise flow measurement of most clean liquids regardless of the media conductivity. Other liquid properties also have a minimal effect on the performance of this type of meter. Flow profile conditioning is not required as with alternative flow technology options making oval gear installations simple to install in tight spaces and at an economical price.

OPERATION:

Liquid travels around the crescent shaped chambers created by the rotational movement of the rotors

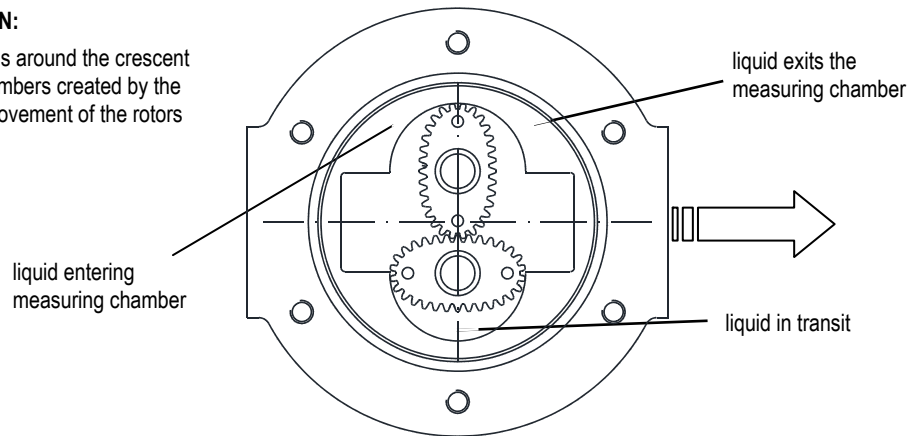

6. Mechanical Connection

6.1 General

Points to verify before meter installation:

- Chemical compatibility of the liquid. Be sure that all wetted parts are identified and confirmed suitable for use with the media being measured. If unsure, please contact a KOBOLD engineer for guidance in obtaining the proper reference materials.
- Verify that the operational pressure and temperature limits are within capability of the fully specified meter. Verify that the operational flow rates are within the specified flow range. Viscous liquids may limit the maximum allowable flow based on the viscosity. The max allowable flow rate may need to be limited to ensure the differential pressure across the flowmeter does not exceed 1 bar, (100 kPa, 15 PSIG).
- Be sure that the flowmeter is not subject to any process temperatures and/or pressures that can cause the measured liquid to freeze or flash inside the meter.
- the measuring instrument is not subjected to process temperatures and pressures that convert the liquid medium into a gas inside the device.

6.2 Orientation

When installing the flowmeter, orientation must be considered. The rotor shafts must be in a horizontal plane. To verify that the rotor shafts are in a horizontal plane, electronic cover or optional digital display will be facing in a horizontal direction. For modification in the field, the electronic cover or digital display can be rotated in any 90 degree position. This accommodates access to the electrical entry and allows the electronic display orientation to best suit the installation.

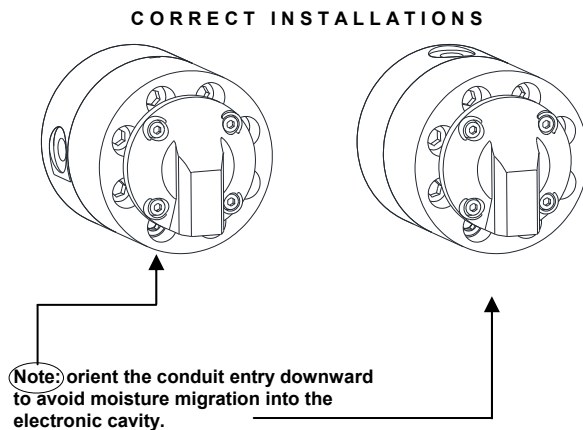
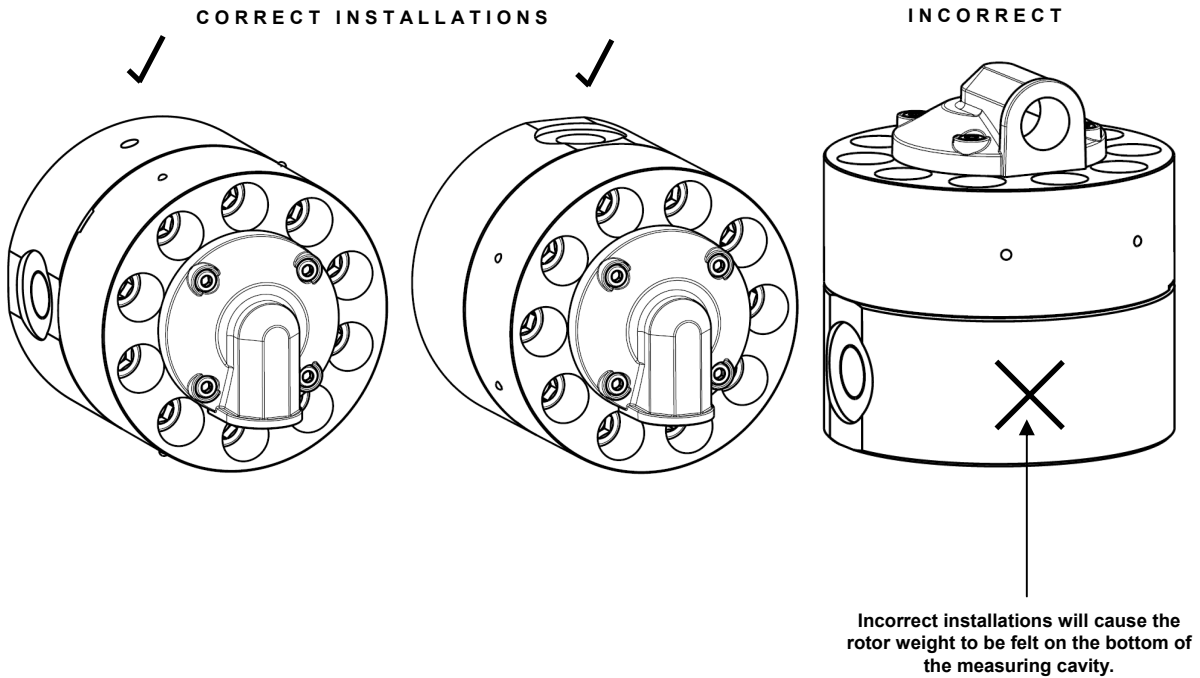

The DON flowmeter accommodates both horizontal and vertical flows. It is recommended that for vertical flow installations that the liquid flow up through the meter (*i.e. bottom to top*). This orientation assists in air or entrained gas removal. The flow meter is bidirectional. To identify the flow direction, in which the flowmeter was calibrated, the flowmeters are marked with arrows. These arrows are placed on the lower side for models DON-H05 .. DON-H20. The flowmeter calibration data refers to this arrow direction. This is also the preferred flow direction.

Flow Conditioning and installation location

Filter:

It is highly recommended to INSTALL a filter immediately before (prior to) the meter. Filters are available and sold separately.

Recommended Filter:

DON-H05...DON-H15: < 75 μm particle size (200 mesh)

DON-H20: < 150 μm particle size (100 mesh)

Flow conditioning: Flow conditions are not required since the DON flowmeter does not require any straight pipe runs before or after the flowmeter.

Location: The recommended installation would be before any flow control and/or shut off valves, this installation prevents complete emptying of the meter. This minimizes the risk of leakage and/or air entrapment which could result in damage to the flowmeter or inaccurate initial readings.

A by-pass installation is recommended for process or safety critical meters. Isolation valves enable the meter to be isolated from the system and serviced as needed. System purging is also possible with a by-pass arrangement. Accommodate all meter ratings and locate the meter on the discharge side of the process pump.

For outdoor applications, be sure all electrical entries are sealed properly via the proper glands, mounting, sealing or containment. For humid environments, mount the instrument appropriately as to avoid condensation build up. Generally these installations have the conduit connection pointing downward as to drain any condensate away from the electronics.

Liquid State: Liquid within the flowmeter must not freeze. If heat tracing is necessary, please be sure to adhere to the temperature limits of the flow meter. Ensure the liquid does not flash, do not exceed the max DP of the flowmeter.

Hydraulic shock: Surge dampeners or pressure relief valves must be installed if hydraulic shock or pressure spikes are present. Highly pulsating flow can also damage the DON flowmeter. Diaphragm pumps and specific application profiles can cause high frequency pulsating flow. Proper pulsating dampers are highly recommended.

7. Electrical Connection

7.1 Connecting Cable

Proper shielded instrument cable is highly recommended. Low capacitance twisted pair 7 x 0.3 mm (0.5 mm²) for use with the DON and any remote receiving instrumentation. Typical cable would be Belden® 9363 or similar. Connect the cable shield to DC common or designated grounding terminal at the receiving instrument. Remember to only connect the end of the cable shielding at the receiving instrument (not the DON) to ensure proper interference protection.

Please be sure not to run the connecting cable within a common conduit or in close proximity to conduit with high inductive loads or power sources. This could result in noise or inducted errors to the output signal or result in damage to the electronic components. Always run the instrument cables in a separate conduit or within a common conduit with other low power cables. Max cable length should be limited to 3280 ft (1000 m).

7.2 Hazardous area wiring

The instrument can only be operated in the ATEX area as “Simple Apparatus” in accordance with ATEX Article 1 §2 and 3 with the “Reed contact” (R0) option and without ATEX labelling. For this purpose, intrinsically safe cabling must be laid between the instrument, the hazardous area and an approved isolation switching unit outside the hazardous area. (See section 16 Manufacturers declaration – Switches for use in Explosive Atmospheres)

Alternatively, the device can be operated using option E1-E5 with Ex ia IIC T4 approval [see separate operating instructions]. Hall-effect sensor output is not possible if the DON flowmeter is operated in an ATEX zone as simple apparatus or using the E1-E5 option.

The wiring methods used must be in accordance with the applicable rules, provisions and requirements at the location where the device is installed. The measuring devices may only be connected by qualified personnel who are familiar with the protection classes, provisions and specifications for the device in areas at risk of explosion.

7.3 Electrical connection for integrated electronics options

The electrical connection of the integrated electronics options always requires the electronics cover to be dismantled. High pressure models incorporate the cable inlet into the electronics cover.

The connecting cable must be routed through the cable duct and connected in accordance with 7.3.1 to 7.3.4. The connecting terminals are of the plug-in type, and can be taken out of the terminal compartment to facilitate connection.

7.3.1 Hall-effect sensor with active pulse output (H0 option)

The H0 electronic option combines a hall-effect sensor with an active push-pull output stage. A three-phase electrical connection is used. The output is actively switched, either to the input terminal voltage +Vs or to GND. The external input terminal voltage is 8 to 30 V_{DC}. No additional external wiring is required (e.g. pull-up resistor). The high signal corresponds approximately to the +Vs input terminal voltage and the low signal approximately to 0 V.

The electrical load can be connected to either the input terminal voltage or GND

Max. output current (power source or sink): 100 mA (short-circuit protected).

The hall-effect sensor pulse output is not available if a device is ordered for use in the explosion hazard area as "Simple Apparatus" (e.g. if the "E1" option is ordered).



Note!

The electronic option H0 is available with reed switch output.

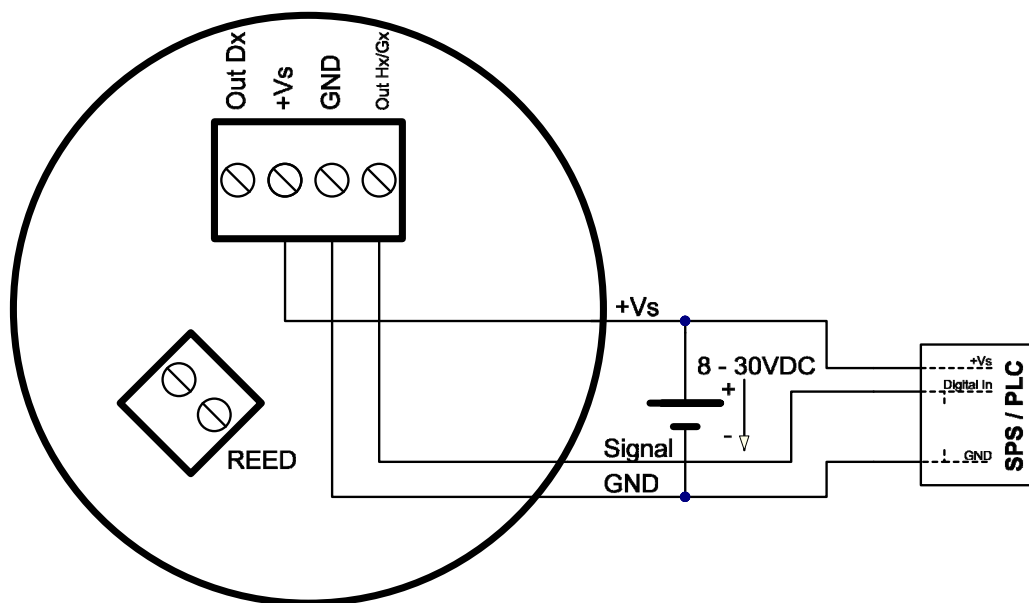

7.3.2 Reed Switch Pulse Output

The DON reed switch output is a SPST potential free N/O 2-wire output. This is a passive output so no power is required. The output may also be used with an appropriate intrinsically safe barrier for use in hazardous locations. If the intention is to operate the dry-reed contact impulse output in ATEX areas as simple apparatus, only the R0 option may be used. Note: when using the reed switch output the liquid temperature must not change at a rate greater than 10 °C per minute (50 °F per minute).

Average electrical endurance of switching contact (MTTF – Mean Time To First Failure):

Max. switching voltage (100 V/10 mA) 5×10^5 switching cycles

Max. current load (20 V/500 mA) 5×10^6 switching cycles

Min. load (<5 V/10 mA) 5×10^8 switching cycles

Switching capacity: Max. 30 V_{DC}, max. 200 mA

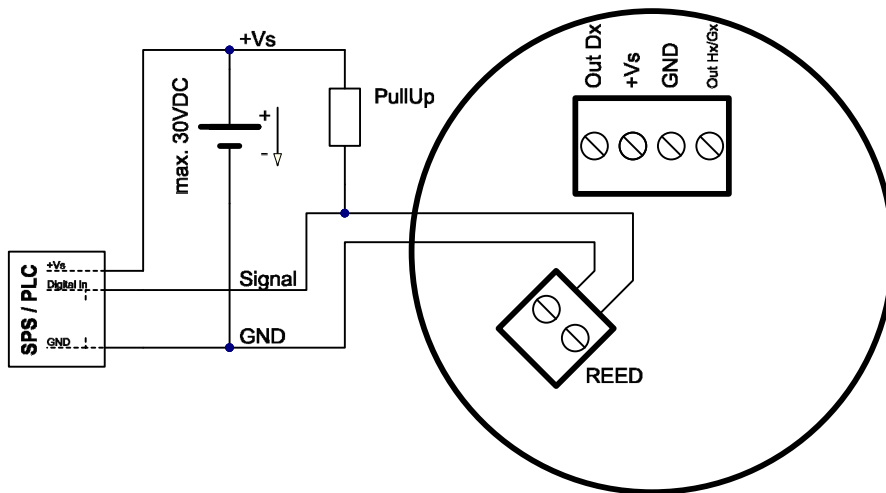

The individually specified maximum electrical values of the reed switch must never be exceeded, even for a moment. Higher switching values may reduce the service life or even destroy the contact.

For capacitive and inductive loads (e.g. via long lines), we recommend the following protective circuits:

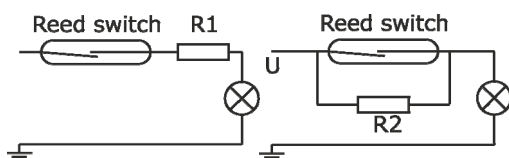

Lamp load with series or parallel resistance to the reed switch.

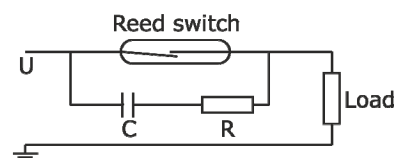

Protection with a RC suppressor
For a.c. current and inductive load.

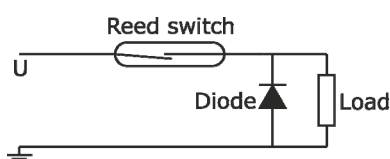

Protection with a diode
for d.c. current and inductive load.

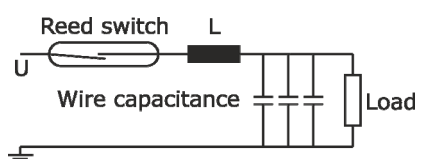

Protection with an inductance or
Resistance for capacitive load.

7.4 Internal wiring with electronic options –Ex/Zx

The Ex/Zx electronic options are pre-configured ex works in connection with the sensor boards. Reconfiguration is available on request.

7.4.1 For Z1/Z3 electronic options (reed switch and Hall sensor)

a) Wiring diagram with reed switch (ex works standard)

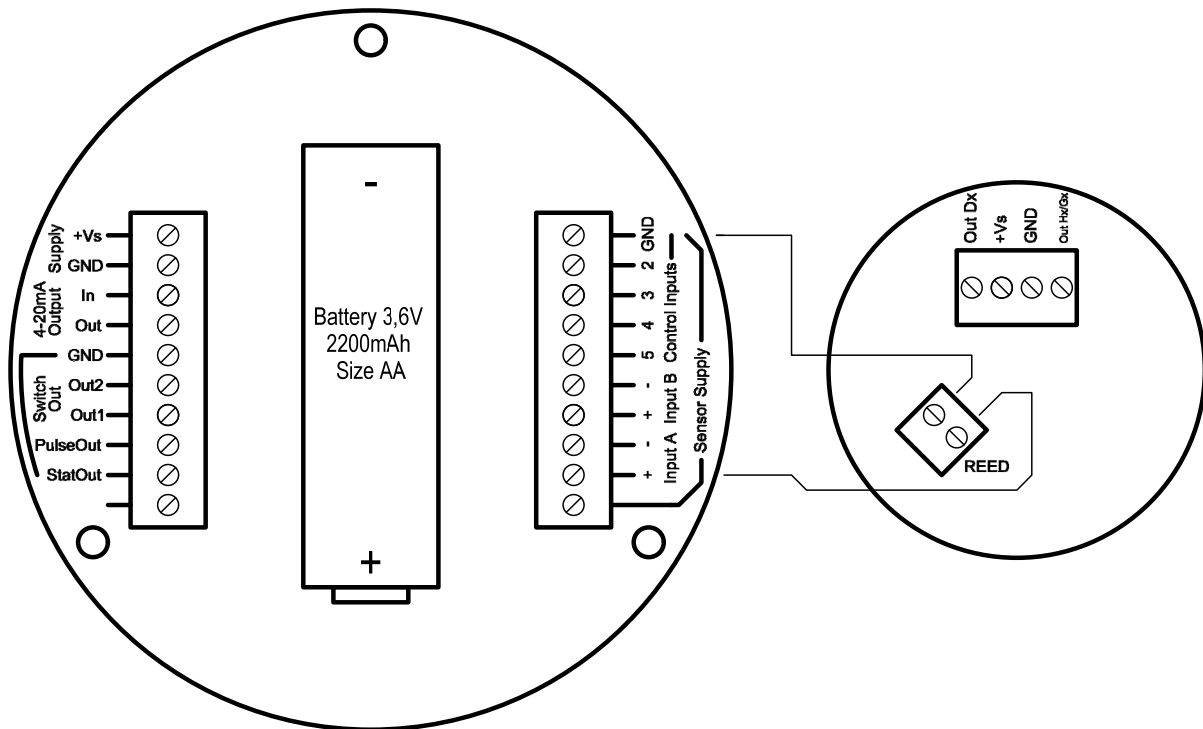

b) Wiring diagram with Hall sensor (recommended in connection with external supply)

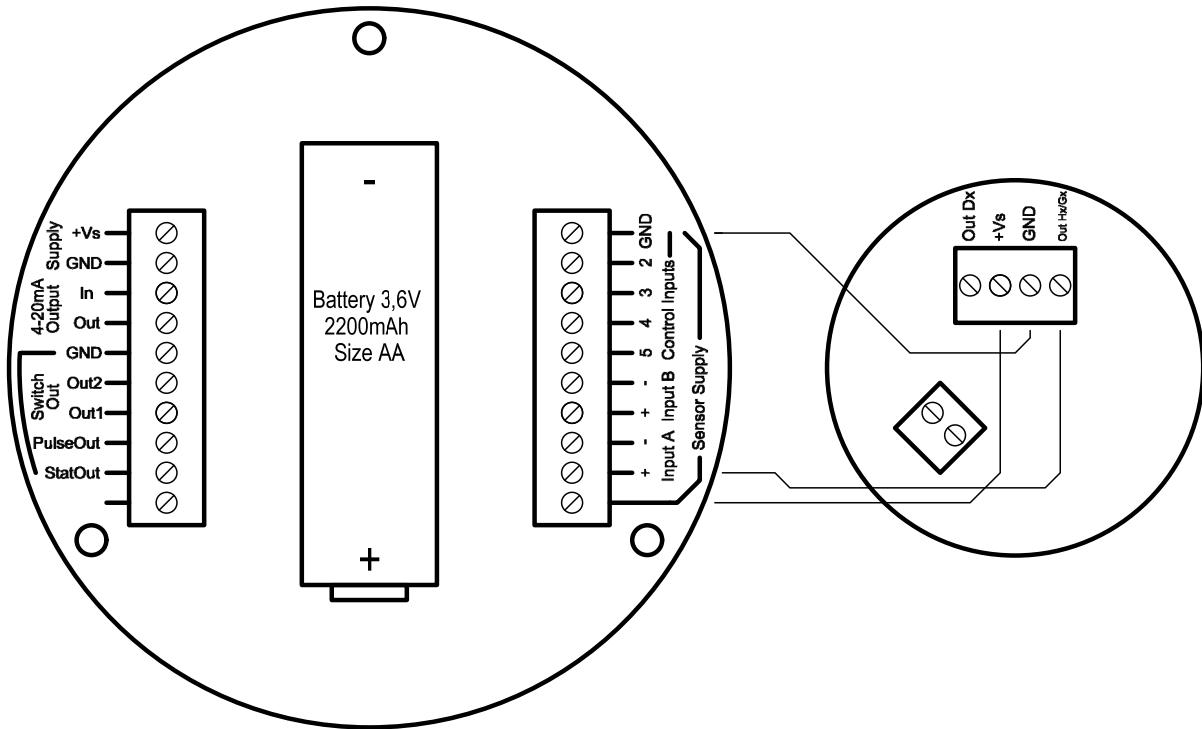

7.4.2 For E1/E3 electronics options

The wiring is exclusively implemented with a reed switch (see 7.4.1.a). Within this wiring, the reed switch operates as simple apparatus and may be used in Zone 1.

7.4.3 Calibration Factor (scale or K Factor)

The DON flowmeter is delivered with a factory calibration certificate. Within this certificate, a calibration factor is provided. The calibration factor is a specific representation of pulses per unit volume. (i.e. pulses per liter) for that specific meter.

Measurement devices with attached electronics are factory pre-configured to the corresponding calibration factor. Depending on the model, the calibration protocol is based on either the flow rate display or the analog output.

Please reference the appropriate digital display manual for programming details.

7.5 External wiring with electronic unit ZOK-Zx

7.5.1 Wiring with ZOK-ZxK

a) Circuit with Hall sensor (not for battery operation)

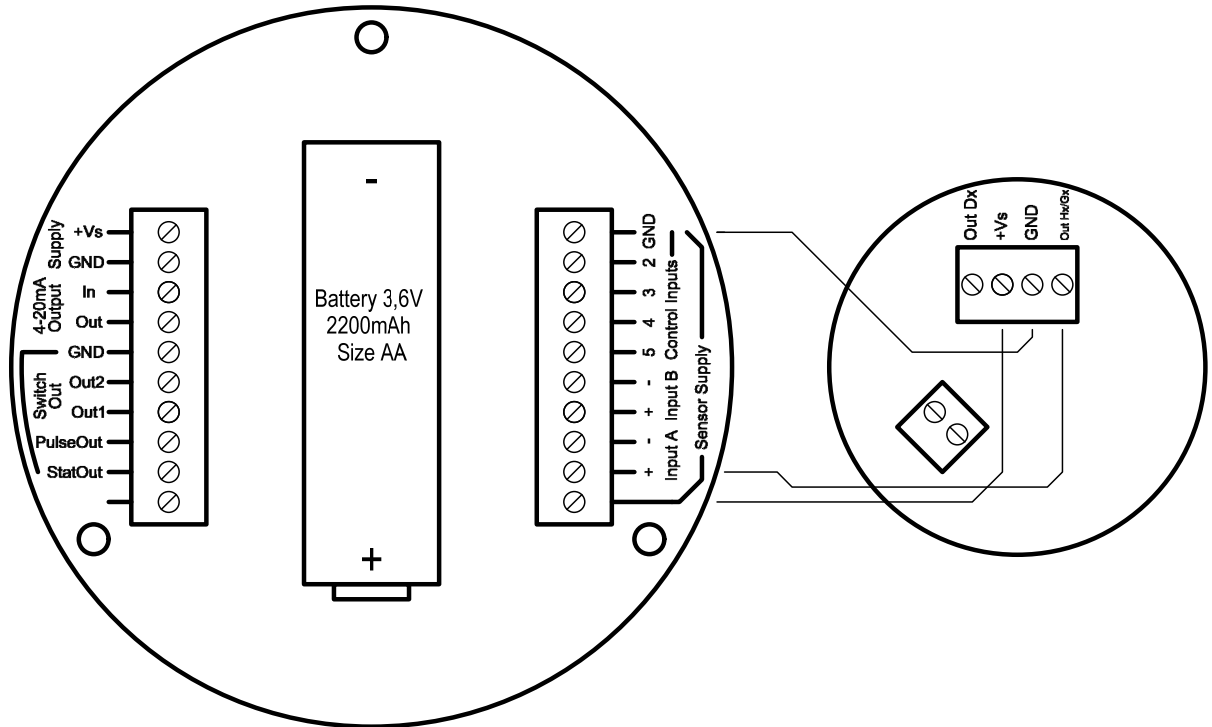

b) Circuit with Reed switch

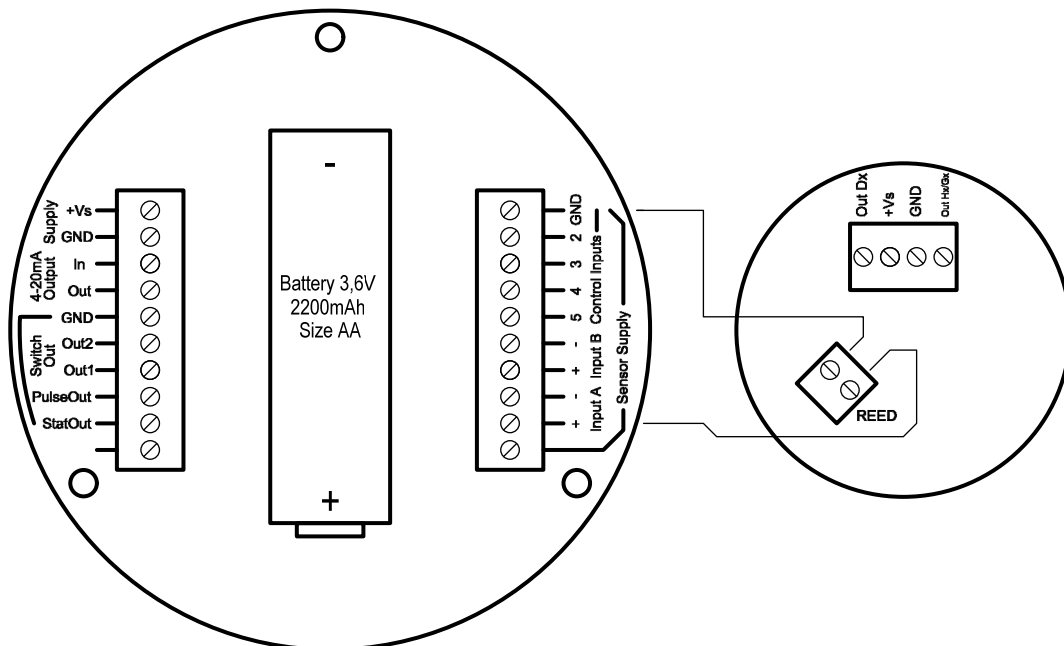

7.5.2 Wiring with ZOK-ZxP

a) Circuit with Hall sensor

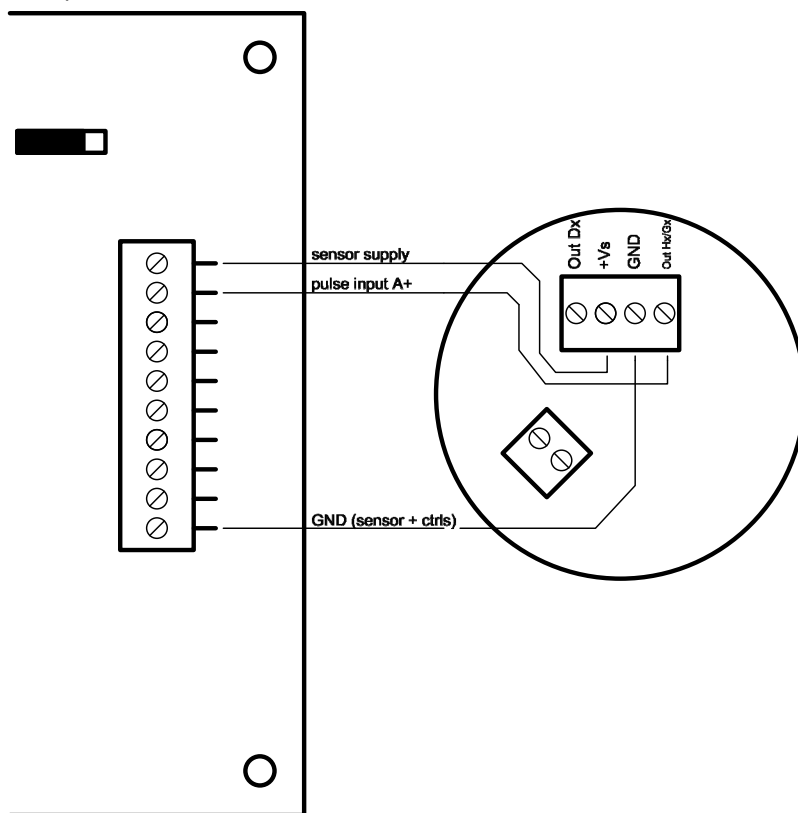

b) Circuit with Reed switch

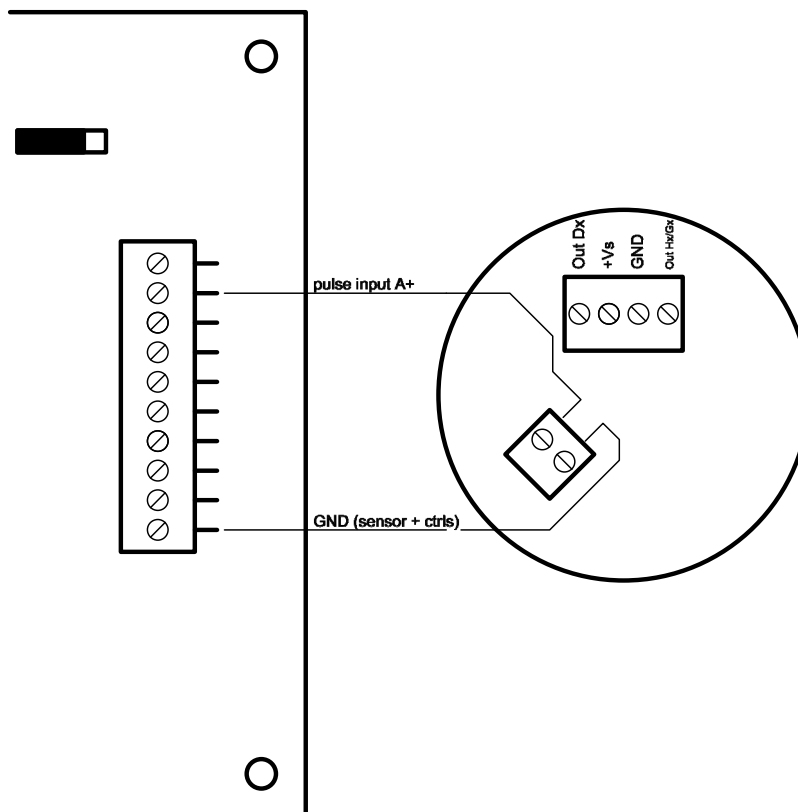

8. Commissioning

The piping **MUST** be flushed of debris before installation. Debris such as slag from welding, grinding dust, rust, pipe tape or sealing compound are common within new piping installations and will damage the flowmeter if not flushed or filtered from the process piping before installation and operation.

A by-pass system is common for frequent system flushing or frequent meter removal. If a by-pass system is not practical or possible, removal of the gears before flushing is necessary. (refer to section 9.1 “Disassembly of Pulse meter”).

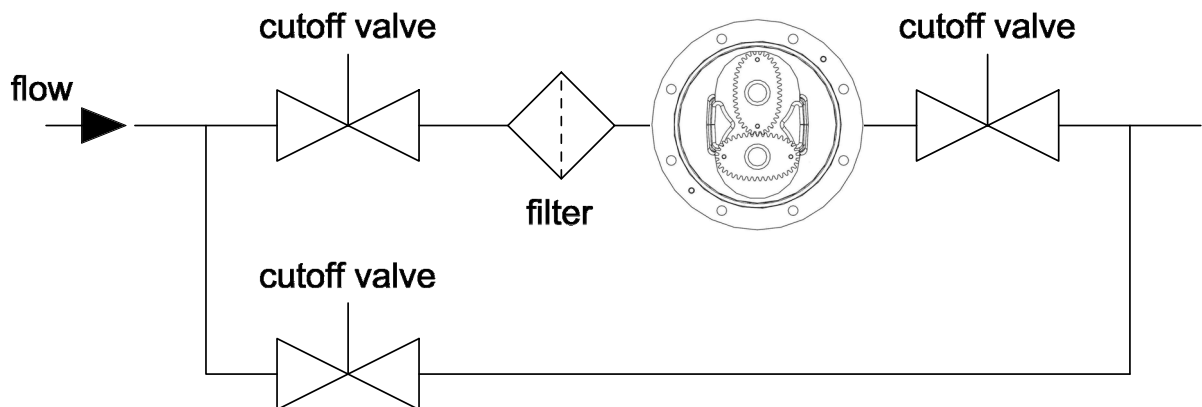

For proper operation the flowmeter must be purged of air. During long periods of inactivity or after a flushing, air may be in the piping. Elimination of the air may be achieved by operating the meter at a low flow rate until all the air is eliminated. Damage may occur to the flowmeter if it is run above the maximum rated flow rate or if the maximum differential pressure of 15 psi (1 bar, 100 kPa) is exceeded.

After mechanical and electrical installation according to the guidelines set forth within this user manual, the DON flowmeter is ready for operation.



Warning!

Risk of damage by blocking of measuring mechanism. A missing count signal may indicate a blocked measuring mechanism. The resulting increase in pressure before the device can lead to further damage to the unit and / or the plant. Remove the unit or shut down the plant immediately, if an unplanned absence of the counter signal takes place. Eliminate the cause of the malfunction.

9. Maintenance

Flowmeter maintenance precautions:

- Remove/disconnect power to the flowmeter.
- Ensure that flow supply to the meter is turned off and the system is not under pressure.
- Completely drain the flowmeter
- Confirm that any signal output(s) will not affect the system when de-energized or removed from the circuit.

Oval gear positive displacement flowmeters are mechanical by nature. A periodic maintenance/inspection schedule is suggested for an extended service life. Follow the guidelines within this user manual for the maximum flowmeter performance.

The maintenance/inspection schedule should be determined based off of application factors such as media type (abrasiveness, lubricity, and/or chemical compatibility), flow rate, and operating/maximum temperature and pressure.

9.1 Disassembly of DON-H with Pulse meter

Concerning options H0 and R0

9.1.1 Pulse output board removal (refer exploded view diagram)

To remove the pulse output board, remove the 4 electronic cover screws (10), and remove the electronic cover (9). The pulse output board (6) can now be accessed and removed via the removal of the electronic board screws (7).

9.1.2 Oval gear removal for DON-H05...DON-H10 (refer exploded view diagram)

For access to the oval gears, remove the 4 lower meter body screws (5). With care, remove the upper meter body assembly (4) being careful not to damage or misplace the O-ring (3). You can then remove the oval gears (2).

For these small flowmeters (4 mm & 6 mm), when disassembling, please notice the dimples located on the meter bodies (1 & 4) face just outside the o-ring groove. The referencing dimples must be in alignment when reassembling.

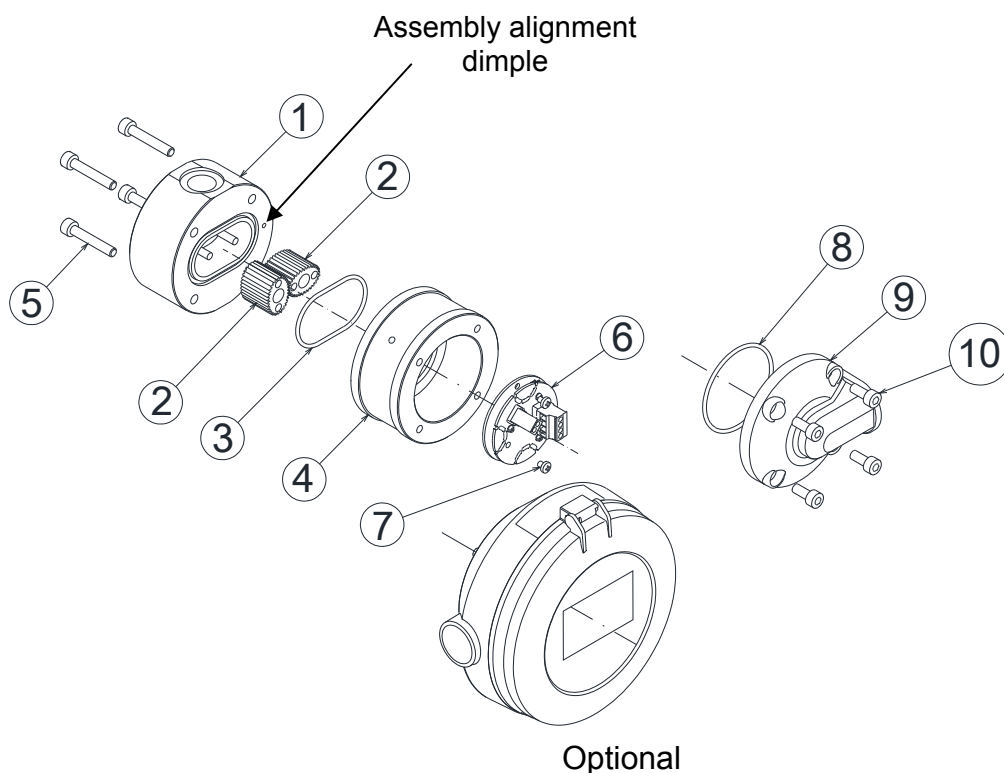

DON-H

9.1.3 Removal of oval gears for DON-H15...H20 (refer exploded view)

For access to the oval gears, remove the 8 or 10 upper meter body screws (5). With care, remove the upper meter body assembly (4) being careful not to damage or misplace the O-ring (3). You can then remove the oval gears (2).

DON-H15...

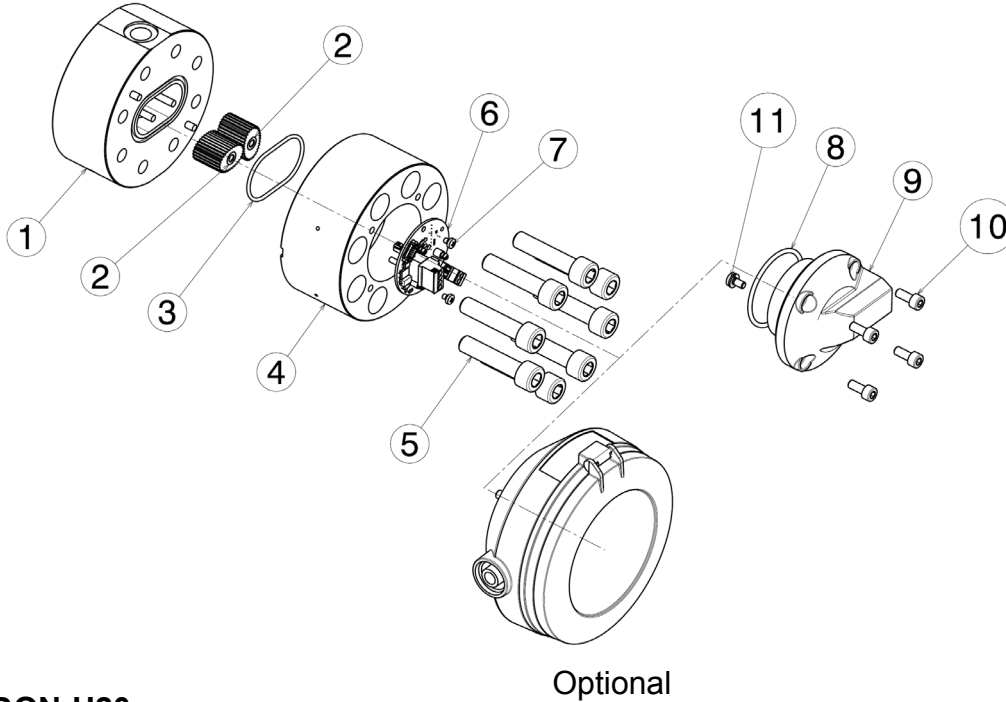

DON-H20...

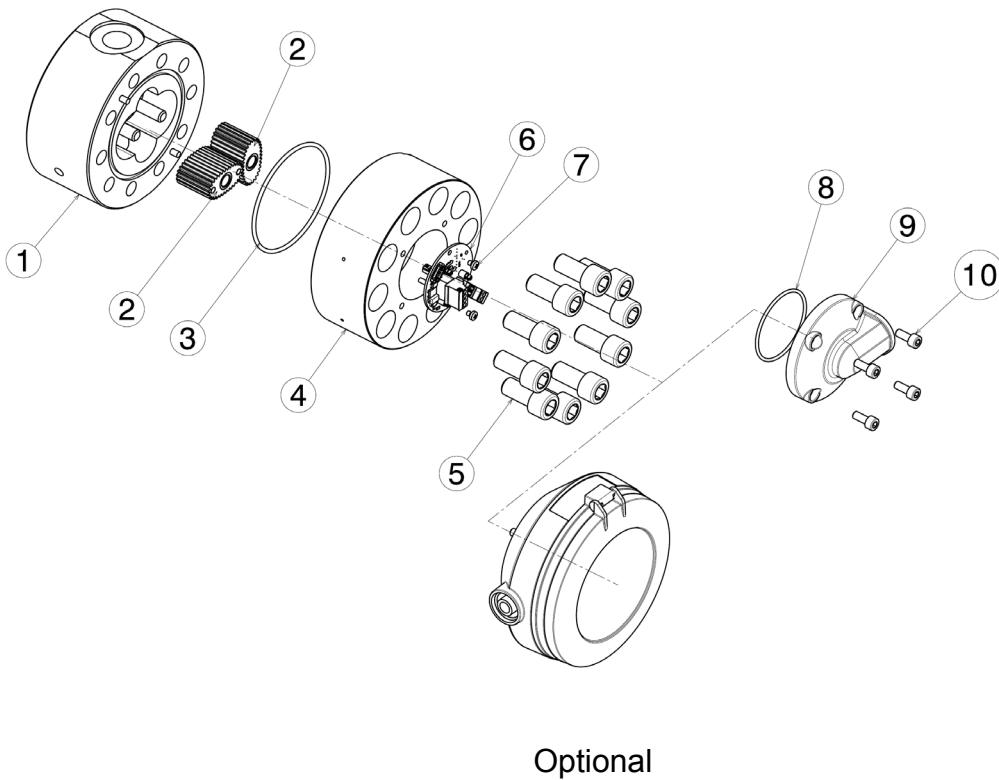

9.2 Demounting of the electronics mounted on a DON with Zx and Ex options

To access the device battery, terminal connections and pulse output board, the electronic cover with display must first be removed in case of flowmeters with built-in electronics. To do this, loosen the 4 screws of the display cover and carefully remove it without pulling out or damaging the connecting cable. During this procedure, be careful not to lose or damage the O ring. The terminal connection, device battery and pulse output board are now freely accessible. To remove the electronics, the screws used to connect the electronics housing to the oval gearbox housing should be loosened.

9.3 Spare Parts

Please consult your closest KOBOLD-Office
Internet: www.kobold.com or www.koboldusa.com

9.4 Inspection (refer Exploded View)

Inspection points will be the following:

O-rings – Inspect for physical or chemical damage or deformation.

Rotors – Inspect for physical damage due to unfiltered media or damage due to chemical attack. Also observe also the magnets, if exposed, for chemical attack.

Measuring Cavity – Inspect for physical damage (scoring) due to improperly filtered media or long term wear and tear.

Axle Shafts – Inspect for physical damage and ensure that the shafts are not loose and do not rotate.

9.5 Re-assembly of DON-H

Before re-assembly, please be sure to thoroughly clean all parts.

Care must be taken when reinstalling the rotors such that the magnets should face the pulse output board.

9.5.1 Re-assembly of DON-H05...DON-H10

For DON-H models DON-H05 to DON-H10, when re-assembling, please insert the rotor with the embedded magnet nearest to the dimple located on the meter body face just outside the o-ring groove. Install the rotors exactly perpendicular from each other (90° in orientation). They will only work if installed precisely. Manually test full rotation after installation as the rotors will not completely rotate freely unless installed precisely 90° from each other.

Proper placement of the O-ring within the groove is necessary for leak free operation. After placement, items (1 & 4) will then require assembly. For the flowmeters, reference the alignment dimples on the lower meter body and upper meter body (1 & 4) for proper assembly.

Tighten the meter bodies (1 & 4) with the screws (5) in an alternating pattern (1, 3, 2, 4). Tighten to each to a torque of 3.5 Nm. The alternating tightening procedure is preferred for proper and even assembly.

Install the pulse output board, the o-ring into the provided groove, and then install either the pulse output board cover (9) or optional electronic assembly.

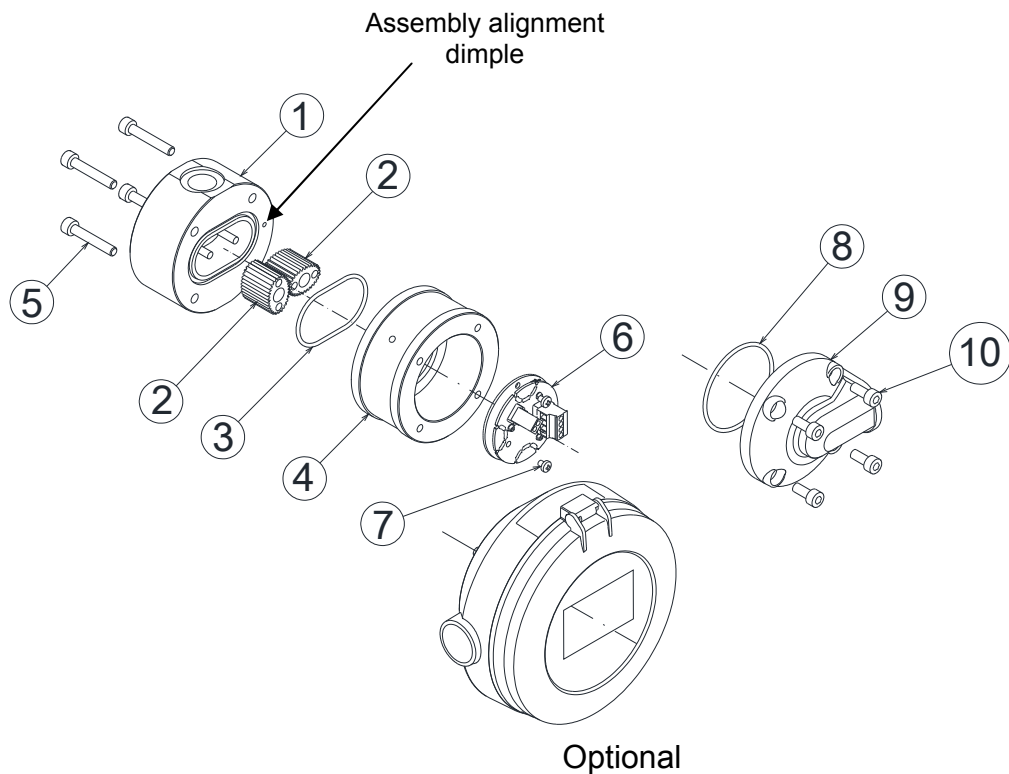

9.5.2 Re-assembly of DON-H15...DON-H20

Both oval gears are placed on the axle shafts with the magnets oriented towards the upper meter body (4). Verify that the axle shafts are not loose. Both oval gears are equipped with embedded magnets, allowing them to each be mounted on either axle.

Install the rotors exactly perpendicular from each other (90° in orientation). They will only work if installed precisely. Manually test full rotation after installation as the rotors will not completely rotate freely unless installed precisely 90° from each other.

Proper placement of the O-ring within the groove is necessary for leak free operation. After placement, items (1 & 4) will then require assembly.

Tighten the upper meter body to the lower meter body (1 & 4) with the screws (5) in an alternating pattern (1, 3, 2, 4). Tighten to each to a torque of 3.5 Nm. The alternating tightening procedure is preferred for proper and even assembly.

Install the pulse detector board, the o-ring into the provided groove, and then install either the electronic cover (9) or optional electronic assembly.

Exploded view of DON-H15...DON-H20

DON-H15...

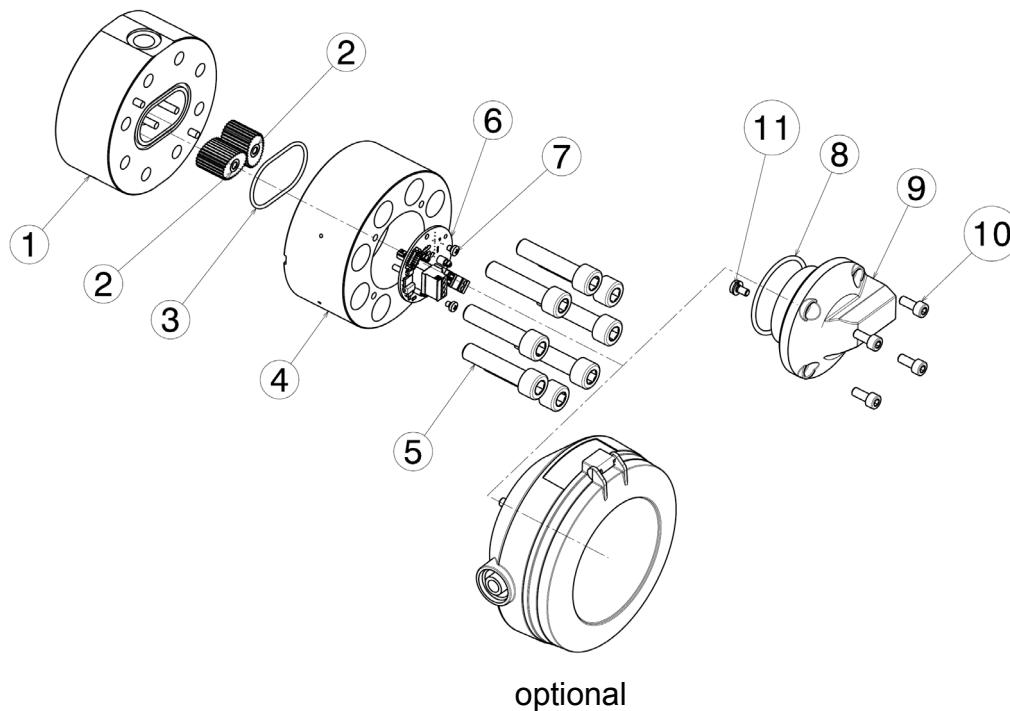

DON-H

DON-H20...

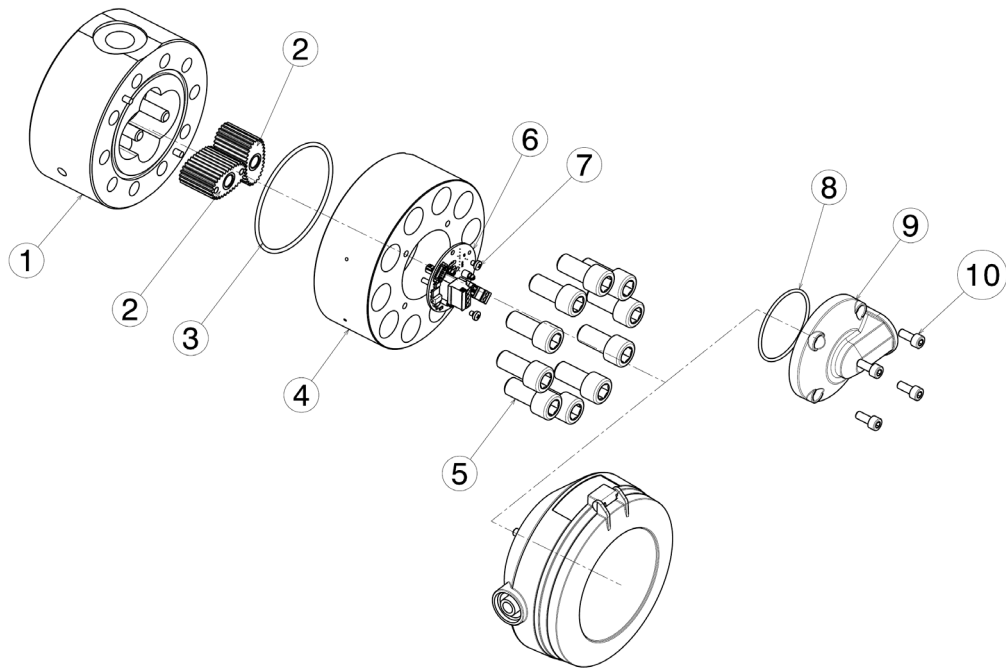

Optional

10. Technical Data

Material:

Body: stainl. Steel 1.4404 DON-H05...DON-H20
 Oval wheels: stainl. Steel 1.4404 DON-H05...DON-H20
 Bearing: carbon graphite
 Axes: stainl. Steel 1.4404

O-Rings: medium temperature
 FKM: -20..+120 °C
 NBR: -20..+100 °C
 FEP-O-seal/FKM: -15...+130 °C
 Cover for cable connection: polyamide PA6 GF35 UL94 HB/VO
 stainless steel 1.4404

Accuracy
 (under reference conditions*): ± 1 % of reading (DON-H05..DON-H15)
 SS rotors: ± 0.5 % of reading (DON-H20)
 with optional Z3/E3-electronics based on
 linearization function

Protection class: IP 66/67
 Medium temperature: -20 °C...+120 °C for pulse output
 and options Z with cooling fins

Ambient temperature: -20...+80 °C
 Cable entry: M20x1.5, ½" NPT

ATEX approval
 (option E1-E5):  II 2G Ex ia IIC T4 Gb (-20 °C...+60 °C)

* Reference conditions: H05...H20 (mineral oil 10 cSt, 20 °C, 5 bar);
 Accuracy data is valid for given viscosities and higher

DON-H

R0 electronics options:
(Reed switch pulse output)

max. switching voltage: 30 V_{DC}
max. switching current: 200 mA
max. switching capacity: 10 W
Service life: > 2*10⁶ switching cycles
(at 5 V_{DC} and 10 mA)

H0 electronics options:
(Hall sensor + reed switch pulse output)

Supply voltage: 8 to 30 V_{DC}
Supply current: max. 5 mA (without load)
Hall pulse output: active push-pull, max. 100 mA, short-circuit-proof
HIGH level: Min. +Vs – 1.3 V
LOW level: max. 1.3 V
Reed pulse output: as for R0/RE

Z1/Z2/Z3 electronics options (common properties):

Supply voltage: 8 to 32 V_{DC}
Battery operation (only Z1/Z3)
Battery: 3.6 V/2200 mA AA size
Display: LCD, graphic 128x64
Backlighting adjustable
Operation: 4 buttons
Housing: plastic, PA6, GF-reinforced
Cable inlet: 3x M20x1.5, prepared
Electrical connection: plug-in terminals

Z1 electronics option:
(Dual counter)

Signal inputs: 2x, configurable
Daily/overall counter: 1x per input
Signal outputs: none

Z2 electronics option:
(Batching device)

Signal inputs: 1x, configurable
Batching function: 2-stage
Signal outputs: relay output

Z3 electronics option:
(Flow controller)

Signal inputs: 2x, configurable
Signal outputs: current output 4-20 mA
2-wire / 3-wire pulse output, scalable status output
Max. working resistance of current output: 750 ohms (at 24V_{DC})

Maximum Pressure (threaded version)

DON-H05...-20: 400 bar

Max. Flowrate Multiplier (for higher viscosities)

Viscosities (cP)	Standard rotor	Special cut rotor
≤ 1000	1	1
≤ 2000	0,5	1
≤ 4000	0,42	0,84
≤ 6000	0,33	0,66
≤ 8000	0,25	0,5
≤ 30000	0,15	0,3
≤ 60000	0,12	0,25
≤ 150000	0,1	0,2
≤ 250000	0,05	0,1
≤1000000	0,025	0,05

Special cut rotors for higher viscosities

For viscosity > 1000 cP, special cut rotors option „S“ should be used to reduce pressure drop. This applies to DON-H15 and larger sizes. For higher viscosities, the flowmeter max. flowrate is de-rated according to the attached chart.

Example: DON-H20 measuring oil at 8 000 cP, max. flow 150 LPM x 0.5 = 75 LPM new maximum flow rate.

Output Pulse Resolution

Model	Measuring range [L/min]	Pulse / litre	
		Reedswitch Rx	Hall sensor Hx
DON-H05	0,5 - 36 L/h	2670	2670
DON-H06	2-36 L/h	2670	2670
DON-H10	2 - 100 L/h	1054	1054
DON-H15	15 – 550 L/h	355	710
DON-H20	1-40	82	163

The values in above mentioned table are only approximate guidelines. The actual value for pulse rate can deviate from the values in this table and is mentioned in calibration certificate delivered with the flowmeter.

11. Pressure drop curves

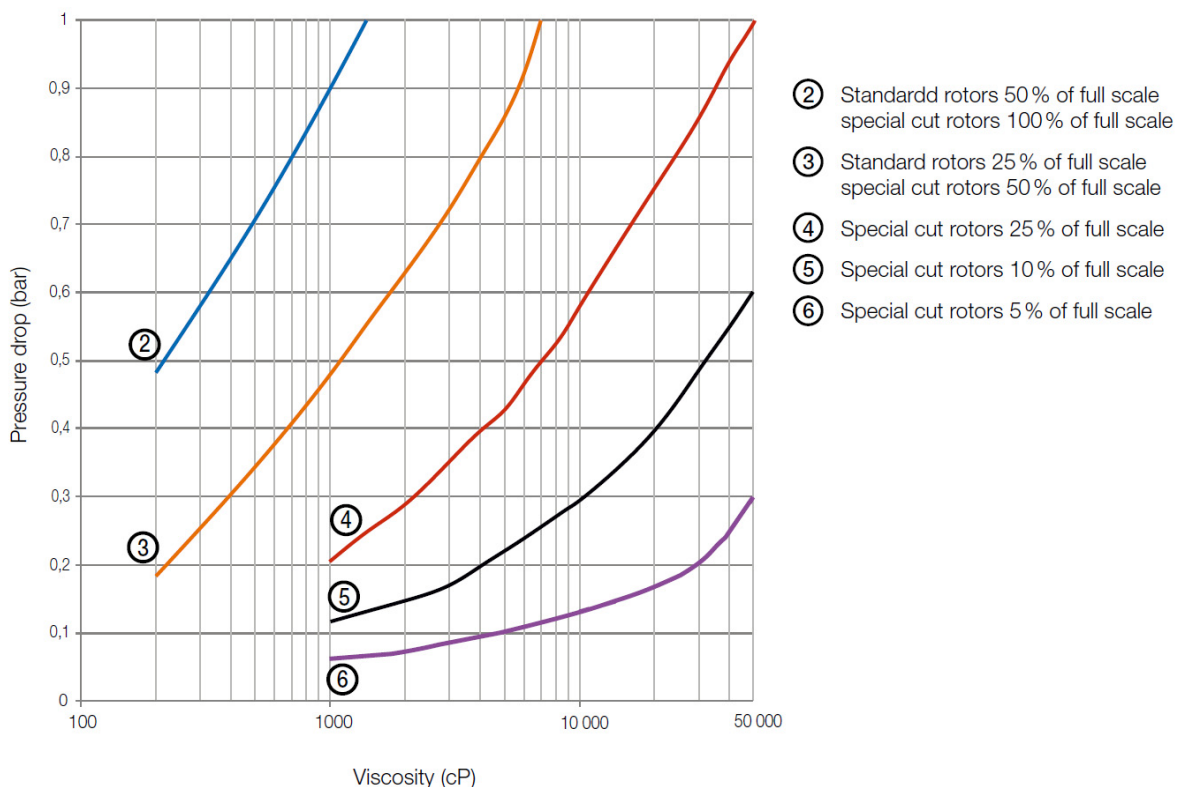
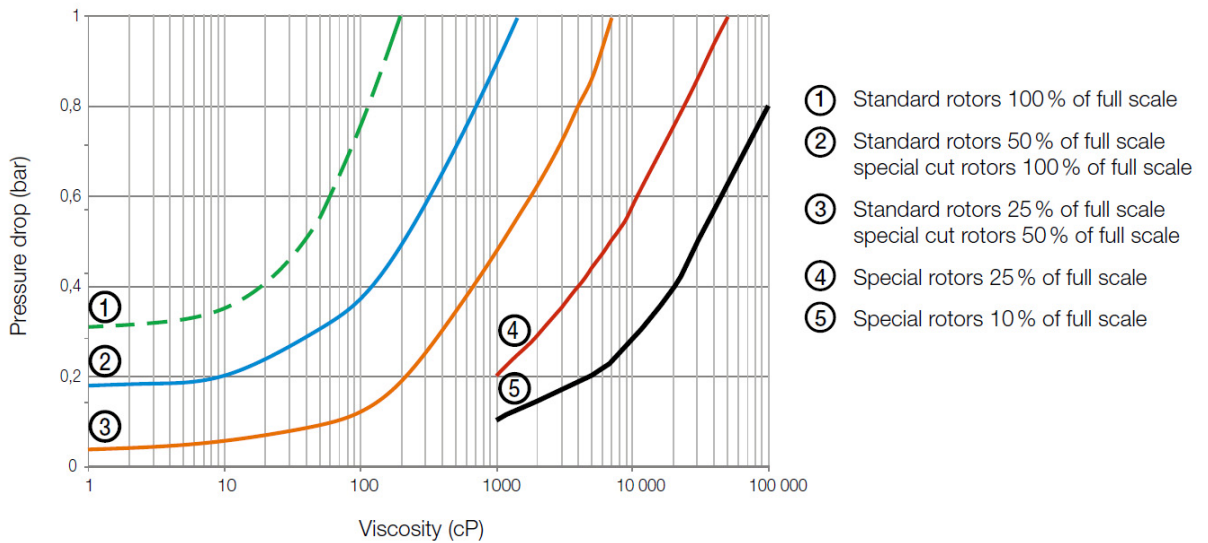

Pressure drop limit versus flowrate

The curves above represent the pressure drop for standard cut oval rotors. Special cut rotors option «Y» have alternate tooth relieve which effectively reduces the pressure drop by 50%. When sizing a meter, be sure your selection falls below the 1 bar maximum allowable pressure drop line on the graph.

12. Order codes

Example: DON-H10H R1 1 R0 M 0

Measuring range [l/min]	Housing material ²⁾ Stainless steel	Connection	O-Ring Material	Electronics	Cable entry	Option
0.5 – 36 l/h	DON-H05H ¹⁾	R1 = G 1/8 N1 = 1/8" NPT	1 = FKM 3 = FEP- O-ring 4 = NBR	R0 = Reed switch pulse output H0 = hall sensor (Push-Pull)/ reed switch, pulse output Z1 = dual LCD totalizer Z2 = Dosing unit LCD Z3 = LCD totalizer/rate, outputs: 4-20 mA, alarm, pulse (ZOK-Z3) (impulses not for battery supply) E1 ⁵⁾ = Z1 + ATEX (Exi) E2 ¹⁾⁵⁾ = Z2 + ATEX (Exi) E3 ⁵⁾ = Z3 + ATEX (Exi) without switching or pulse outputs E4 ¹⁾⁵⁾ = E3 + HART E5 ⁵⁾ = E3 + pulse or switching outputs without 4-20 mA	M = M20 N = 1/2" NPT S ³⁾ = M20 + cooling fin T ³⁾ = 1/2" NPT + cooling fin	0 = without Y ⁴⁾ = special cut rotors for higher viscosities Y = special option, (specify in clear text) e.g.
2-36 l/h	DON-H06H ¹⁾	R1 = G 1/8 N1 = 1/8" NPT				
2 – 100 l/h	DON-H10H	R2 = G 1/4 N2 = 1/4" NPT				
15 – 550 l/h	DON-H15H	R2 = G 1/4 N2 = 1/4" NPT				
1 – 40	DON-H20H	R4 = G 1/2 N4 = 1/2" NPT				

¹⁾ in preparation ²⁾ Replace 'H' with 'G' to order GPH (GPM) (e.g. 15 G instead 15 H) ³⁾ Only for electronic options -Zx

⁴⁾ Not for DON-H05...DON-H10 ⁶⁾ Without backlighting

13. Dimensions Electronic Options Ex/Zx

Option -M/-N (standard)

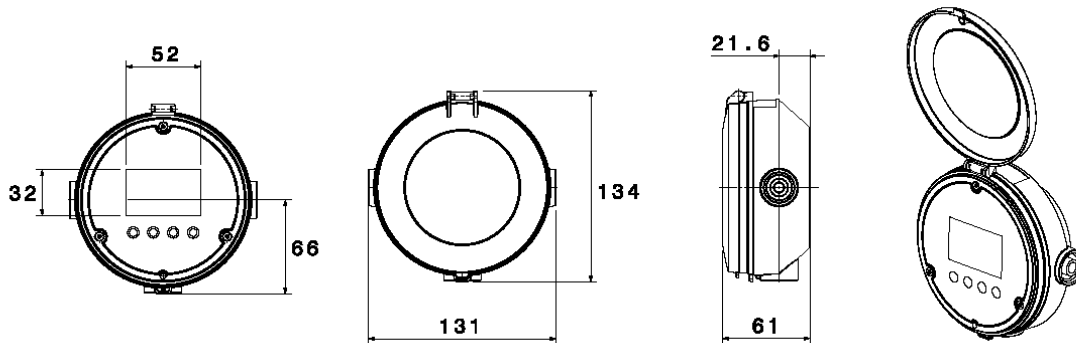

Option -S/-T (with cooling fin)

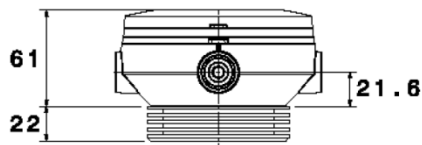

14. Troubleshooting

Oval gear flowmeters have two clearly distinct portions: one of which is mechanical, wetted areas with the oval gears surrounded by a housing, and the other is the electrical area, which includes the pulse output board.

Details of some key troubleshooting steps will now be provided. Please also refer to the instructions on troubleshooting errors contained on the following page.

Step 1 - Check application, installation and set-up.

Carefully read the section on mechanical installation to ensure full knowledge of all relevant installation and application factors which may affect the operation of the counter. These include pulsation, trapped air or selecting the wrong counter, including incorrect flow rate, temperature or pressure, or material incompatibility. Refer to the section on electrical installation to ensure correct cabling.

Step 2 - Check for blockages.

For new and modified systems in particular, the most frequent cause of error or sub-optimal counter operation is internal system or counter blockages due to foreign particles, such as beads of condensate, sealing tape residues or mixtures of deposits, rust, etc.

Step 3 - Guarantee flow rate.

Flow stopping or a flow rate declining below the usual limit may be attributable to a blocked screen, flowmeter rotors which are stuck or damaged, a defective pump, closed valves or an insufficient liquid level in the storage tank.

Step 4 - The oval gears in the counter must revolve.

This rotation is audible: try holding a screwdriver blade against the counter housing and push the handle right against your earlobe. Test the counter as required with flow switched on and off, to ensure you are familiar with the audible sound of rotation.

Step 5 - Ensure that pulses are generated when liquids flow.

Here, a multimeter is often not fast enough to capture the pulse sequence of the reed switch or the Hall Effect sensor. However, an oscilloscope will allow you to observe the output pulse sequence. When testing the reed switch pulse, a pull-up resistor must be installed between the single connection of the reed switch and the supply voltage, while the other connection must be connected to the reference potential of the measurement device (oscilloscope) (see electrical installation).

Step 6 - Confirm device operation.

If a mounted electronic component is connected to the DON, check the functions by simulating a pulse input. A reed switch pulse input can be simulated by a swift and pulse-driven short-circuiting of the input terminals.

Problem	Possible cause	Solution
Counter values too high	1. Disruption of the output signal	1. Ground shielding of the signal cable
		2. Re-lay the cable away from sources of high current
	2. Air or gas pockets	1. Eliminate the source of the air or gas pocket
		2. Install an upstream air separator
	3. Pulsating flow from the piston pump	1. Increase back-pressure to the pump
		2. Install a quick-response one-way check valve
3. Install a pulsation damper between the pump and the counter		
4. Recalibrate the counter on site, to compensate for pulsations		
Counter values are too low	1. Damaged or worn rotors	1. Check, repair, clear or replace rotors
	2. Damaged or worn measurement chamber	1. Check measurement chamber for damage - repair as required
		2. Check concentricity of the rotor shafts in the chamber
	3. Disruption of the output signal	1. Ground shielding of the signal cable
		2. Re-lay the cable away from sources of high current
No output from counter	1. Soiled rotors	1. Check whether the rounded teeth at the base of the chamber are visible
		2. Check for any obstructing foreign particles
		3. Clear, repair or replace rotors
	2. Counter incorrectly mounted	1. See instructions for re-mounting the counter, focusing on the positioning of rotors and magnets above all
	3. No output from the output board	1. Check screw terminal connections and soldering joints
		2. Ensure the presence of DC voltage at +Vs and 0V/GND and that the analytical electronics connected include a pull-up resistor when using the reed switch
3. Replace output plate		
No flow signals indicated on the analytical device	1. Defective analytical electronics	1. Check settings and parameter data in the set-up menu
		2. Check screw terminal connections and the presence of electrical current
		3. Repair/replace analytical electronics

DON-H

Each DON volume counter has been calibrated to function with mineral oil, which means the remainder of the calibration oil still remains in the device.

The oil used

for measurement ranges X05 to X20: SHELL Morlina 10

15. EU Declaration of Conformance

We, KOBOLD Messring GmbH, Hofheim-Ts, Germany, declare under our sole responsibility that the product:

Oval Gear Flow Meter Model: DON-H...

to which this declaration relates is in conformity with the directives noted below:

2014/68/EU PED

2011/65/EU RoHS

All devices with electronic are in conformance with:

2012/19/EU WEEE (Waste Electrical & Electronic Equipment)

2014/30/EU EMC Directive

EN 61326-1:2013 Electrical equipment for measurement, control and laboratory use - EMC requirements – Part 1: General requirements

The technical requirements of these standards are in accordance with the requirements of the harmonized standards EN 60079-0:2012 and EN 60079-1:2007, where no differences appeared that would affect the latest technical standards of our products subscribed to this declaration.



H. Peters
General Manager



M. Wenzel
Proxy Holder

Hofheim, 02. March 2017

16. Manufacturers declaration – Switches for use in Explosive Atmospheres

Background

a) Simple apparatus such as Mechanical contact switches, Reed switches, Thermocouples, Resistive sensors & LED's may be employed in a hazardous area without certification provided that the device does not generate or store more than 1.2 V, 0.1 A, 20 μ J and 25 mW. This IEC definition is also now used in the USA & Canada.

b) The surface temperature of simple apparatus under normal or fault conditions must not exceed the ignition temperature of the gas, subject to the following very valuable exception.

c) Because the ability of hot surfaces to cause ignition depends on their size, simple apparatus having a surface area between 20 mm² and 100 mm² will be classified T4 when the matched output power of the interface device does not exceed:

- 1.3W into 40 °C ambient
- 1.2W into 60 °C ambient
- 1.0W into 80 °C ambient

The 1.3 W / 40 °C element of this European dispensation is now accepted in the USA and Canada. Switches (mechanical & reed switches) and junction boxes dissipate no power and are normally classified T6 (85 °C).

These simple apparatus can be installed freely in I.S. circuits, no certification is required.

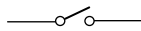

Reed switch



Thermocouples



Resistive sensors

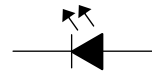

LED

Declaration

We, Kobold Messring GmbH, hereby declare that the reed contacts installed in the H0 and R0 DON electronics options come within the scope of "Simple Apparatus" pursuant to European, American and Canadian guidelines, although no special labelling is included to this effect.

Hofheim, 02. March 2017

H. Peters
General Manager

M. Wenzel
Proxy Holder

17. State of safeness

	State of safeness KOBOLD Messring GmbH, D-65719 Hofheim	FO41903E Rev. 02/15
<u>Explanation for our customers:</u>		
In case of returning please take into account the following details and enclose this state of safeness		
Address of the customer:		
Contact person:		
E-Mail-Address:		
KOBOLD-Product:		
KOBOLD- Order No.:		
<hr/>		
<u>To be completed by customer</u>		
<ul style="list-style-type: none"> • Description of defect: 		
kind of medium:		
trade name:	supplier:	<hr/>
<ul style="list-style-type: none"> • Operation conditions: 		
temperature: _____ °C		
pressure: _____ bar		
flow rate: _____		
<hr/>		
<ul style="list-style-type: none"> • Statement of safeness 		
We hereby certify that there are no noxious substances whatsoever (including detergents) in the instruments returned and that there is no hazard to employees handling the instruments.		
<hr/> Stamp, date, signature		