

Smart Solutions. Powerful Products.

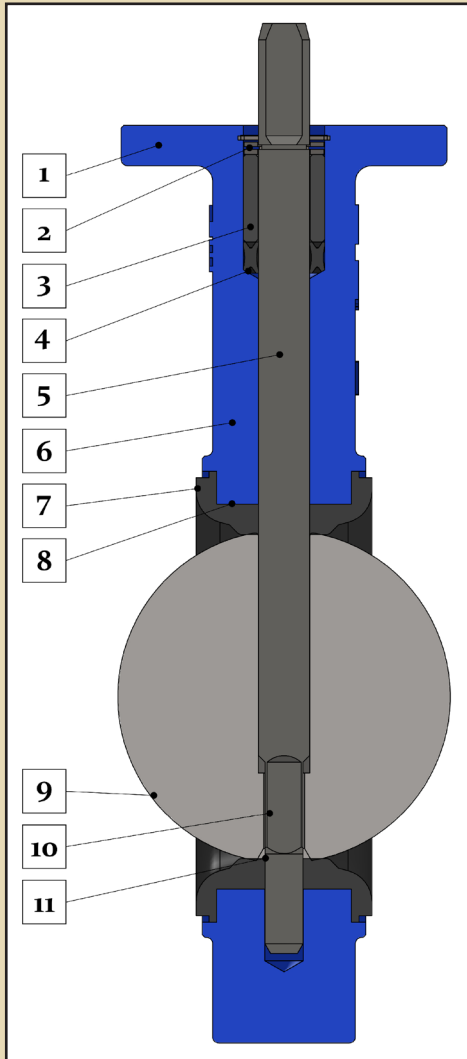

396/397 Resilient Seated Butterfly Valves

Features and Benefits:



1. All bodies are machined to tight tolerances which guarantees standard dimensions for interchangeability of parts and operators.
2. Series of snap rings and washers hold the stem, bushing and packing in and acts as a blowout proof engagement on 2" to 24".
3. Top bushing protects the stem from side thrust of operators. They are made of impact and corrosion resistant materials.
4. Special double V-shape of stem packing seal self-adjusts to protect the stem area.
5. 2" to 12" utilize one piece stems and 14" to 48" utilize two piece stems. Stems are machined to standard dimensions for interchangeability.
6. Long neck in 2" to 12" allows for insulation requirements.
7. Resil-O-Seat forms a seal against all standard ANSI 125/150 flanges eliminating separate gasket requirements.
8. The 2" to 24" seats are vulcanized in. These are rated for full dead end pressure and full vacuum. On valves 26" and larger the seat can be a phenolic backed design.
9. Disc edge is individually processed through machining and buffing for a smooth edge. This provides a bubble tight shut-off and maximizes the life of the seat.
10. The stem to disc engagement up to 36" is an internally driven design.
11. Stem and body are isolated from the line media by the interference fit of the primary seal created between the disc and seat.

396 is a wafer style body 397 is a full lug style body

STANDARD CONSTRUCTION SPECIFICATIONS:

Body:	Ductile Iron
Disc:	316 Stainless Steel, Aluminum Bronze, Nylon 11 Coated Ductile Iron, Nickel Plated Ductile Iron
Stem:	416 Stainless Steel, 316 Stainless Steel
Resilient Seat:	EPDM, Buna-N, Viton
Stem Bushing:	Teflon® – Graphite Impregnated
Stem Packing:	Buna-N

Notes:

1. Dimension "K" not applicable to 10" and larger sizes. The stem is round with a keyway.
2. Valve sizes larger than 36" are available.
3. The figures cannot be used on pipe or flange with an inside diameter less than the "E" dimension.
4. Valve sizes 2" to 12" are rated up to 200 PSI bi-directional and dead end service. Valve sizes 14" to 24" are rated up to 150 PSI bi-directional and dead end service. Valve sizes 26" and up are rated up to 150 PSI bi-directional and 75 PSI dead end service.
5. Designed in accordance with sections of API 609 Category A, ASME 16.1/16.5, ASME 16.34 and MSS SP67. Design tested in accordance with API 598.
6. Compatible with ANSI Class 125/150 flange standards.

Additional materials are available for a wide selection of applications.

Torque Chart - Figure 396/397

Valve Size	Normal Conditions					Severe Conditions				
	ΔP = 0	ΔP = 50	ΔP = 100	ΔP = 150	ΔP = 200	ΔP = 0	ΔP = 50	ΔP = 100	ΔP = 150	ΔP = 200
2"	221	230	240	250	258	373	384	400	406	418
2½"	269	283	288	302	317	454	464	475	486	507
3"	322	341	365	379	400	540	568	589	611	647
4"	480	514	542	576	602	816	848	886	918	955
5"	653	706	754	806	871	1,102	1,162	1,220	1,274	1,327
6"	907	1,008	1,109	1,210	1,285	1,529	1,642	1,756	1,868	1,965
8"	1,512	1,714	1,915	2,112	2,260	2,549	2,776	3,002	3,229	3,410
10"	2,318	2,621	2,900	3,224	3,440	3,910	4,250	4,590	4,931	5,203
12"	3,125	3,629	4,138	4,637	6,234	5,270	5,838	6,404	6,971	7,403
14"	5,160	6,120	7,080	8,040	-	7,740	8,700	9,660	10,620	-
16"	7,680	8,040	9,480	10,920	-	9,900	11,340	12,780	14,220	-
18"	8,280	10,440	12,600	14,760	-	12,432	14,580	16,020	18,900	-
20"	10,200	13,200	16,200	19,200	-	14,604	19,500	21,300	24,300	-
24"	18,000	18,513	20,400	22,200	-	23,400	24,066	26,520	30,000	-
30"	30,120	32,760	40,920	43,200	-	39,120	49,140	53,196	56,160	-
36"	46,800	48,747	57,600	81,600	-	60,840	63,600	74,880	106,080	-

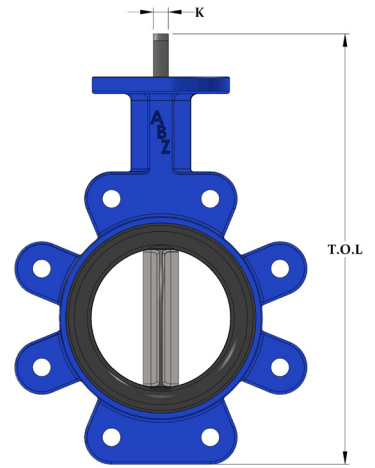

Cv is defined as the volume of water in U.S.G.P.M. that will flow through a given restriction or valve opening with a pressure drop of one (1) p.s.i. at room temperature. Recommended control angles are between 20°-75° open.

Rated Flow Coefficient (Cv) - Figure 396/397

Valve Size	Angle of Disc Opening								
	10°	20°	30°	40°	50°	60°	70°	80°	90°
2"	1.67	7.7	17	29	48	74	115	145	195
2½"	2.50	11.0	25	44	69	109	174	237	307
3"	3.33	15.7	37	64	105	165	276	377	487
4"	5.00	27.7	63	110	177	278	472	671	827
5"	8.33	43.7	99	177	276	443	752	1,083	1,325
6"	13.33	58.7	136	242	385	616	1,075	1,521	1,883
8"	20.00	107.3	247	434	687	1,094	1,821	2,671	3,239
10"	31.67	174.0	394	696	1,092	1,770	2,983	4,288	5,210
12"	47.00	251.7	578	1,002	1,665	2,654	4,398	6,466	8,026
14"	61.3	326	765	1,373	2,183	3,395	5,713	8,337	10,179
16"	81.7	426	1,000	1,783	2,816	4,494	7,556	10,981	13,322
18"	106	549	1,294	2,279	3,614	5,779	9,755	14,148	17,738
20"	124	684	1,598	2,862	4,579	7,181	12,178	17,906	22,113
24"	233	1,009	2,329	4,081	6,587	10,347	17,078	25,218	31,051
30"	364.7	1,537	3,757	6,571	10,568	16,861	27,767	39,752	50,783
36"	575	2,498	5,495	9,437	15,261	24,002	39,806	56,834	74,958

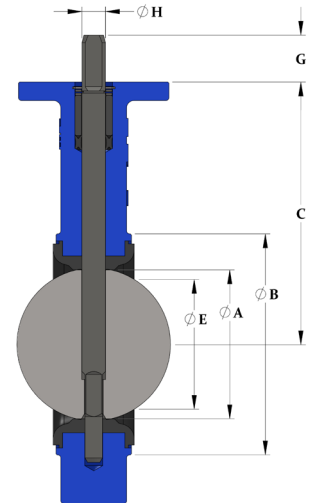

All torques shown in inch lbs. 20% Safety factor already included. Undercut disc available as special order.

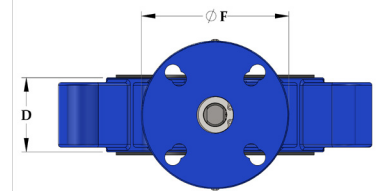

Dimensional Chart - Figure 396/397

Valve Size	Dimensions										Top Plate Drilling			Fig. 397 Tapped Lug Data			Weight (Pounds)	
	A	B	C	D	E	F	G	H	K	T.O.L.	Bolt Circle	No. Holes	Hole Dia.	Bolt Circle	No. Holes	Tap	396	397
2"	2	3½	5½	1⅝	1⅜	4	1¼	⅞	⅜	9.25	3¼ / F07	4	⅞	4¾	4	5/8-11 UNC	7	8
2½"	2½	4	6	1¾	2⅛	4	1¼	⅞	⅜	10.00	3¼ / F07	4	⅞	5½	4	5/8-11 UNC	8	9
3"	3⅝	4¾	6¼	1¾	2⅞	4	1¼	⅞	⅜	10.45	3¼ / F07	4	⅞	6	4	5/8-11 UNC	9	10
4"	4⅞	5⅛	7	2	3⅝	4	1¼	⅞	⅞	12.50	3¼ / F07	4	⅞	7½	8	5/8-11 UNC	13	20
5"	4⅛	7⅞	7½	2⅞	4¾	4	1¼	⅞	½	13.50	3¼ / F07	4	⅞	8½	8	3/4-10 UNC	19	23
6"	6	8⅞	8	2⅞	5½	4	1¼	⅞	½	14.42	3¼ / F07	4	⅞	9½	8	3/4-10 UNC	20	27
8"	7⅛	10¼	9½	2½	7½	6	1¼	⅞	⅝	17.20	5/F12	4	⅞	11¾	8	3/4-10 UNC	36	43
10"	9¼	12⅞	10¾	2½	9⅞	6	2	1⅞	¼ x ¼	20.44	5/F12	4	⅞	14¼	12	7/8-9 UNC	49	63
12"	11½	14⅞	12¼	3	11⅞	6	2	1⅞	¼ x ¼	23.26	5/F12	4	⅞	17	12	7-8-9 UNC	70	90
14"	13⅞	17	12	3	13⅞	6	2¼	1⅞	⅝ x ⅝	25.25	5	4	⅞	18¾	12	1-8 UNC	95	115
16"	15⅞	19⅞	12⅛	4	15	6	2¼	1⅞	⅞ x ⅞	27.45	5	4	⅞	21¼	16	1-8 UNC	144	187
18"	17⅞	21⅞	14½	4⅞	16⅞	8	3	1⅞	½ x ½	30.83	6½	4	⅞	22¾	16	1 1/8-7 UNC	180	216
20"	19⅞	23⅞	15⅞	5	18¾	8	3	2⅞	½ x ½	33.75	6½	4	⅞	25	20	1 1/8-7 UNC	277	334
24"	24⅞	28½	22¼	6	22⅞	8	3	2⅞	1/2 x 1/2	41.96	6½	4	⅞	29½	20	1 1/4-7 UNC	417	519
30"	29⅞	38¾	26	6⅞	28⅞	11⅛	3¾	63.35mm	*18x8 mm	51.73	10	8	18mm	36	28	1 1/4-7 UNC	660	930
36"	34	46	28⅞	8	33⅞	11⅛	5⅞	75mm	*20x9 mm	59.29	10	8	18mm	42¾	32	1 1/2-6 UNC	1570	1770

*Valve has two keyways.

Our goal is to become the leading provider of valves, valve related products and services in terms of customer satisfaction, safety and financial performance.

Our experienced management team and employees are dedicated to solving our customers' problems. We invest in long term relationships and cooperate on product development with our clients, we consider them our partners.

OUR CORE VALUES

No one gets hurt: The safety of our employees and customers is our first priority coupled with a healthy respect for the environment.

Integrity: In everything we do, in every interaction, both internally and externally, we strive to operate with the upmost integrity and mutual respect.

Customer focused: Our products enhance our customer's performance and we listen to their needs and work with them to solve their challenges.

Good place to work: We are committed to creating a workplace that fosters innovation, teamwork and pride. Every team member is integral to our success and is treated equally and fairly.



ABZ Valve & Controls
113 W. Main
Madison, KS 66860
620.437.2440 620.437.2435 [f]
f-e-t.com/ABZ
ABZ1008.03.17

Forum Arabia Limited
3544, 15th Street
Dammam 2nd Industrial City, 34325
Kingdom of Saudi Arabia
Forumarabiasales@f-e-t.com