

NOTES FOR THE 3D PRINTED SKEETER PARTS

General Note: Printing the parts in ABS will result in a 20 percent weight reduction over PLA.

PROP

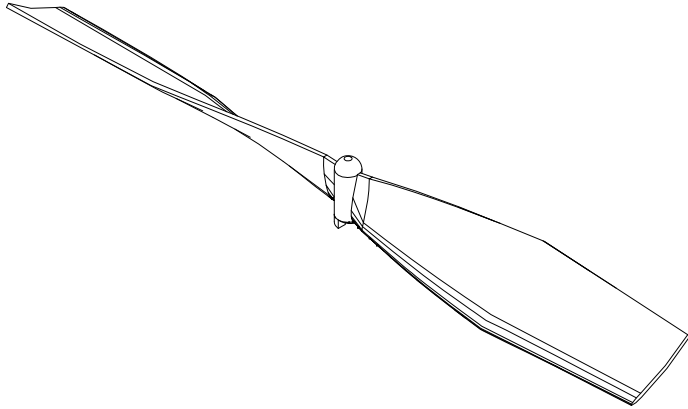

It is suggested that the prop be printed with the forward face down. Use slicer generated supports. Also use the minimum layer height allowed for your printer.

PROP HANGER

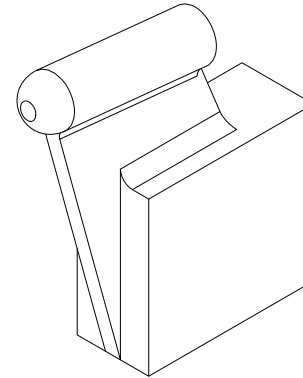

It is suggested that the prop hanger be printed in the orientation shown. Supports are not required. Also use the minimum layer height allowed for your printer.

WING CLIPS

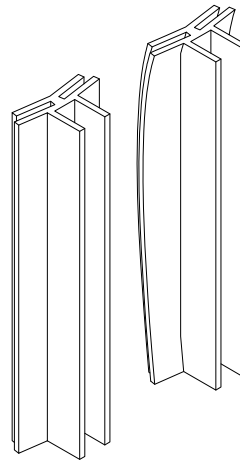

The wing clips can be printed without using supports if printed in the orientation shown. A layer resolution of ,2 mm works well.