

EGD MFG INC  
2320 Kishwaukee Street  
Rockford IL 61104

Parts List and Maintenance Instructions  
1.5 Inch Bore Adjustable and Fixed Orifice  
EGD MFG INC Shock Absorbers

www.egdmfg.com  
sales\_desk@egdmfg.com

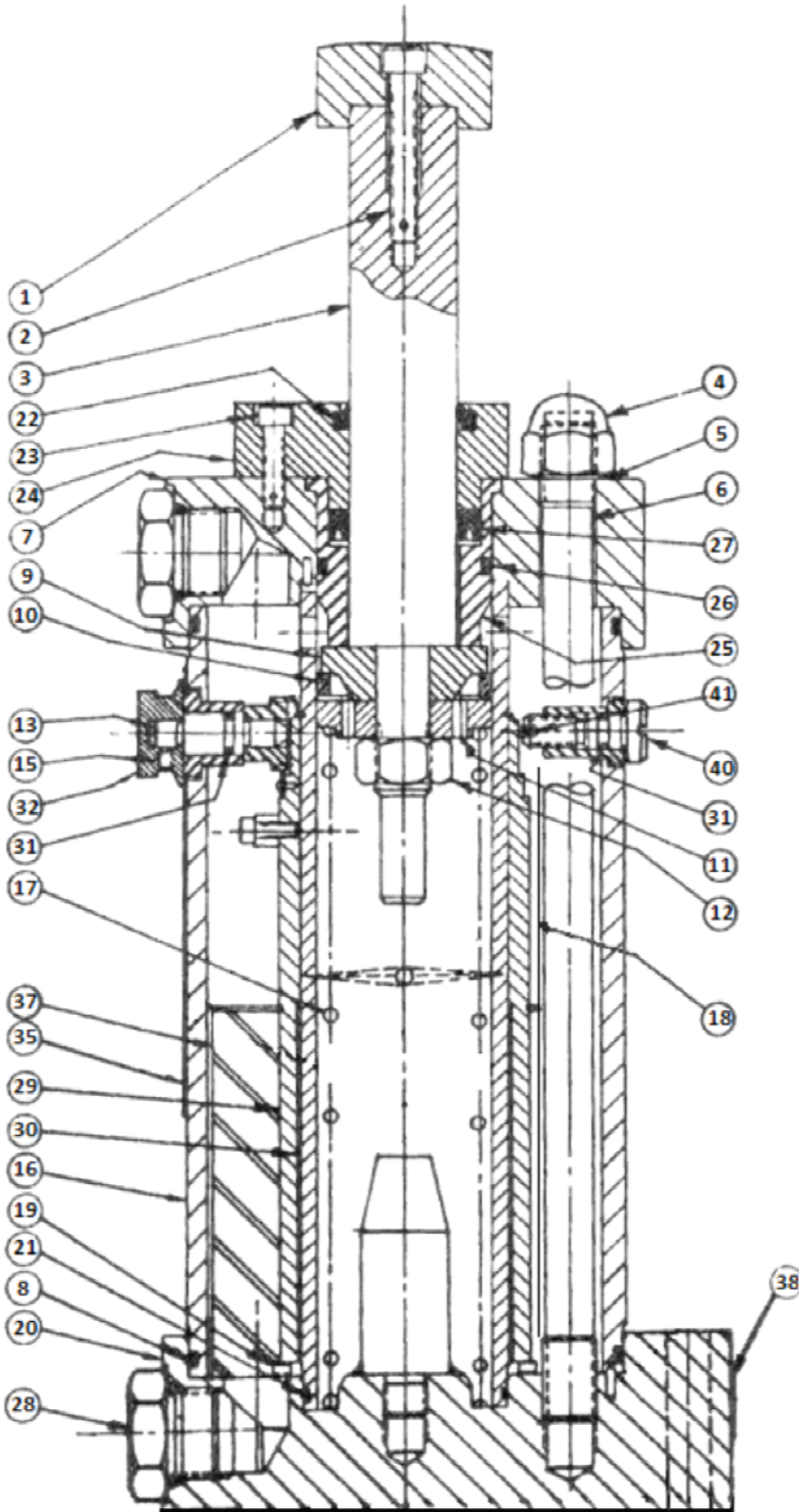

Item	Part Name	Req.
1	BUMPER	1
2	BUMPER SCREW	1
3	PISTON ROD	1
4	ACORN NUT	4
5	COPPER WASHER	4
6	TIE ROD	4
7	FRONT HEAD	1
8	O'RING	2
9	FOLLOWER	1
10	PISTON RING	1
11	PISTON	1
12	PISTON ROD NUT	1
13	DRIVE GEAR ASSEMBLY*	1
15	SET SCREW*	1
16	RESERVOIR TUBE	1
17	RETURN SPRING	1
18	BAFFLE TUBE*	1
19	WAVE SPRING	1
20	BACK HEAD	1
21	O'RING	1
22	ROD SCRAPER	1
23	RETAINER SCREW	4
24	PACKING RETAINER	1
25	GLAND	1
26	GLAND O'RING	1
27	ROD PACKING	1
28	PORT PLUG	2
29	OUTER METERING TUBE*	1
30	INNER METERING TUBE	1
31	O'RING	2
32	KNOB*	1
35	LABEL DIAL*	1
37	CELLULAR ACCUMULATOR	3
38	WARNING PLATE	1
40	LOCK SCREW*	1
41	PELLET (LOCK PIN)*	1

\*Not required on fixed orifice units.

EGD MFG INC  
2320 Kishwaukee Street  
Rockford IL 61104

Parts List and Maintenance Instructions  
1.5 Inch Bore Adjustable and Fixed Orifice  
EGD MFG INC Shock Absorbers

www.egdmfg.com  
sales\_desk@egdmfg.com

## MOUNTING

Mount the Shock Absorber securely making certain that the shock load will strike the piston rod bumper squarely at all positions throughout its full stroke. At least one of the port plugs must be uppermost to permit bleeding air from the unit.

Attach the make-up reservoir, if used, preferably in the uppermost part of the Shock Absorber to permit air bleeding and replacement of lost fluid.

## INSPECTION AND TESTING

Periodically inspect the E.G.D. Adjustable Shock Absorber system to make sure that:

- A. It is completely filled with fluid and has no air trapped inside (see filling instructions.)
- B. The piston rod fully returns to the "ready" position after each stroke.
- C. The piston rod moves and can rotate freely throughout its entire stroke.
- D. All mounting bolts are tight.

## OPERATION

The Shock Absorber does work in bringing a load to stop. It converts this work into heat and dissipates this heat into the surroundings. A spring returns the piston rod to its starting position, ready for the next working stroke. It is extremely important that that piston rod return promptly, otherwise the Shock Absorber cannot do its job.

Field repair of this unit should generally be limited to the ram assembly, gland, retainer, rod packing, wiper, spring and "O" rings. If repairs other than the above are necessary, it is recommended that the entire unit be returned to the factory. Contact local distributor for information.

## DISASSEMBLY

1. Remove the four retainer screws (23).
2. Pull out ram assembly with gland (25) and gland retainer (24).
3. Remove spring (17) and pour out fluid.
4. Remove bumper screw (2) and cap (1).

5. Next remove gland retainer (24) and gland (25) so that rod packing (27), rod wiper (22) and gland "O" ring (26) can be replaced.

6. If piston ring (10) must be replaced, the follower (9) and piston (11) may also have to be replaced. Order piston ring kit (ring, piston and follower).

## ASSEMBLY

1. Clean all parts in a good commercial solvent before starting assembly.

2. Inspect all parts to make sure they are in good condition. Replace rod packing (27), rod wiper (22) and gland "O" ring (26) for all repairs.

3. If piston ring is replaced then piston and follower may also have to be replaced.

4. Lubricate all "O" rings with fluid to be used before assembly.

5. Assemble Ram. Place follower (9) on first with contour section away from shoulder. Next add piston ring (10) then piston (11) with flat section toward piston ring. Screw on rod nut (12) and torque to 50 Ft-Lb.

6. Assemble Gland. Place "O" ring (26) in its groove and insert packing (27) into its cavity with lip down.

7. Place gland (25) on rod with solid part of gland facing piston.

8. Next insert rod wiper (22) into retainer (24) and place on rod with wiper facing out.

9. Assemble bumper cap (1) to rod with bumper screw (2) and torque to 20 Ft-Lbs.

10. Place spring into unit and fill with fluid specified.

Wait a few seconds for oil to displace air, you will see air bubbles coming through the oil. Jiggle the spring and add more oil. The oil level should be to the bottom of the return holes in the metering tube (30).

11. Insert ram assembly into the metering tube, set the gland in place, push retainer holes down against the front head (17), insert retainer screws (23) and torque to 10 Ft-Lbs. Caution do not over torque these screws.

12. Place unit on its side with the port at top. Remove port plug (28) and observe if unit is full. Excess oil will bleed out or if more fluid is needed, you can add to the unit through this port. All air must be out of unit and it must be full of fluid Texaco Regal (R & O) 150 or equivalent.

13. Replace port plug (28) and tighten.