

Center Windshield Pattern

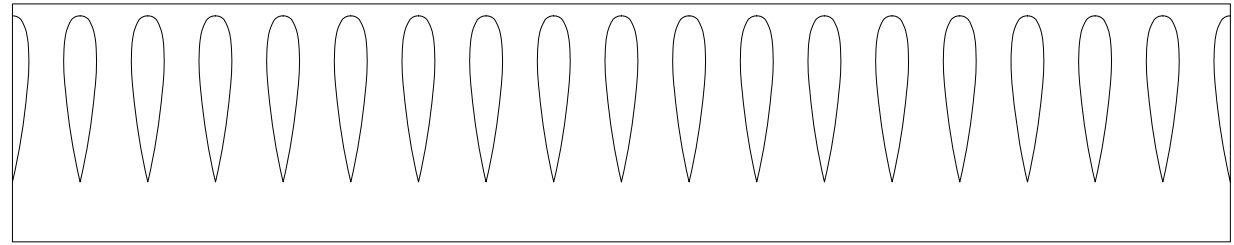

Cowl pattern

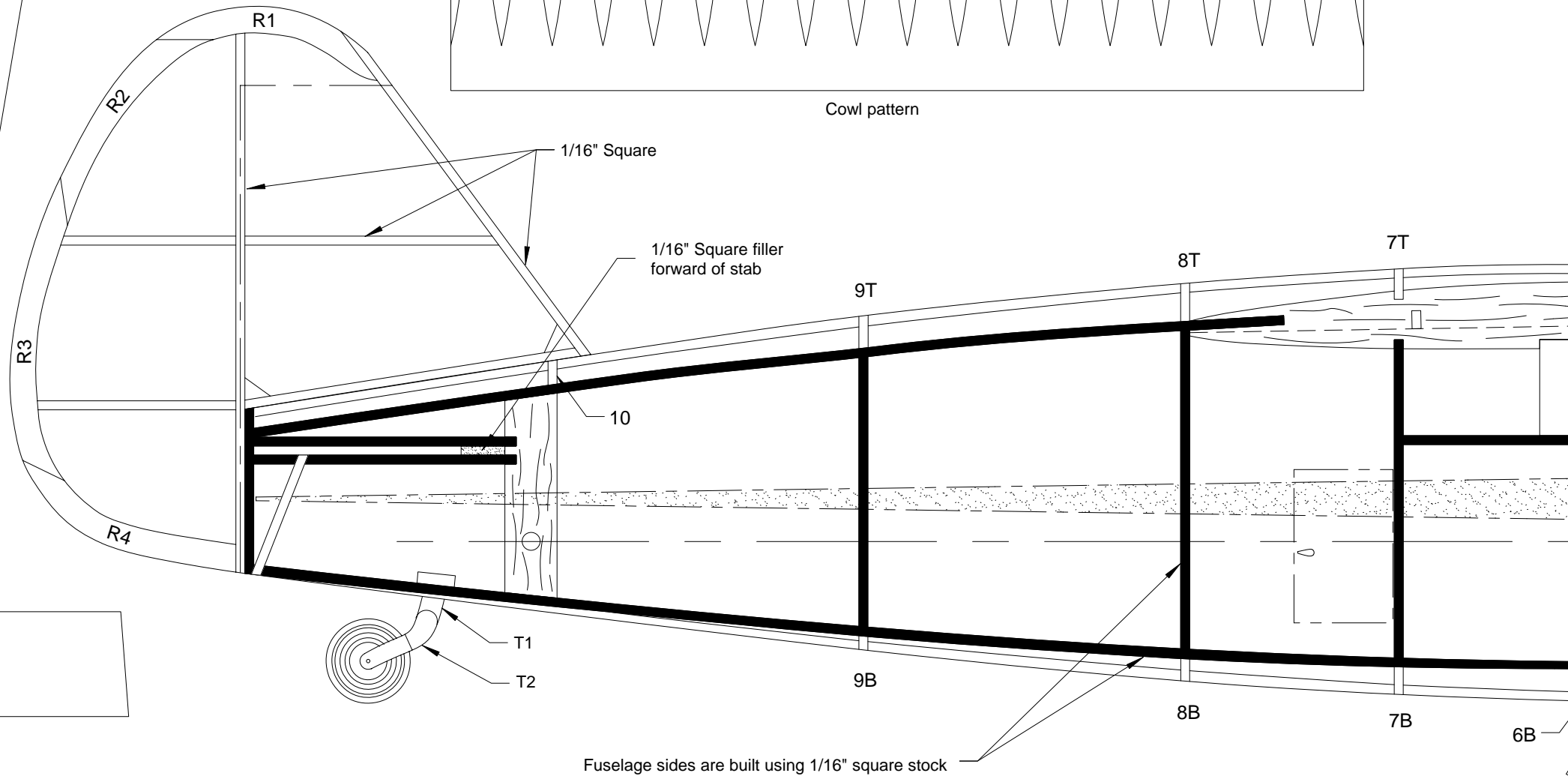

Side Windows Pattern

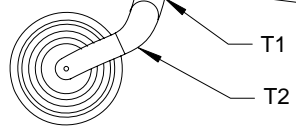

Fuselage sides are built using 1/16" square stock

Entry step is made from rounded 1/16" square stock build over the plan. One goes on each side

Comet Stinson Reliant

Wingspan - 25"

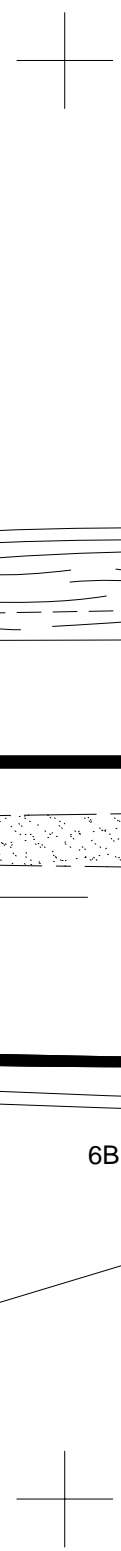
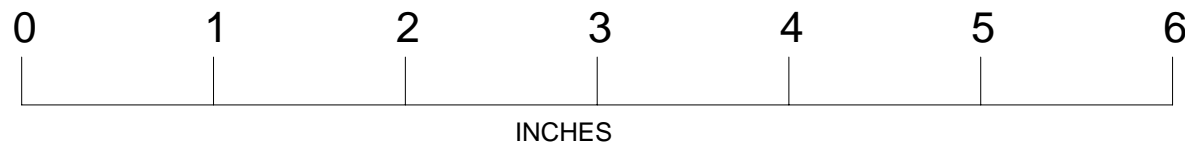

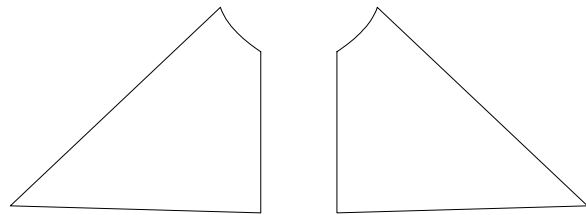

Side Windshield Pattern

Wing struts are 1/16" x 1/8" strip stock sanded to a streamline cross section

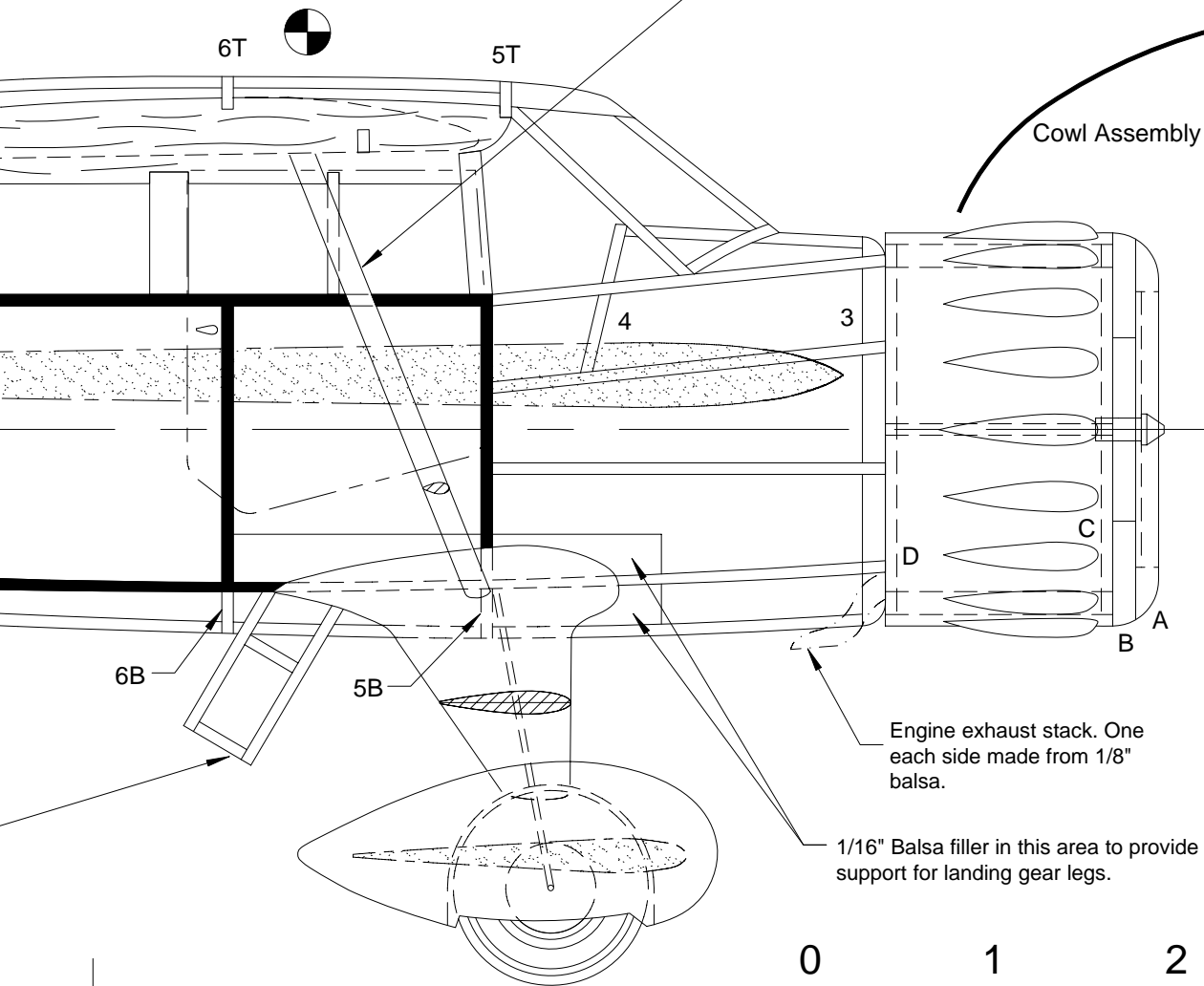

1/16"X1/8" Balsa strip stock

Cowl Assembly

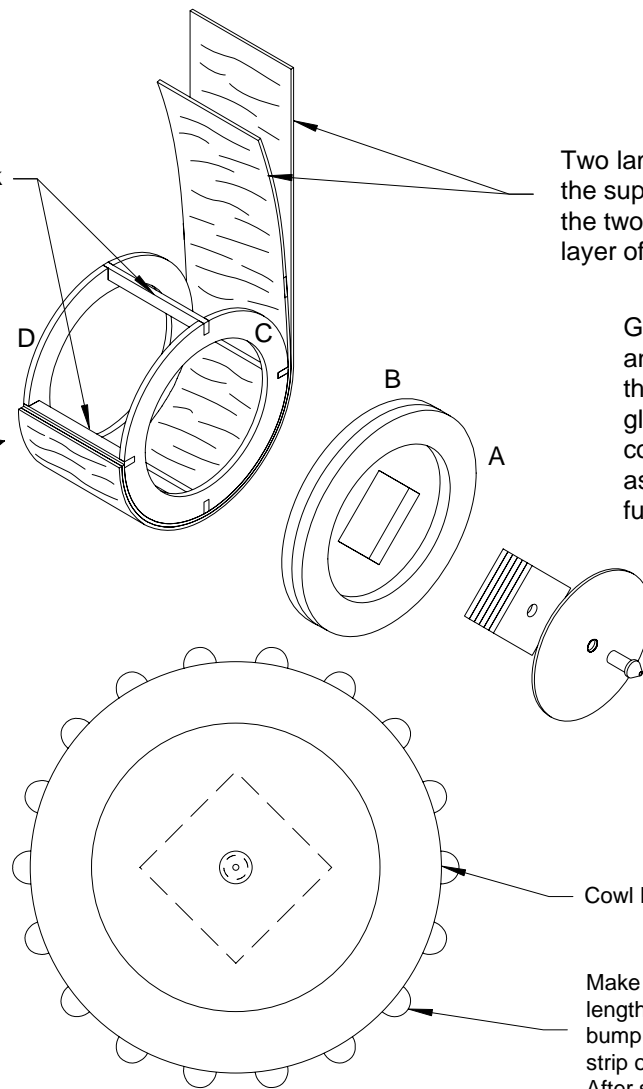

Two laminations of 1/32" balsa. Use the supplied template when cutting the two laminations. Apply a thin layer of glue between laminations.

Glue cowl rings A and B together and then to the cowl structure after the balsa laminations have been glued in place. Sand the nose of the cowl to a radius. The entire assembly is glued to the front of fuselage former 3.

Nose plug is a 1/32" plywood disk with a locating key made from a lamination of 1/16" balsa pieces. A Peck thrust bearing is shown.

Cowl bump template seam goes here.

Make cowl bumps by cutting a piece of 3/16" balsa 5" long by the length of the cowl bump wide. Sand this strip to shape of the cowl bump as viewed from the top. Sand one end of the now streamlined strip of balsa to the shape of the cowl bump as viewed from the side. After sanding, cut off the sanded end at the depth of the cowl bump. Repeat this process until you have 18 cowl bumps fabricated. The template provided on the plan can be used to locate each cowl bump. Place the template so the seam is at the quarter point on the side of the cowl.

Engine exhaust stack. One each side made from 1/8" balsa.

1/16" Balsa filler in this area to provide support for landing gear legs.

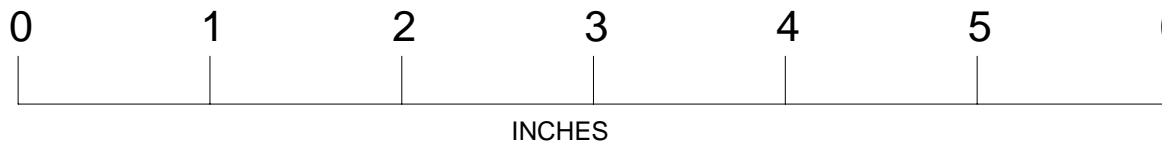

Comet Stinson Reliant

Wingspan - 25"

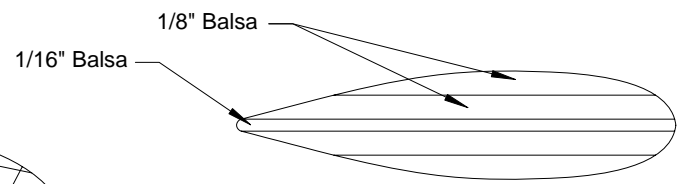
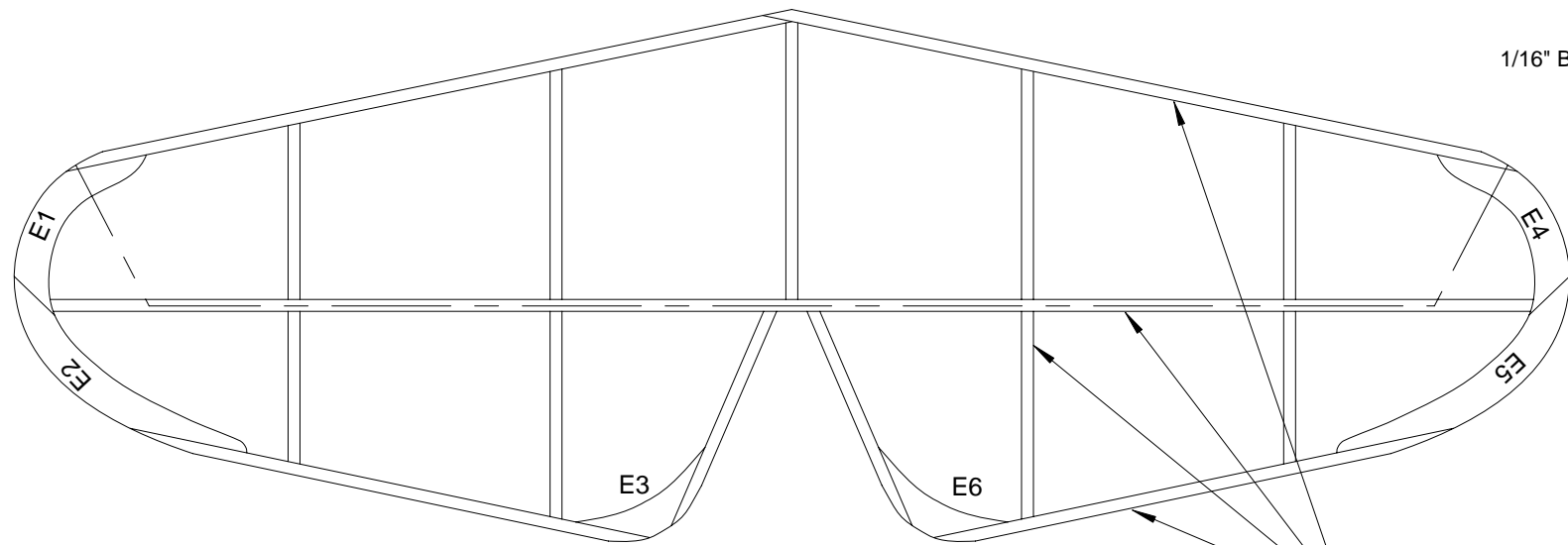
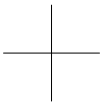

Wheel pant top view

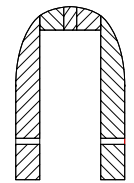

Wheel pant cross section

1/16" Square

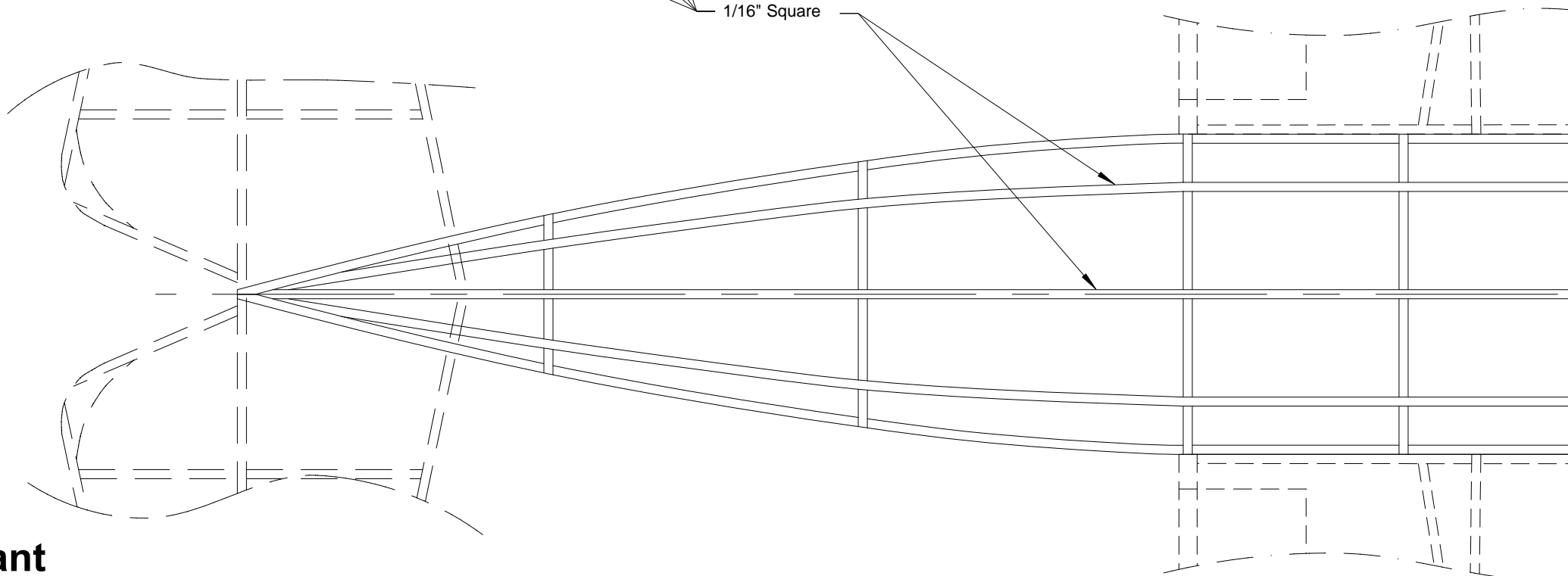

Comet Stinson Reliant

Wingspan - 25"



INCHES

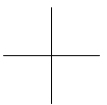

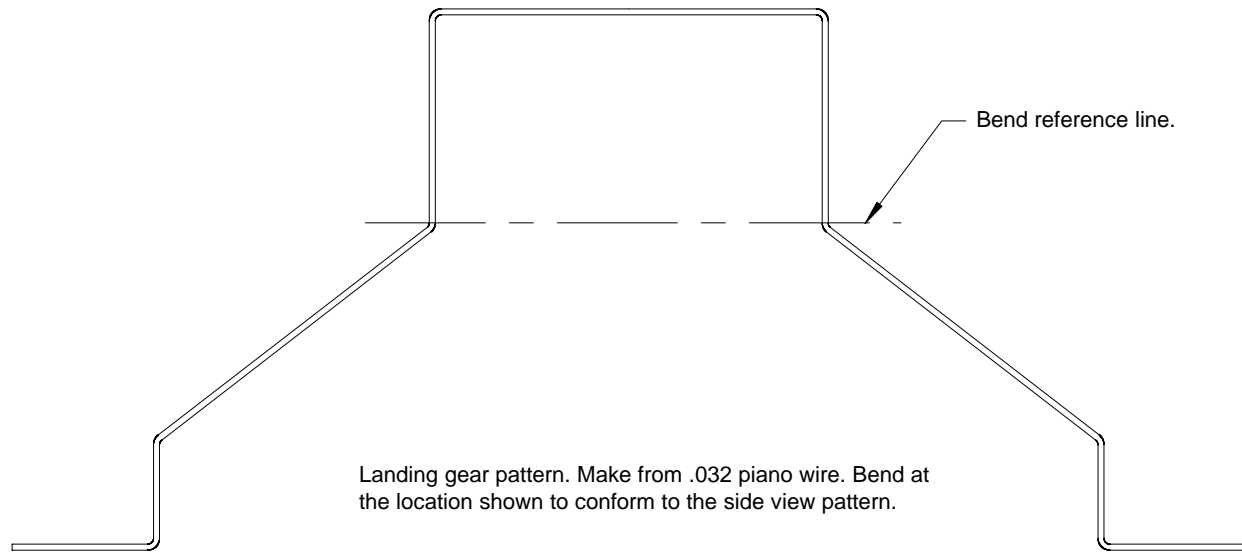

Landing gear pattern. Make from .032 piano wire. Bend at the location shown to conform to the side view pattern.

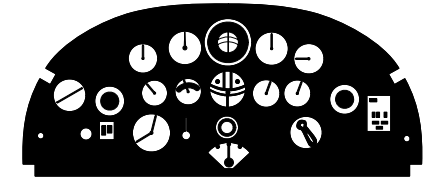

Glue to former 4

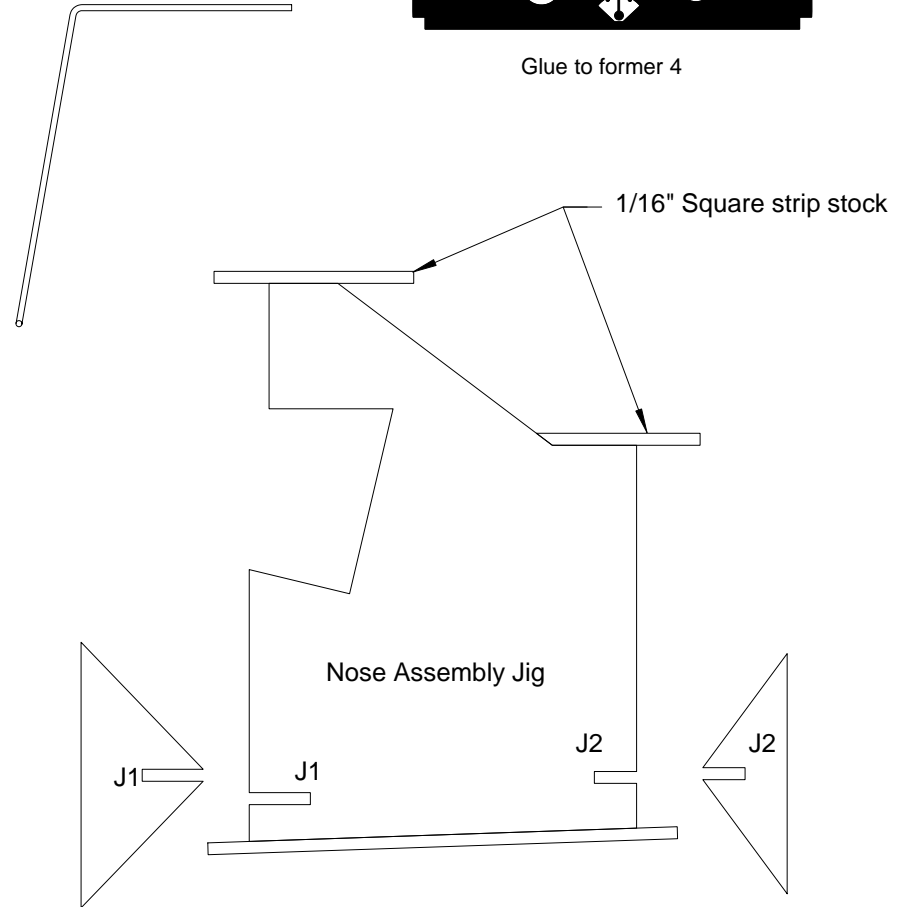

See fuselage assembly page for information on using the nose assembly jig.

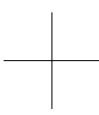
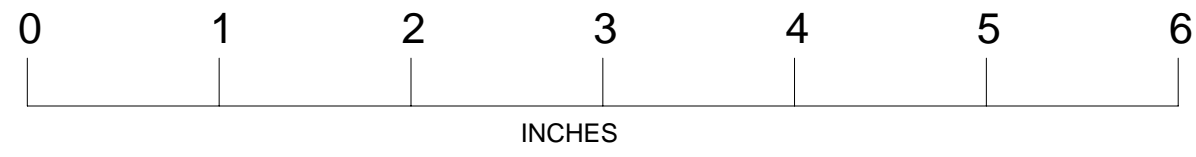
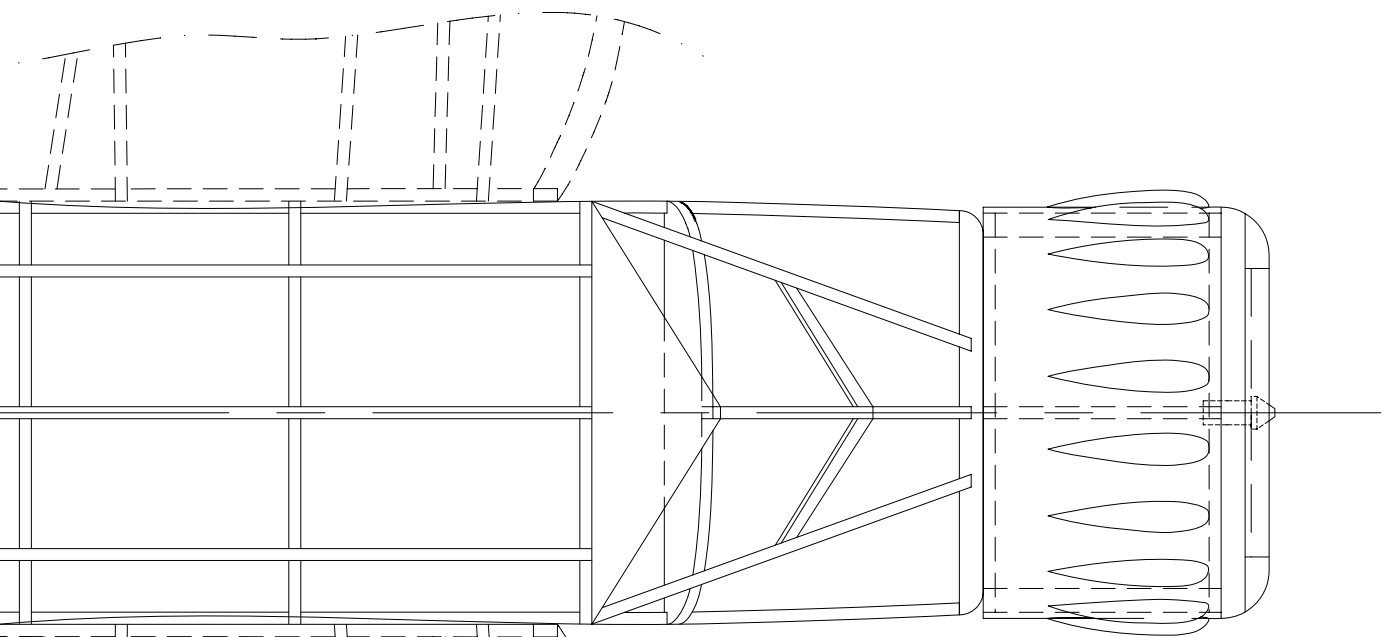

Comet Stinson Reliant

Wingspan - 25"

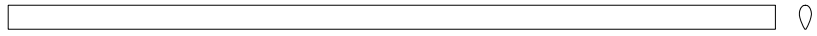

Wing strut - make from 1/16"x1/8" strip stock. Sand to streamline cross section and trim to fit.

Wing strut mount pad

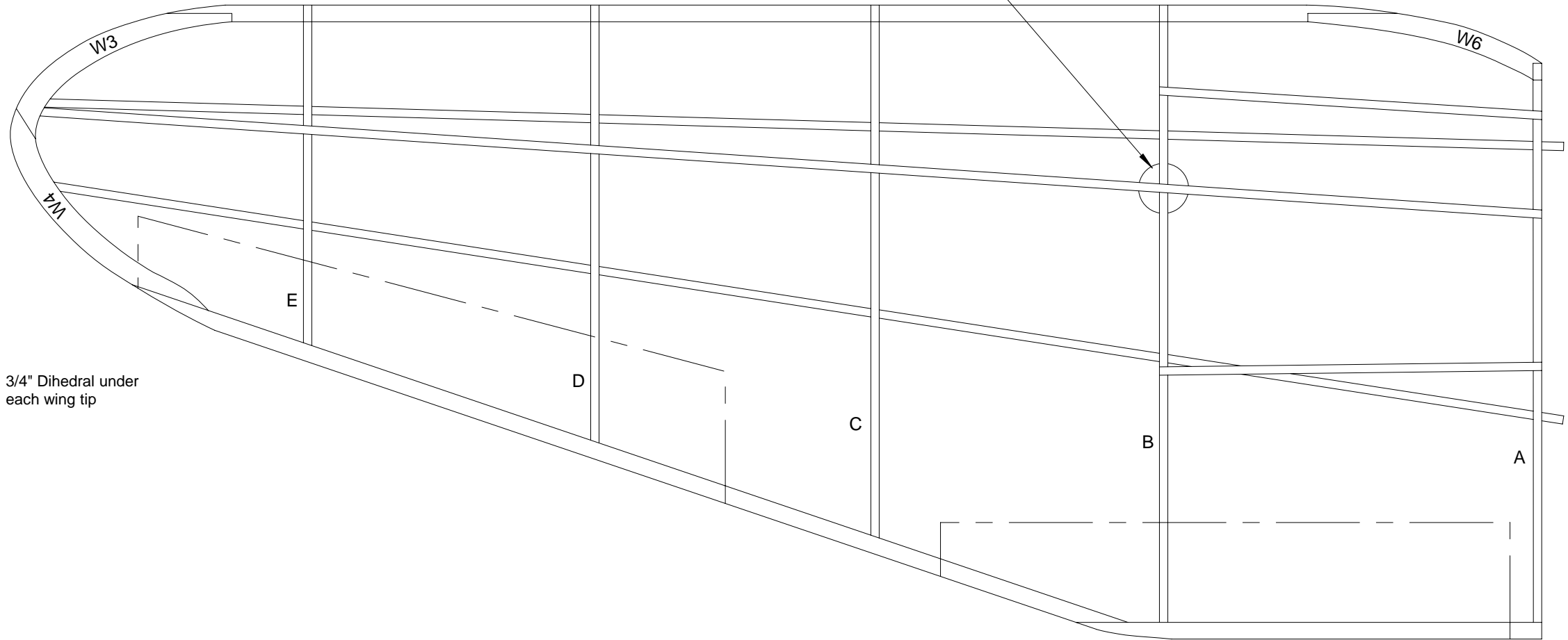

3/4" Dihedral under each wing tip

Comet Stinson Reliant

Wingspan - 25"

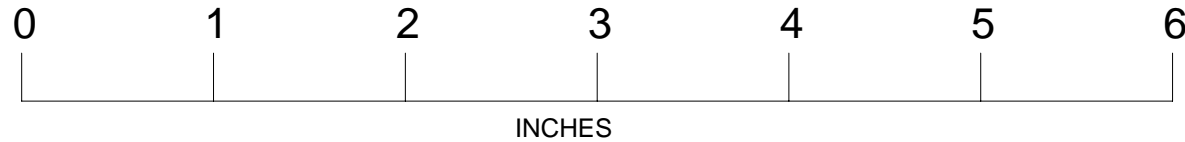

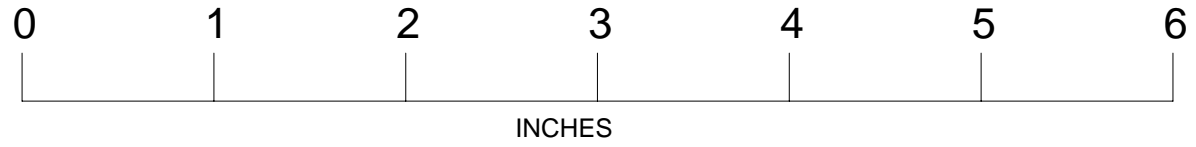
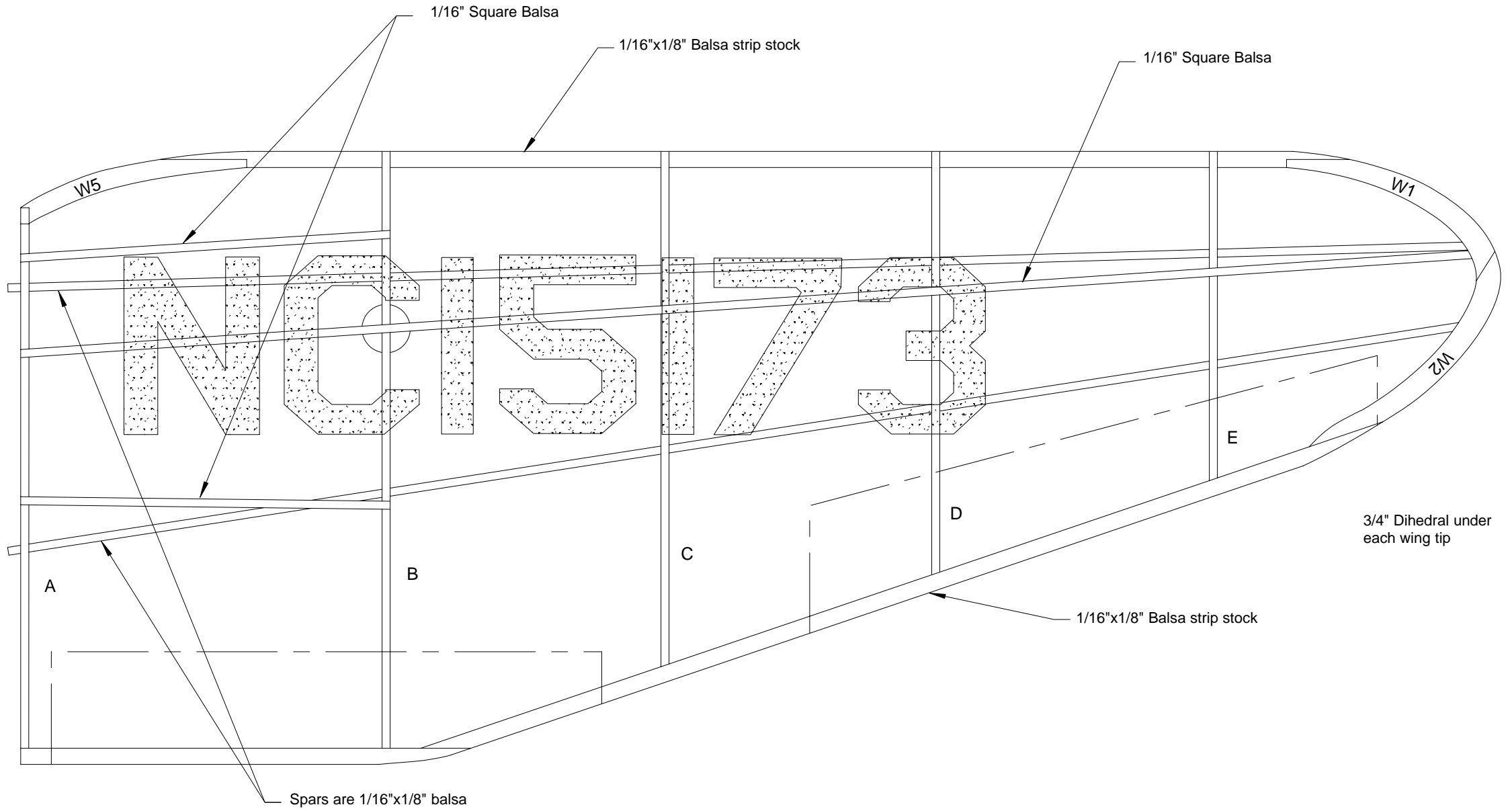

Comet Stinson Reliant

Wingspan - 25"

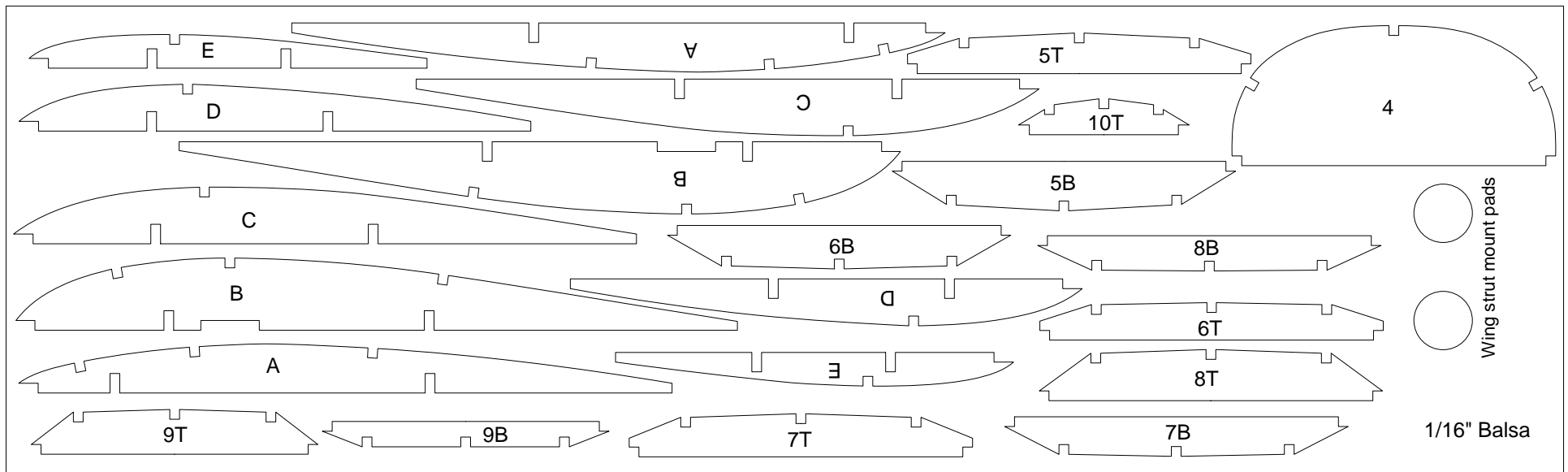
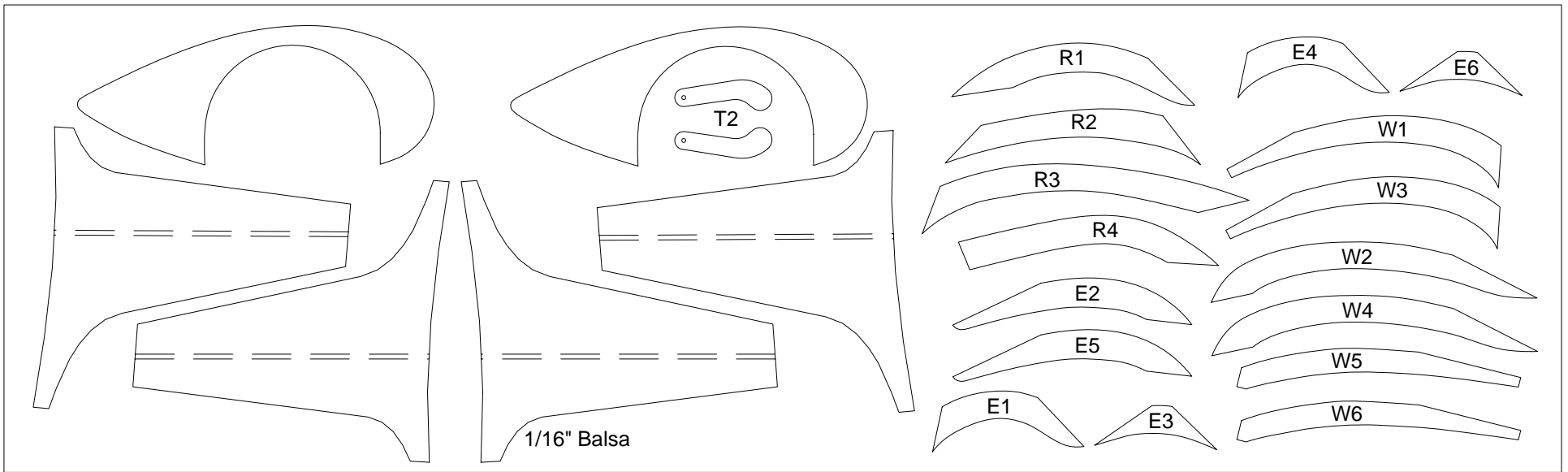

Comet Stinson Reliant

Wingspan - 25"

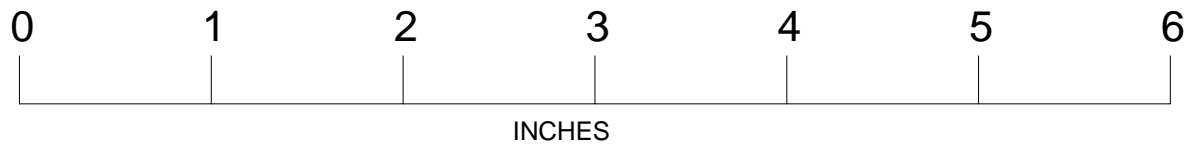

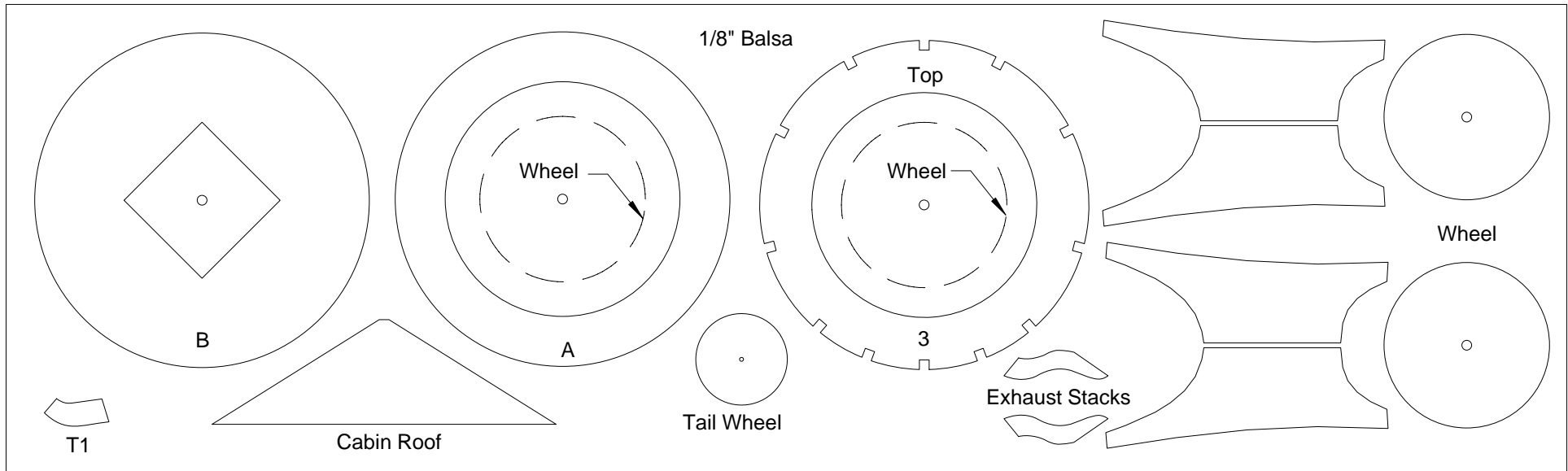
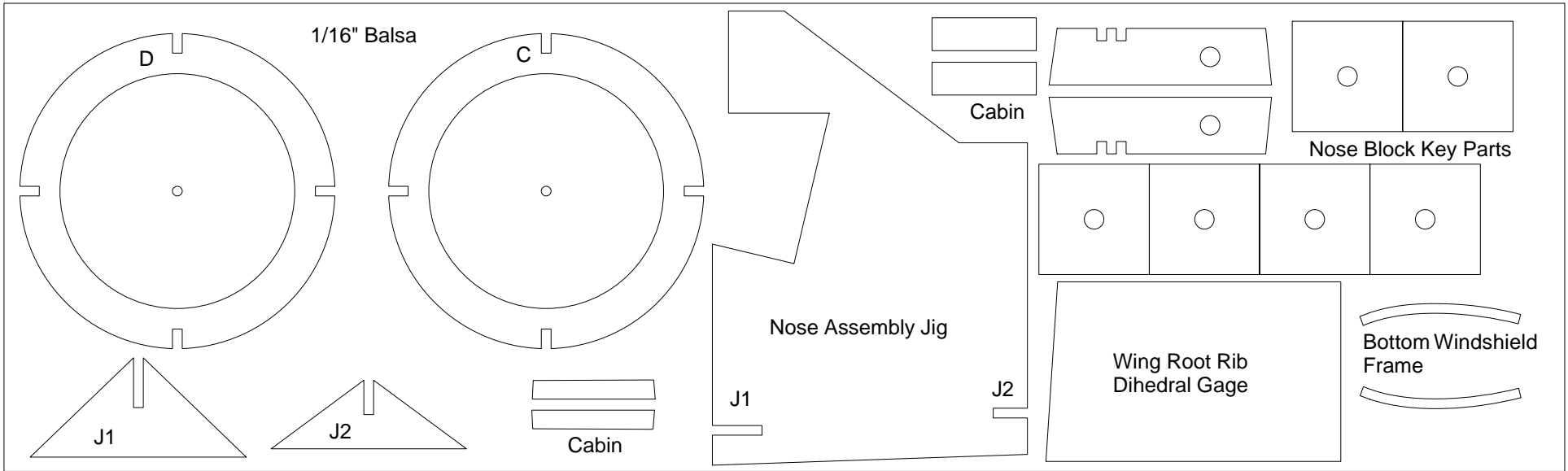

Comet Stinson Reliant

Wingspan - 25"



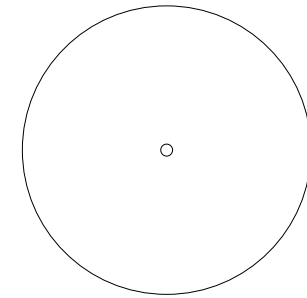
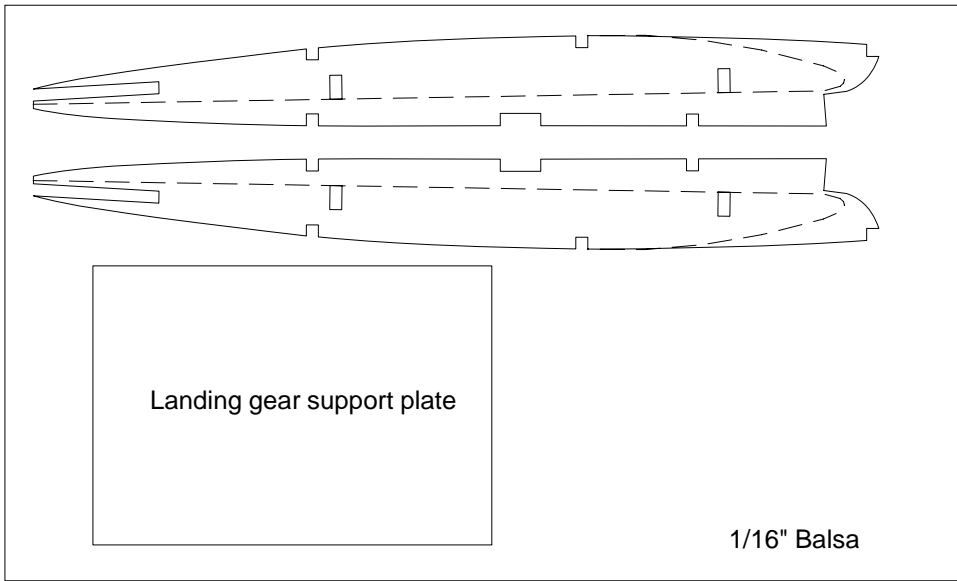
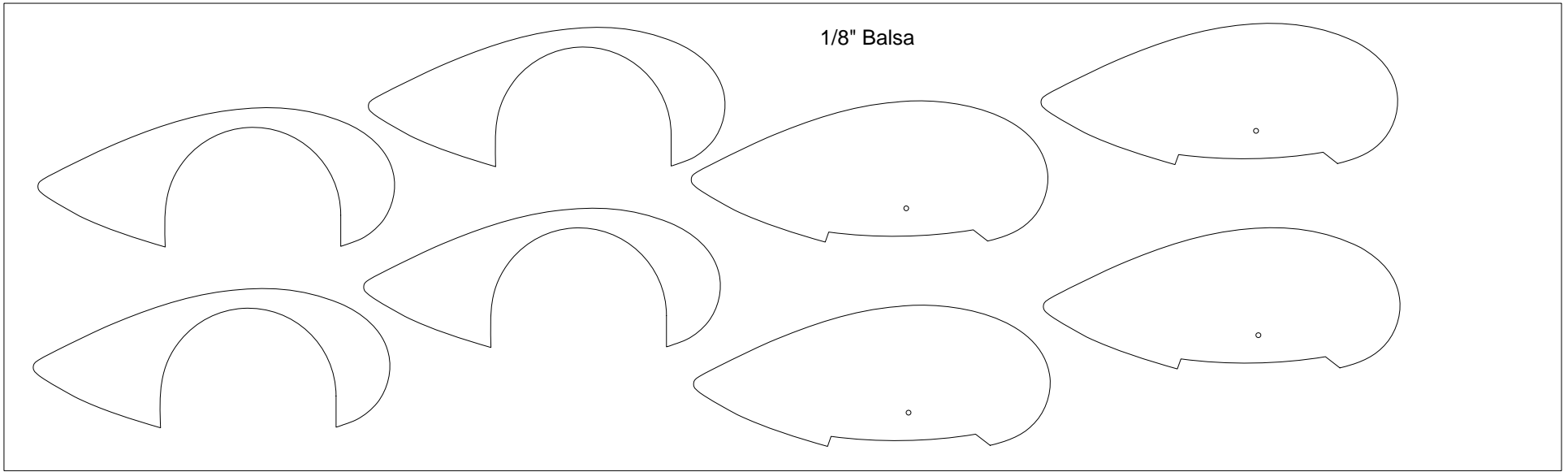

Comet Stinson Reliant

Wingspan - 25"

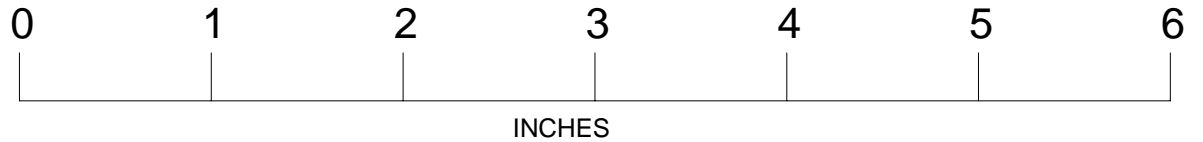

FUSELAGE ASSEMBLY STEPS

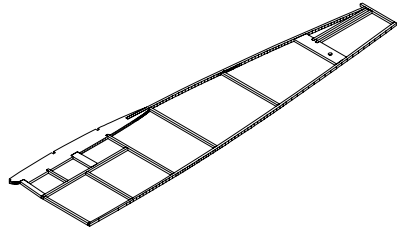

Step 1. Assemble each side over the plan. Do not include the structure forward of the cabin.

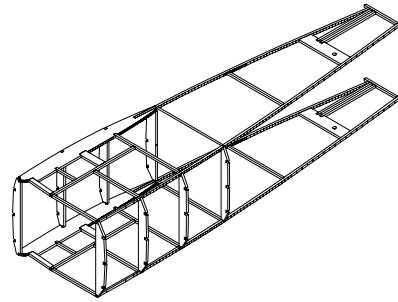

Step 2. Using formers 5 through 8 assemble the sides as shown. Make sure everything is square.

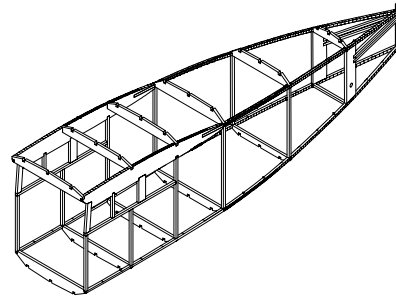

Step 3. Sand the rear of the fuselage sides on the inside face to a taper so when joined the thickness will be 1/16". Glue the fuselage sides together at the rear and then add formers 9 and 10.

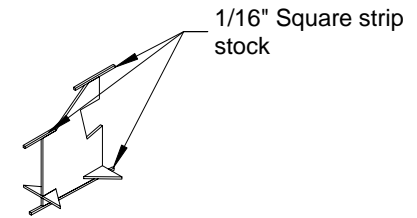

Step 4. Assemble the jig that is used in the assembly of the fuselage nose. Use 1/16" square strip stock for keys on the jig as shown.

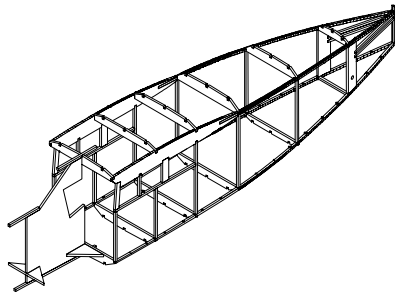

Step 5. Attach the jig to the fuselage as shown. The keys fit in the center notches of formers 5T and 5B. Use pins to hold the jig in place.

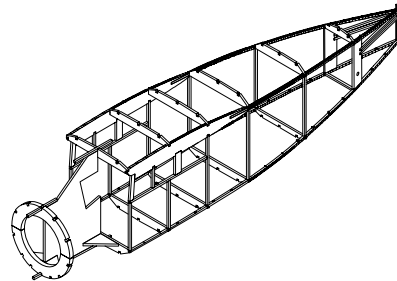

Step 6. Place former 3 on the jig using the keys in the top and bottom notches as alignment guides. Hold the former to the jig with a pin.

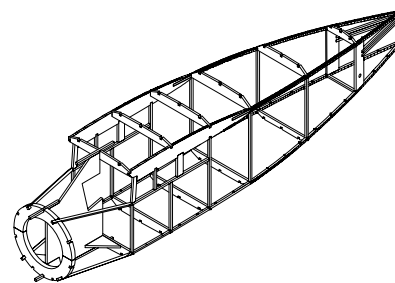

Step 7. Add the pieces of 1/16" strip stock shown. These pieces will set former 3 in place.

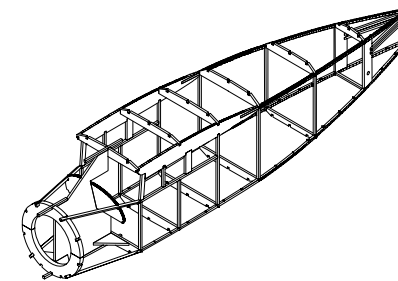

Step 8. Place former 4 on the jig and in contact with the top two longerons that had been installed. The jig sets the former at the proper angle. It will be necessary to adjust the two former notches to get a good fit.

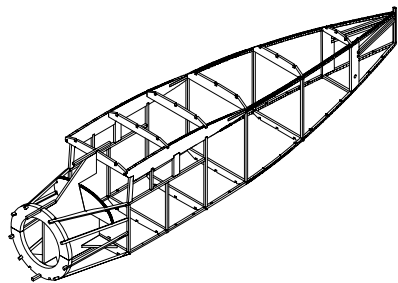

Step 9. Add the remaining side stringers to the nose.

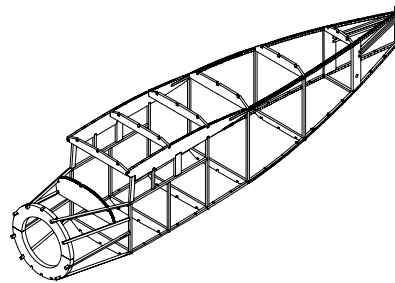

Step 10. Remove the jig. Removing the keys from the top of the jig will allow the jig to be extracted from the bottom of the fuselage.

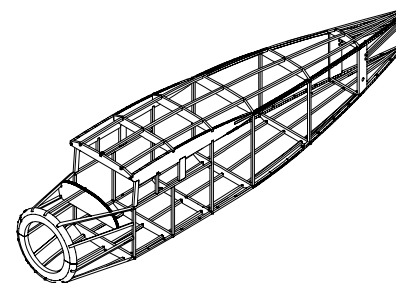

Step 11. Add the top and bottom stringers. Trim the stringers at the nose flush with former 3. Sand the edge of former 3 to a radius.

Comet Stinson Reliant

Wingspan - 25"

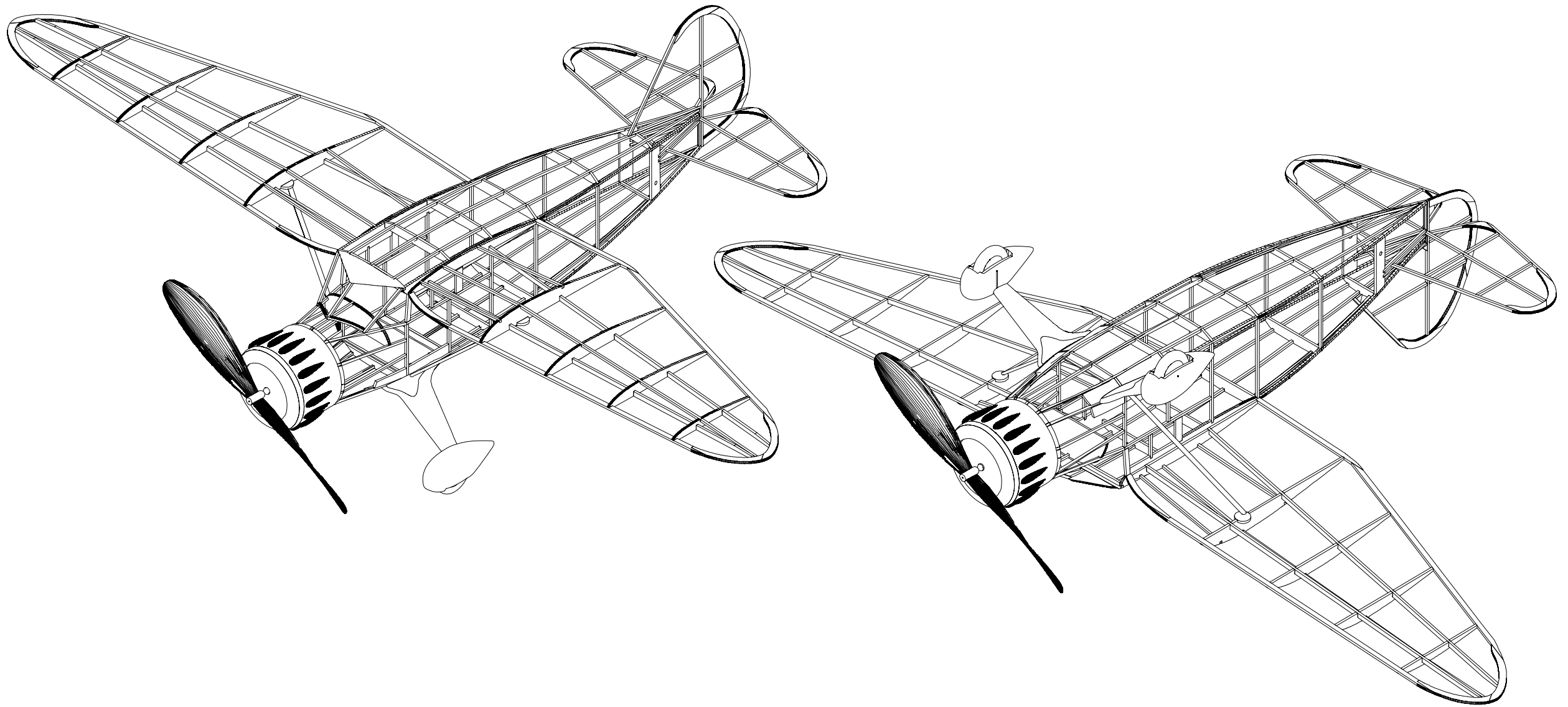

Comet Stinson Reliant

Wingspan - 25"