

Thermal Flow Switch for Water-Based Liquids



measuring
•
monitoring
•
analyzing

KAL



- Optimal Temperature Compensation
- Simultaneous Monitoring of Flow and Temperature
- Remote Probe Allows Installation with Minimal Clearance
- Can be Used with Extremely Low Velocities
- No Moving Parts
- Low Pressure Loss
- Easy to Operate
- Insensitive to Dirt



KOBOLD companies worldwide:

ARGENTINA, AUSTRALIA, AUSTRIA, BELGIUM, BULGARIA, CANADA, CHILE, CHINA, COLOMBIA, CZECH REPUBLIC, EGYPT, FRANCE, GERMANY, HUNGARY, INDIA, INDONESIA, ITALY, MALAYSIA, MEXICO, NETHERLANDS, PERU, POLAND, REPUBLIC OF KOREA, ROMANIA, SINGAPORE, SPAIN, SWITZERLAND, TAIWAN, THAILAND, TUNISIA, TURKEY, UNITED KINGDOM, USA, VIETNAM

KOBOLD Instruments, Inc.
1801 Parkway View Drive
Pittsburgh, PA 15205
Main Office:
1.800.998.1020
1.412.788.4890
info@koboldusa.com
www.koboldusa.com



Description

The KAL electronic flow switch continuously monitors the flow of liquid media. It can be used wherever flows must be monitored with a minimal loss of pressure. The one-piece, stainless steel sensor has no moving parts, making the KAL very reliable. Strength is another advantage inherent in this design, allowing use at high pressures and virtually eliminating any chance of mechanical damage.

Operation

The KAL design is based on the time proven calorimetric principle. The sensor is internally heated to a few degrees above the temperature of the media. Flow of the media causes removal of heat from the sensor, resulting in a cooling effect. The degree of cooling is a measure of the flow velocity.

The KAL electronics allow the user to interface with the sensor to provide access to flow or temperature control. The system can act as either a flow switch only, or a combined flow and temperature switch. Switching is achieved by means of internal SPDT relays.

Full temperature compensation of the switch point is readily obtained through a simple, one-time, calibration procedure. This assures elimination of set-point drift caused by temperature variations in the process liquid.

Temperature Compensation

The KAL flow switch uses a microprocessor to compensate for temperature changes through use of an internal table. End-users can easily adapt the equipment to their unique installations. Compared to conventional calorimetric flow switches, the technically advanced design of the KAL provides a switch point which changes negligibly with temperature.



Approximate Switching Range at Various Pipe Diameters

Nominal ID (inch)	Range Water (GPM)	Nominal ID (inch)	Range Water (GPM)
1/4	0.02...1.0	2 1/2	2.0...100
5/16	0.04...1.5	3	3.0...140
3/8	0.05...2.2	4	6.0...250
1/2	0.08...4.0	6	12.0...575
3/4	0.2...9.0	8	20...1025
1	0.4...16	10	35...1600
1 1/4	0.5...25	12	50...2300
1 1/2	0.8...36	16	85...4100
2	1.3...64	20	130...6400

Note:

The flow ranges specified in the table above have been calculated for each pipe diameter from the known flow velocity range of the KAL. It must be noted that flow in pipes is non-uniform across the pipe cross-section and approaches zero at the pipe wall. This means that, in practice, the depth of installation of the probe, the internal pipe diameter, and the flow profile of the liquid in the pipe can interact to produce significant deviations from the flow ranges in this data sheet.

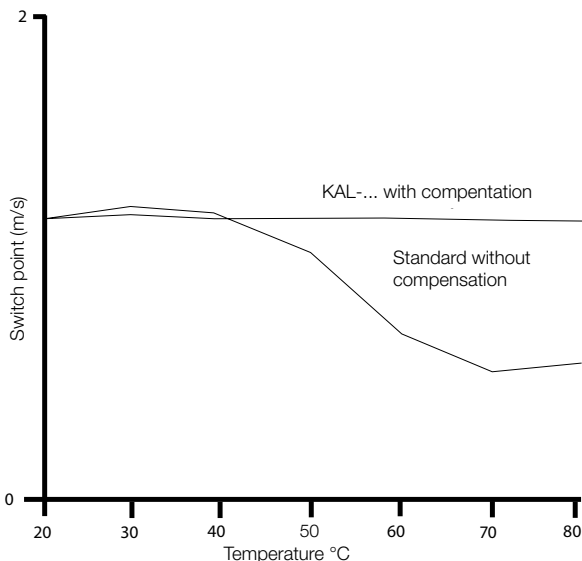



Specifications

Sensor

- Material**
- T-Piece Housing:** 304 SS or Brass
- Probe:** 304 SS or 316 SS
(Depending on Model Code)
- Cable:** PVC Clad, Silicone Optional
- Cable Gland:** Ni-plated Brass
- Cable**
- Length:** 6 feet (Max. 330 feet)
- Conductors:** 2x20 AWG
- Media:** Water-Based Liquids
- Switching Range**
- Water:** 0.2 to 6.6 ft/s
- Operating Conditions**
- Temperature:** 0...176 °F
- Option “..HT“:** 32...250 °F
- Pressure:** (1450 PSIG Maximum
360 PSIG for Models
KAL-5132 & 5140)
- Protection:** IP 68
- Accuracy**
- Display:** ± 10%
- Temperature:** ± 2%
- Repeatability:** ± 2%
- Response Time:** 5...12 seconds (typically)

Controller

- Power:** 3.6 W Max. at 24 V_{DC}
or 24/110/230 V_{AC}
- Relay:** Fail-safe SPDT
3 A at 250 V_{AC} Max.
- Status Indicator:** LED for Relay & Power
- Adjustments:** For Type of Liquid and
Switch Point Via Potentiometer
- Ambient Temperature Range:** 0...176 °F
- Protection**
- Case:** IP 40
- Terminals:** IP 20
- Housing:** Polycarbonate
- LxWxD:** 2.95" x 2.17" x 4.33"
- Fail Safe Features**
- Power Loss:** 10 Year Memory
Retention
- Switch:** Relay Energizes
During Normal
Operation
- Cable Break:** Alarm State Signaled
- Rail Mounting:** DIN EN 50022 and
DIN 46277

Dimensions

KAL-6000

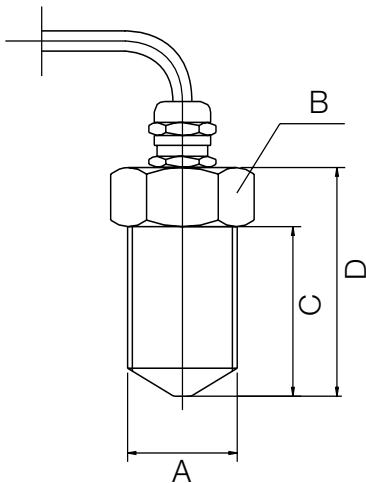

A (NPT)	B (Hex)	C	D
1/4"	19 mm	1.0"	1.7"
1/2"	27 mm	1.7"	2.3"
3/4"	32 mm	1.7"	2.3"

KAL-5000

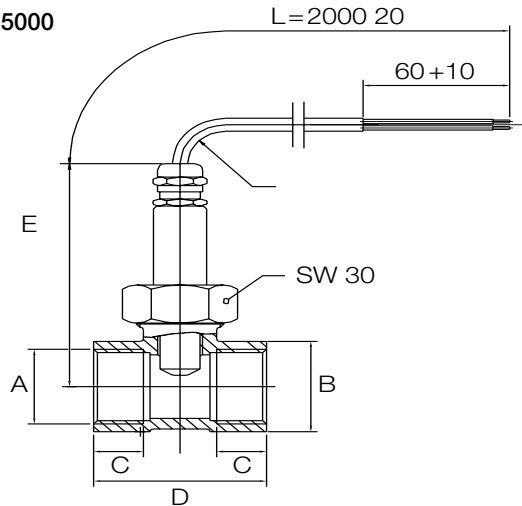

A (NPT)	B (Hex)	C	D	E
1/4"	27 mm	0.4"	2.0"	3.2"
3/8"	27 mm	0.4"	2.0"	3.2"
1/2"	27 mm	0.4"	2.0"	3.2"
3/4"	32 mm	0.6"	2.1"	3.3"
1"	36 mm	0.6"	2.2"	3.4"
1 1/4"	46 mm	0.6"	2.0"	3.6"
1 1/2"	55 mm	0.6"	2.0"	3.7"



Thermal Flow Switch Model KAL

Selecting a System

The electronic flow switch consists of:

- the controller
- the sensor

The connecting cable between the two parts may be up to 330 feet long. With the KAL-E300 series units, temperature correction is required with cable lengths over 33 feet.

Controllers

Three units are available. Each is compatible with the full series of sensors. Electronic circuitry is located in a standard DIN housing for quick installation on terminal rails.

• KAL-E100 Series

The KAL-E100 is equipped with a flow rate sensitive, isolated SPDT relay. The relay status is indicated by means of a green LED.

• KAL-E200 Series

Same as the KAL-E100, but with a trend indicator for flow rate and switch point.

• KAL-E300 Series

Same as KAL-E200 but with a temperature switch. In addition to monitoring the flow, this model can be used to monitor the temperature. The specified alarm temperature can be from 0 to 176 °F.

SPDT relays are activated if the flow drops below the specified flow velocity, or if the temperature drops below the specified temperature.

Sensors

All of the sensor models can be used with any of the three controllers.

Selection is a function of:

- Connector threads
- Max. operating pressure 1450 PSIG
- Max. media temperature 176 °F (250 °F Optional)
- Sensor wetted parts

Order Details for Probe with Integral T-Piece (Example: KAL-5240 HT)

Fitting (NPT)	Probe Material	Order Number		Option
		Housing Material		
		Brass	304 SS	Suffix "..HT"
1/4"	304 SS	KAL-5105	KAL-5205	High Temperature Sensor, 32...250 °F
3/8"	304 SS	KAL-5110	KAL-5210	
1/2"	304 SS	KAL-5115	KAL-5215	
3/4"	304 SS	KAL-5120	KAL-5220	
1"	304 SS	KAL-5125	KAL-5225	
1-1/4"	304 SS	KAL-5132	KAL-5232	
1-1/2"	304 SS	KAL-5140	KAL-5240	



Order Details for Insertion Style Probe (Example: KAL-6305 HT)

Fitting	Order Number		Option
	Probe Material		
	304 SS	316 SS	Suffix "..HT"
1/4" NPT	KAL-6205	KAL-6305	High Temperature Sensor, 32...250 °F
1/2" NPT	KAL-6215	KAL-6315	
3/4" NPT	KAL-6220	KAL-6320	
M 12x1	KAL-6212	-	

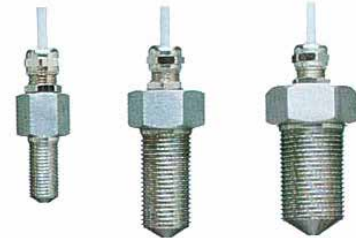

Order Details for Controller (Example: KAL-E310 HT)

Description	Supply Voltage	Order Number	Option
			Suffix "..HT"
1 Flow Rate Output	230 V _{AC} (± 10%)	KAL-E100	High Temperature Controller, 32...250 °F
	110 V _{AC} (± 10%)	KAL-E110	
	24 V _{AC} (± 10%)	KAL-E120	
	24 V _{DC} (+ 15%–10%)	KAL-E130	
1 Flow Rate Output with Trend Indicator	230 V _{AC} (± 10%)	KAL-E200	
	110 V _{AC} (± 10%)	KAL-E210	
	24 V _{AC} (± 10%)	KAL-E220	
	24 V _{DC} (+ 15%–10%)	KAL-E230	
1 Flow Rate Output with Trend Indicator, 1 Temperature Relay Output	230 V _{AC} (± 10%)	KAL-E300	
	110 V _{AC} (± 10%)	KAL-E310	
	24 V _{AC} (± 10%)	KAL-E320	
	24 V _{DC} (+ 15%–10%)	KAL-E330	

