

Positive Displacement Flowmeters

for Clean, Corrosive Chemicals



measuring
•
monitoring
•
analyzing

DOC



- Measuring Ranges:
0.13...26 GPH, 4.0...132 GPH, &
0.8...21 GPM
- Viscosity Range: Up to 1000 cP
- Accuracy: $\pm 0.5\%$ of Reading
- Body & Gear Material: PPS
- p_{\max} : 75 PSI or 145 PSI
- t_{\max} : 176 °F
- Reed Switch or Hall-Effect Output



KOBOLD companies worldwide:

ARGENTINA, AUSTRALIA, AUSTRIA, BELGIUM, BULGARIA, CANADA, CHILE, CHINA, COLOMBIA, CZECH REPUBLIC, EGYPT, FRANCE, GERMANY, HUNGARY, INDIA, INDONESIA, ITALY, MALAYSIA, MEXICO, NETHERLANDS, PERU, POLAND, REPUBLIC OF KOREA, ROMANIA, SINGAPORE, SPAIN, SWITZERLAND, TAIWAN, THAILAND, TUNISIA, TURKEY, UNITED KINGDOM, USA, VIETNAM

KOBOLD Instruments, Inc.
1801 Parkway View Drive
Pittsburgh, PA 15205
Main Office:
1.800.998.1020
1.412.788.4890
info@koboldusa.com
www.koboldusa.com



Description

Oval Wheel Flowmeters are positive displacement flowmeters where the passage of liquid causes two oval gears to rotate within a precision measuring chamber and with each rotation a fixed volume of liquid passes through the meter. Magnets embedded within the gears initiate a high resolution pulse train output. The pulse output can be wired directly to process control and monitoring equipment or can be used as an input to instruments supplied with or fitted directly onto the meter. The flowmeter is available as a blind transmitter with a pulse output capable of interfacing to most monitoring and control instrumentation or the meter can be fitted with reed switch.

This technology allows precise flow measurement and dispensing of most clean liquids regardless of their conductivity, with other liquid characteristics having no or minimal effect on meter performance. This metering technology does not require flow profile conditioning or straightline runs as required with alternative flow technologies, making the installation relatively compact and low cost.

Operation:

Liquid travels around the crescent shaped chambers created by the rotational movement of the rotors

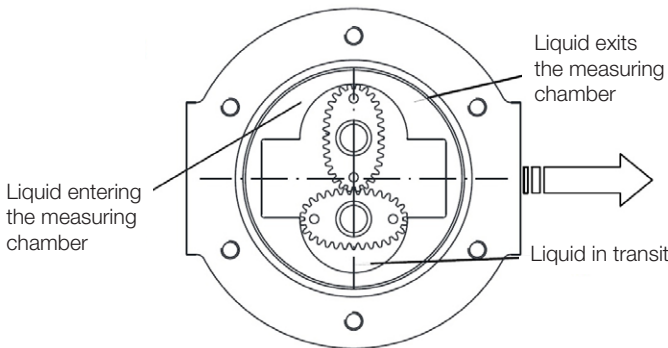

Positive displacement flowmeters are an inexpensive means to accurately meter many high viscosity liquids as high as one thousand centipoise. The appropriate meter must be sized to accommodate the pressure drop across the primary measuring elements (oval rotors) and to not exceed the maximum pressure drop of the meter. The flowmeter should be installed so that the rotor shafts are in the horizontal plane.

Areas of Application

For all Clean Liquids Like:

- Non-Aromatic/Non-Halogenated Chemicals
- Additives
- Water Based Liquids
- Diesel Exhaust Fluid (DEF or AdBlue)
- Most Fuels
- Fuels and Lubricating Oils



Technical Details

Materials

Body/Cap:	PPS
Oval Gears:	PPS
Axles (Shafts):	Hastelloy® C
O-rings:	FFKM (DOC-51..) FEP-O-seal/PTFE Encapsulated (DOC-52..)

Accuracy: ± 0.5% of Reading

Repeatability: Typ. ±0.03%

Protection: IP67

Media Temp.: -40 °F ... 176 °F
(-40 °C ... 80 °C)

Max. Ambient Temp.: 140 °F

Max. Pressure: 75 PSI (DOC-51..)
145 PSI (DOC-52..)

Electrical Connection

1/4" Models: M12x1 (Micro -DC) or 3 ft. Jacketed Cable

1" Models: Terminal block via 1/2" NPT or M16x1.5 Female

Recommended Filter

DOC-51..:	<75 µm micron (200 mesh)
DOC-52..:	<250 µm micron (60 mesh)

Pulse Output

Reed Switch Pulse Output (..R0)

The reed switch output is a 2-wire normally open SPST voltage free contact ideal for installations without power.

Hall Sensor Pulse Output (..H0)

In the electronic option H0, a Hall Effect sensor is combined with a reed switch output. The electrical connection is provided in 3-wire version. The output is actively switched either to +Vs or to ground. The external supply voltage is 4.5 ... 24 V_{DC}. A pull up resistor is required. The high signal is approximately equal to the supply voltage +Vs and the low signal is approximately 0 V. The electrical load may optionally be connected to the supply voltage or to GND.



Output Signals	Standard Pulse Meter		2x Digital (Square Wave)
Reed Switch ¹⁾ (Mechanical Sensor)	Current	max.	500 mA
	Voltage	max.	30V _{DC}
	Contact Rating	max. ²⁾	10 W
Hall Effect ¹⁾ (Electronic Sensor)	Maximum Current		7.5 mA
	Operating Voltage		4.5 V ... 24 V _{DC}
	Transistor Type		Open-Collector NPN

¹⁾ Voltage and current specifications apply per sensor (not combined)

²⁾ Contact rating maximum is 10 W. Neither current nor voltage maximums should be exceeded in achieving this

Pressure Drop*

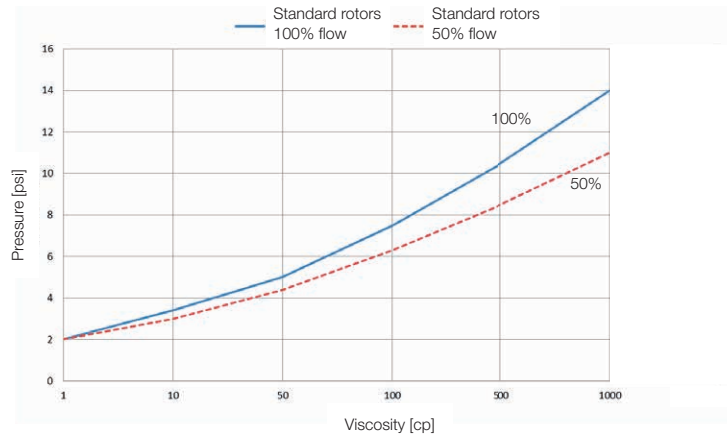

*The curve above represents the pressure drop for standard oval rotors at various viscosities.

Output Pulse Resolution

Model	Measuring Range	Pulse/Gallon	Pulse/Liter
DOC-510..	Below 5 cP: 0.5...26 GPH (2.0...100 LPH)	3785	1000
	5 ... 1000 cP: 0.13...26 GPH (0.5...100 LPH)		
DOC-515..	Below 5 cP: 6.7...132 GPH (25.0...500 LPH)	1514	400
	5 ... 1000 cP: 4.0...132 GPH (15.0...500 LPH)		
DOC-520..	Below 5 cP: 2.2...18.4 GPM (80.0...70.0 LPM)	197	52
	5 ... 1000 cP: 0.8...21.0 GPM (3.0...80.0 LPM)		



Positive Displacement Flowmeters Model DOC

Order Details (Example: DOC-5 15G N2 H01)

Model	Material	Range/Scale	Mech. Connection	Output/Electrical Connection
DOC-	..5.. = PPS	..10G.. = 0.13...26 GPH ..15G.. = 4...132 GPH	..N2.. = 1/4" NPT	..H01 = Hall Sensor/Reed Switch, 3 ft. PVC Jacketed Cable w/3" Flying Lead ..H02 = Hall Sensor/Reed Switch, M12x1 (Micro DC)
		..10H.. = 0.5...100 LPH ..15H.. = 15...500 LPH	..R2.. = 1/4 BSP	..R01* = Reed Switch (Dual), 3 ft. PVC Jacketed Cable w/3" Flying Lead ..R02* = Reed Switch (Dual), M12x1 (Micro DC)
		..20G.. = 0.8...21 GPM	..N6.. = 1" NPT	..H03 = Hall Sensor/Reed Switch, Terminal Block via 1/2" NPT ..R03* = Reed Switch (Dual), Terminal Block via 1/2" NPT
		..20H.. = 3...80 LPM	..R6.. = 1 BSP	..H04 = Hall Sensor/Reed Switch, Terminal Block via M16x1.5 ..R04* = Reed Switch (Dual), Terminal Block via M16x1.5

* Should be chosen when using DOC intrinsically safe circuits as "simple apparatus"

Dimensions

DOC-51..

M12x1 (Micro-DC)

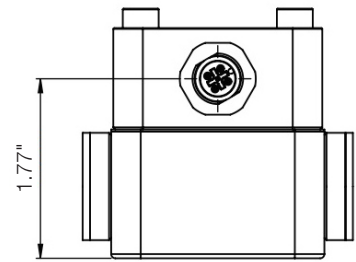
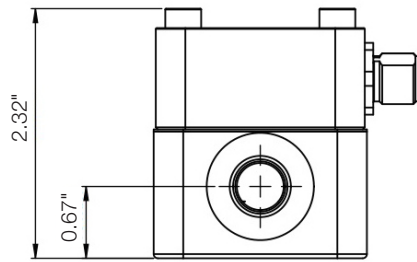
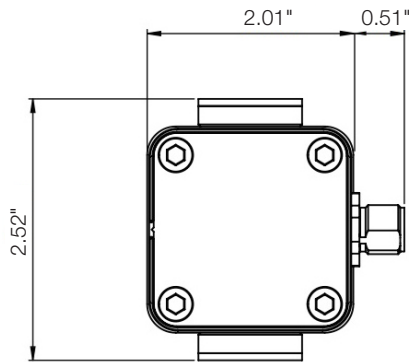

DOC-51..

PVC Jacketed Cable

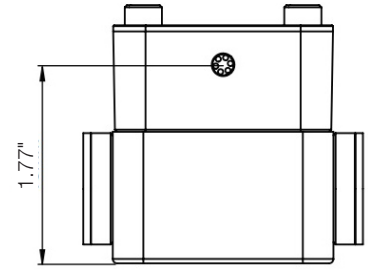
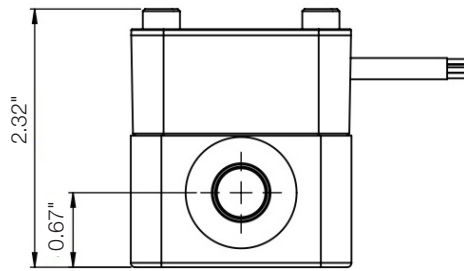
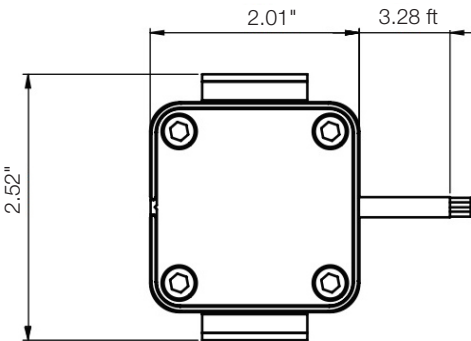

Dimensions Continued

DOC-520..

