

# Veron Quicky Style F6F Hellcat

## Assembly Guide

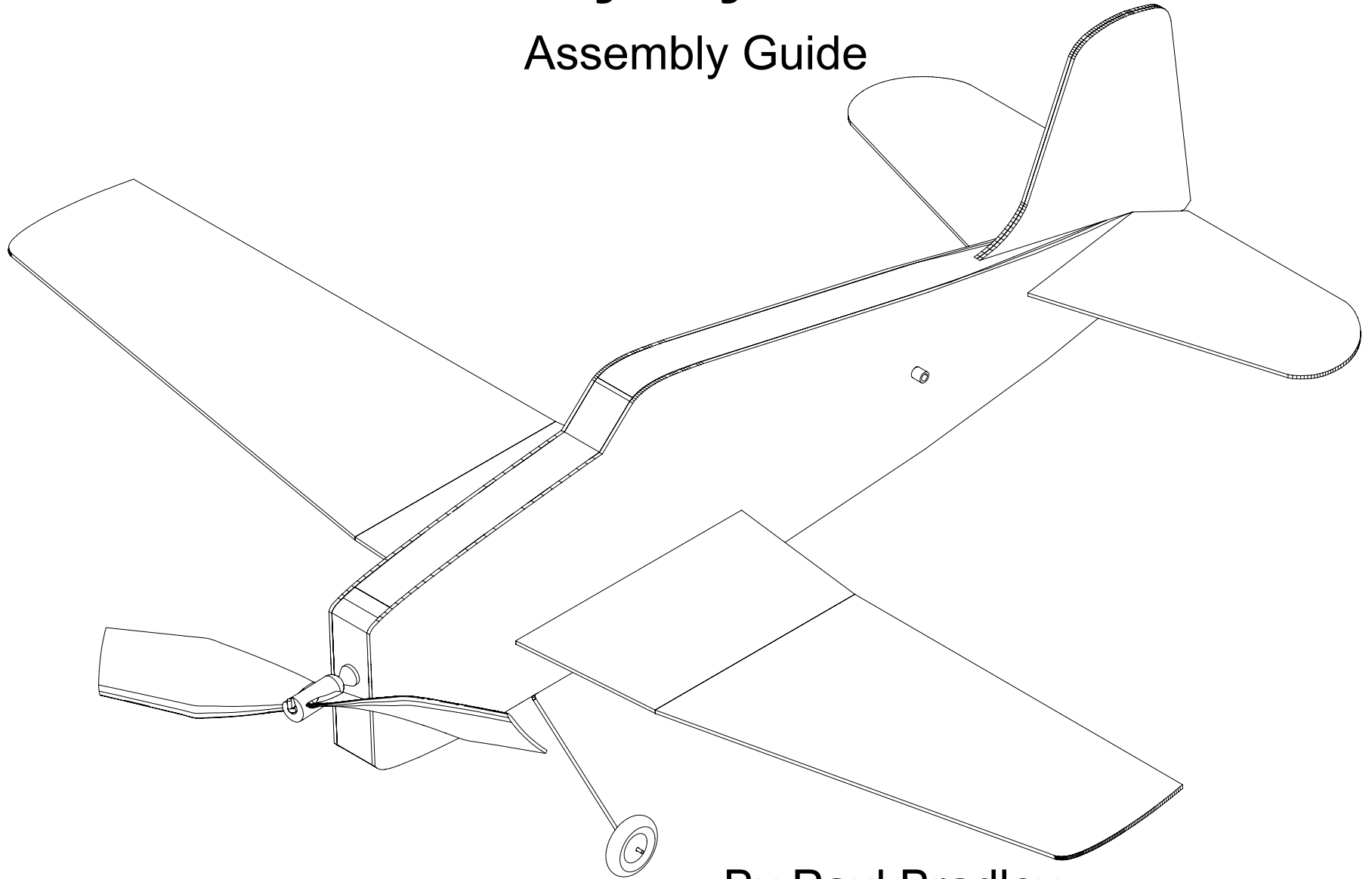

By Paul Bradley  
February 2026

1.

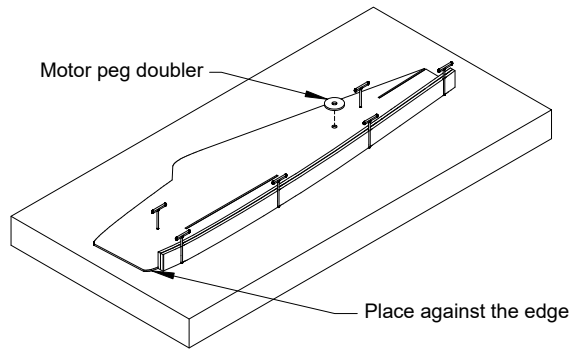

Cut two lengths of 1/16"x3/8" balsa strip stock that are 8 1/8" long. Glue them together with an air dry glue and while the glue is still wet, place them against the bottom edge of a fuselage side as shown. DO NOT GLUE TO THE FUSELAGE SIDE. Also glue a 3/8" motor peg doubler to the fuselage side as shown. Let all glue dry and then remove the strip.

2.

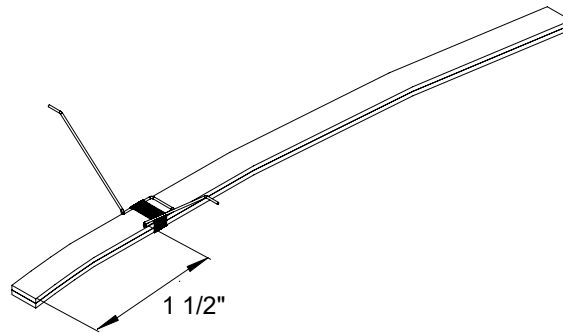

Using the provided pattern, bend the landing gear from .025" piano wire. Bind the landing gear with thread and glue to the bottom edge piece as shown 1 1/2" from the front edge.

3.

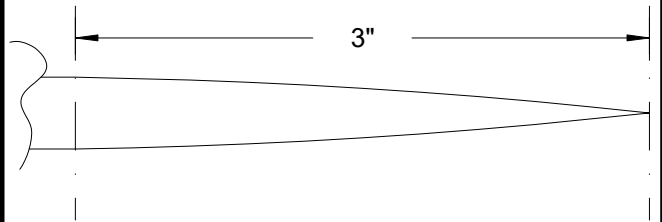

Shape the top rear and bottom fuselage edge pieces using the pattern provided here.

4.

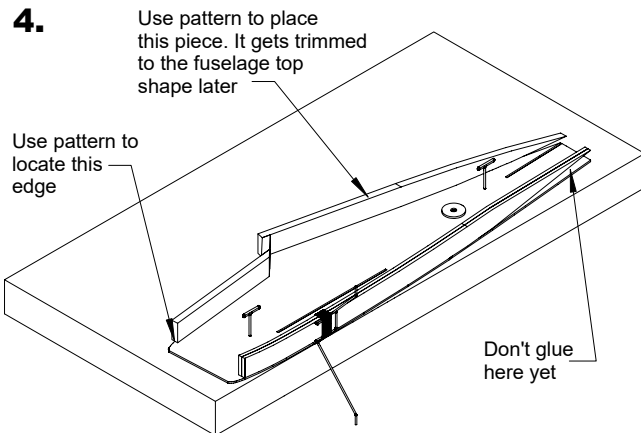

Glue the 3/8" wide fuselage edge pieces to one side of the fuselage as shown.

5.

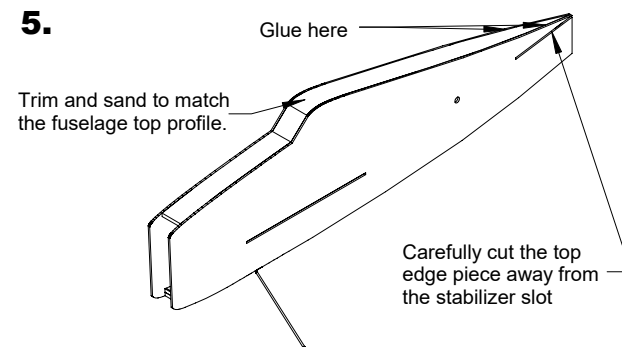

Glue a motor peg doubler to the inside face of the second fuselage side. Glue the other fuselage side to the assembly. When the glue is set pull the sides together at the rear and glue. Once all glue has fully set, shape the top edge piece to match the top contour of the fuselage sides. Also, cut the top edge piece away from the stabilizer slot.

6.

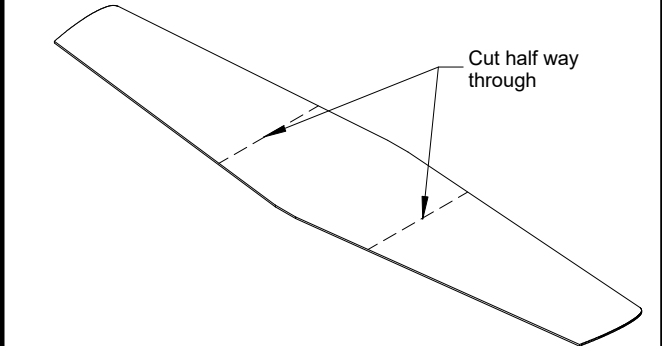

Use the printed lines on the top side of the wing at the dihedral breaks as a location guide and draw pencil lines on the bottom of the wing. Make a cut half way through the wing balsa along the drawn lines.

7.

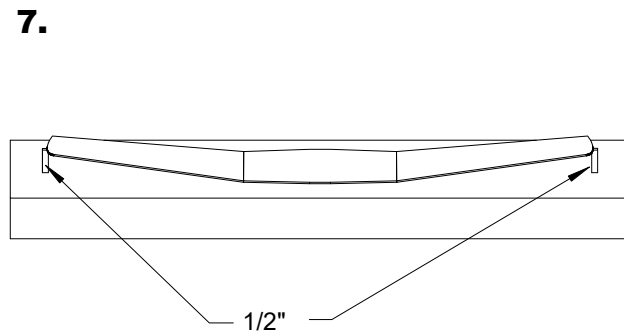

Apply some air dry glue to the bottom of the wing along the cut lines. Pin the wing down to your building board and block up each tip 1/2". Let the glue dry completely before removing the wing from the building board.

8.

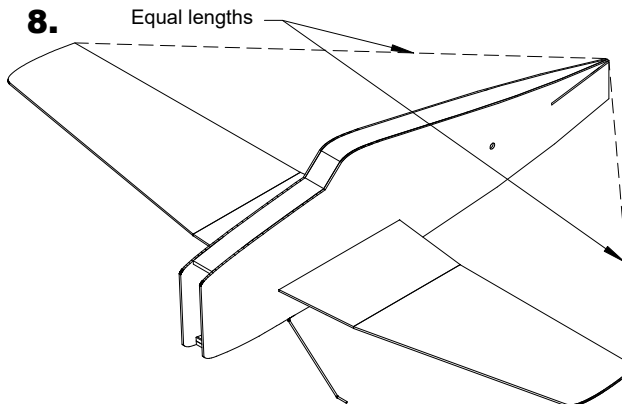

Slide the wing into the fuselage slots. Use the printed dashed lines as alignment guides. Make sure the distances from the forward edge of the wing tips to the nose of the fuselage are equal.

9.

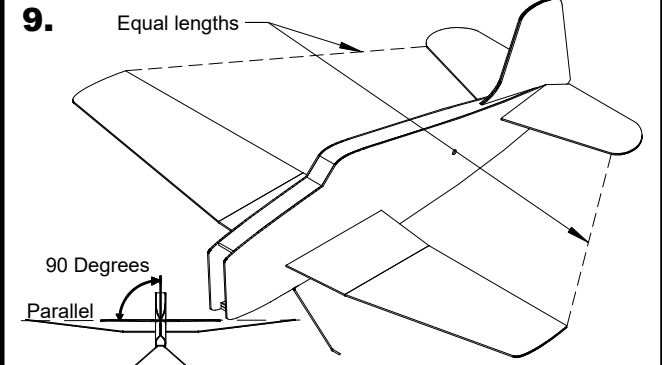

Glue the stab to the fuselage. Make sure the distances from the stab tips to the wing tips are equal. Also make sure the stab is parallel to the wing when viewed from the rear. When the stab glue is set, glue the fin to the assembly. Sight from the rear to make sure the fin is vertical.

10.

Cut a 1/2" long opening centered over the motor peg

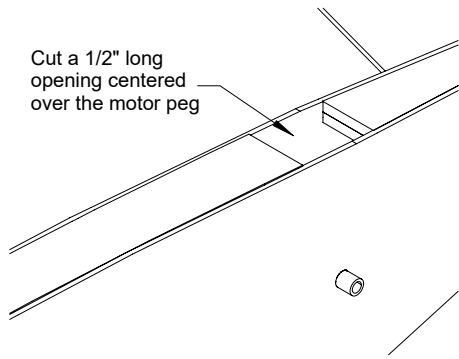

Cut a 5/8" long length of 3/32" aluminum tubing. Insert the piece in the motor peg holes in the fuselage sides. Flip the model over and cut a opening in the bottom 1/8" x 3/8" edging that is 1/2" long. Center the opening on the motor peg.

11.

Drop of glue to retain wheels

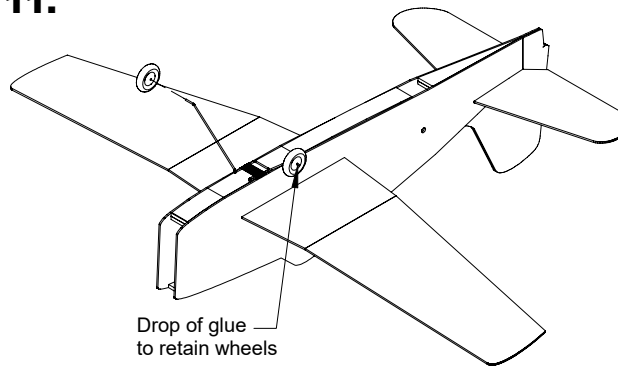

Install 1/2" wheels on the landing gear. A drop of air dry glue on the axle ends can be used to retain the wheels.

12.

1/16" Square Balsa

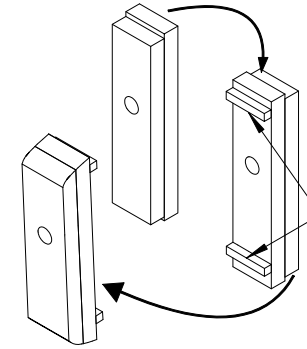

Make up a removable nose block from two pieces of 1/8" x 3/8" strip stock using the provided patterns. Glue the pieces together using the thrust bearing hole for alignment. Place the assembly in the nose of the model and mark the shape of the fuselage sides. Remove the nose block and sand to shape.

13.

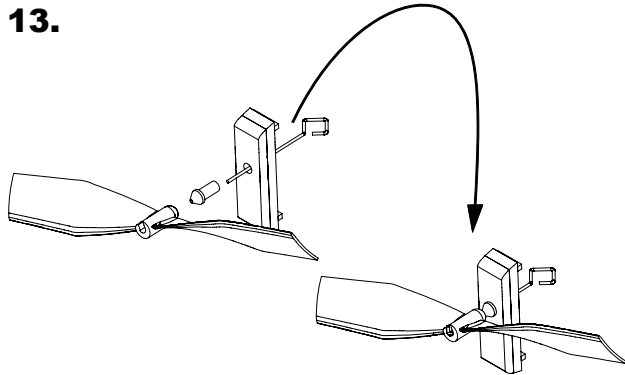

Using something like a Peck thrust bearing for 1/32" prop shafts and the propeller of your choice, complete the nose block assembly. This assembly can be pulled out for stretch winding and loading the rubber motor. (The 3D printed propeller is shown)

14.

1 1/16"

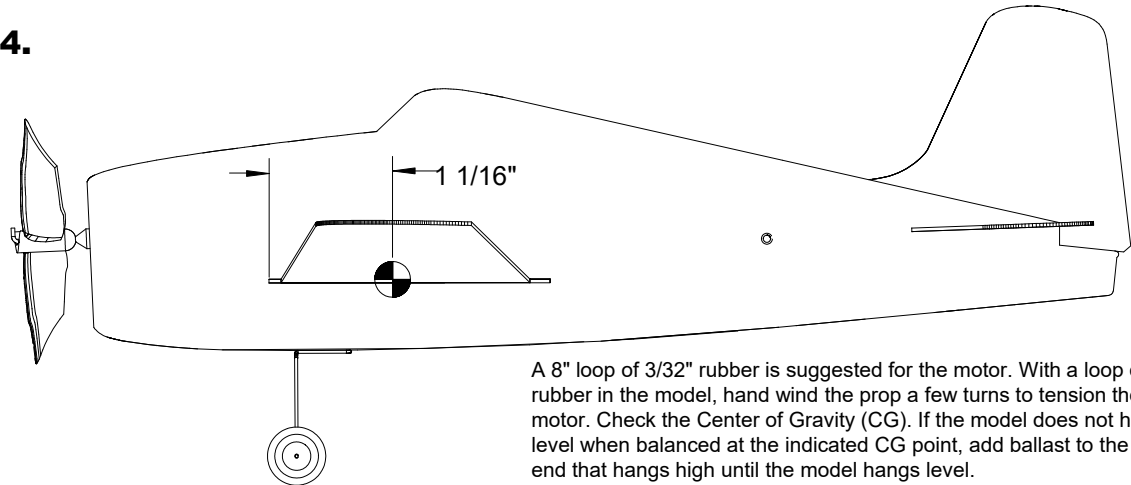

A 8" loop of 3/32" rubber is suggested for the motor. With a loop of rubber in the model, hand wind the prop a few turns to tension the motor. Check the Center of Gravity (CG). If the model does not hang level when balanced at the indicated CG point, add ballast to the end that hangs high until the model hangs level.

Nose Block pieces

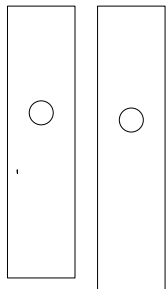

Landing gear pattern make from .025" piano wire

90 Degree bend here



Use this pattern to locate the 1/8" x 3/8" edge pieces